

# AgriMetal

## PARTS LIST

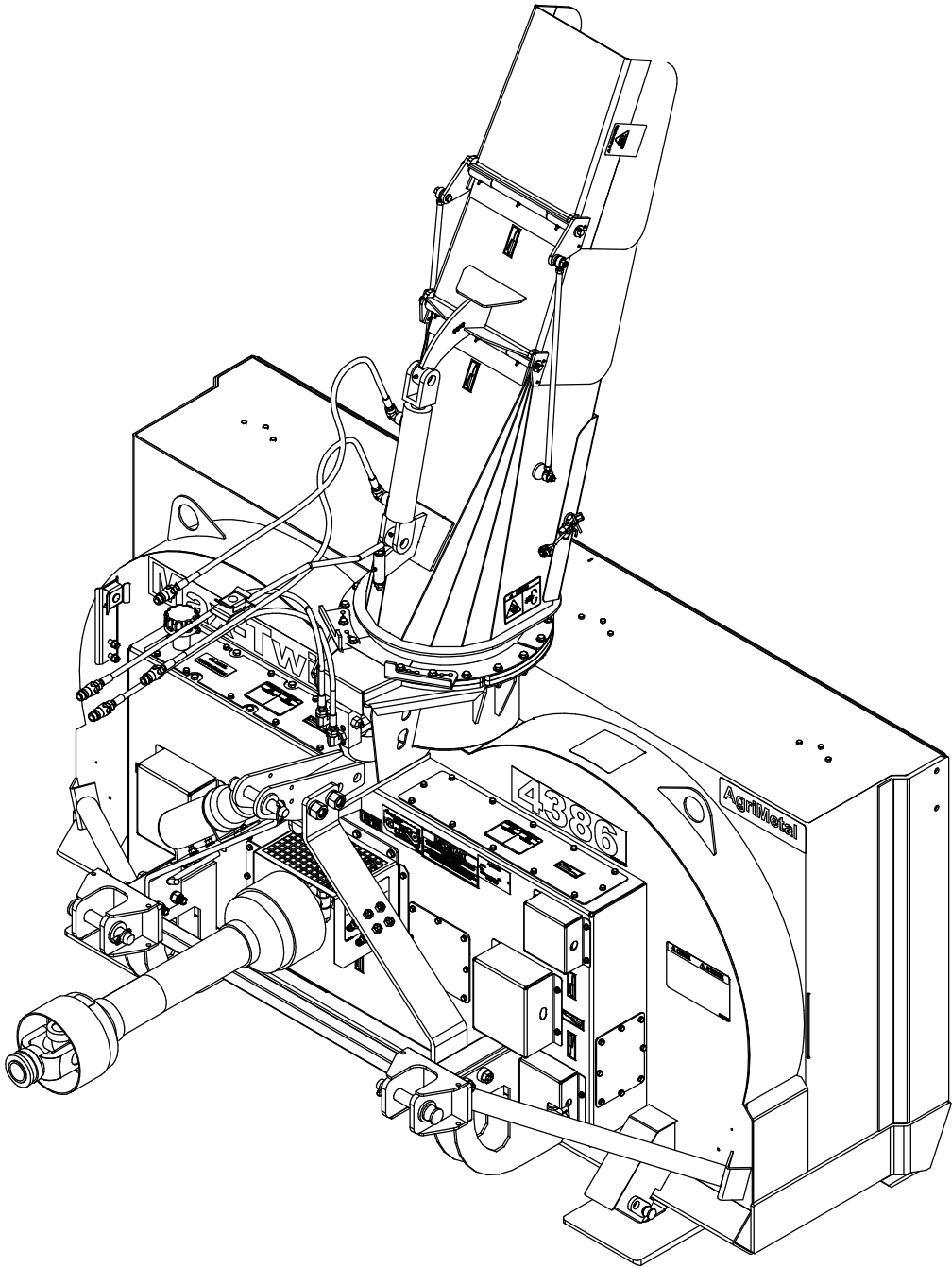

**MTC 4386 (IN OIL)**

#	PART #	Qty	TITLE
1	44-57-0114	1	GEAR BOX DOOR STICKER INCLUDED (RIGHT)
2	49-22-2205	60	WASHER
3	NC01-37-0004	60	HEX. BOLT GR2 ZINC 1/4-28 X 3/4"
4	44-13-0000	1	LEVEL OIL ROD
5	NC13-45-0016	1	FILLING CAP
6	44-57-0117	1	GEAR BOX DOOR STICKER INCLUDED (LEFT)
7	49-01-1500	2	ACCESS DOOR (FRONT & SIDE)
8	44-01-1500	2	ACCESS DOOR (SIDE)
9	44-01-3000	2	BEARING PROTECTOR
10	NC02-41-0013	15	HEX. PEIRCING MET. SCREW 1/4" X 3/4"
11	44-01-3010	1	AUXILAIRY SPROCKET BEARING GUARD
12	44-01-3015	1	AUXILIARY SPROCKET BEARING GUARD
13	48-57-1056	1	PTO GUARD GROUP "STICKER INCLUDED"
14	49-22-1810	4	WASHER

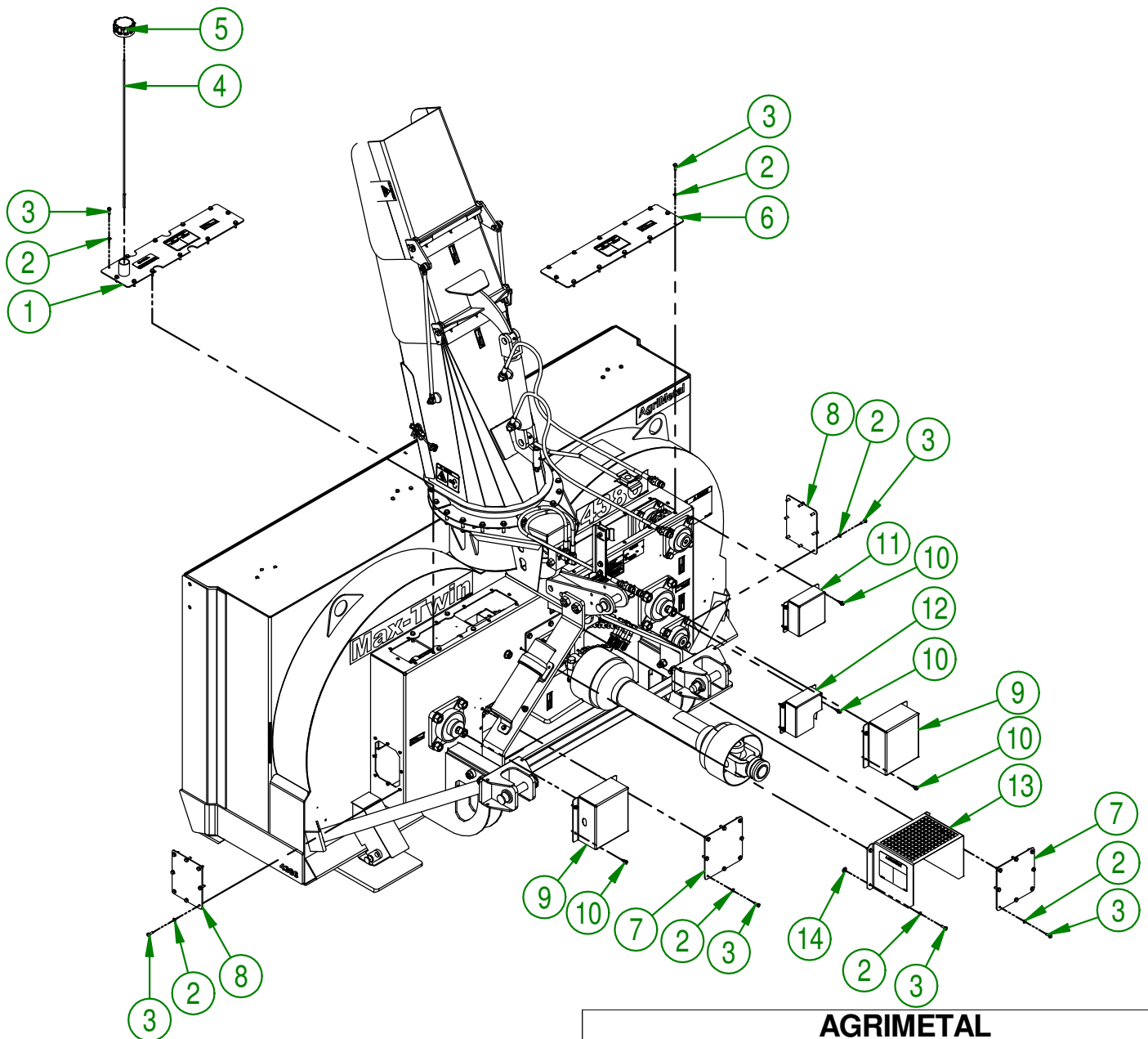

<b>AGRIMETAL</b>	
<b>SNOW BLOWER MAX-TWIN (MTC 4386)</b>	
CREATION : 14/09/18	ASSEMBLY : <b>44-99-0000</b>
REVISION : 22/02/19	AUTHOR : J.KABWE
	Page 1 de 26

#	PART #	Qty	TITLE
1	44-57-0001	1	FRAME STICKER INCLUDED (MTC 4386)
2	44-42-0110	2	BUSHING
3	NC01-78-0017	8	POP RIVET STEEL ROD .187 X .815 CAP. RIV 5/8
4	44-30-9960	4	SAFETY BOLT
5	NC01-94-0013	4	NYLON NUT ZINC 1/2-20"
6	44-50-0605	1	3 POINTS ATTACHMENT HAND (TOP)
7	44-50-0610	2	3 POINTS ATTACHMENT HAND (BOTTOM)
8	NC01-33-0508	2	HEX. BOLT GR8 NC ZINC 7/8-9 X 5" LG
9	NC01-33-0408	4	HEX. BOLT GR8 NC ZINC 5/8-11 X 5"
10	NC02-32-0016	4	LOCK WASHER ZINC 5/8"
11	NC02-32-0018	2	LOCK WASHER 7/8"
12	NC02-07-0022	4	HEX. NUT ZINC 5/8-11
13	NC02-07-0024	2	HEX. NUT NC ZINC 7/8-9
14	48-20-0065	2	3 POINT PIN
15	48-20-0060	1	3 POINT PIN
16	NC01-69-1100	3	LINCH PIN 3/8"
17	NC13-45-0015	2	HEX. CAP 1/2 NPTF MALE

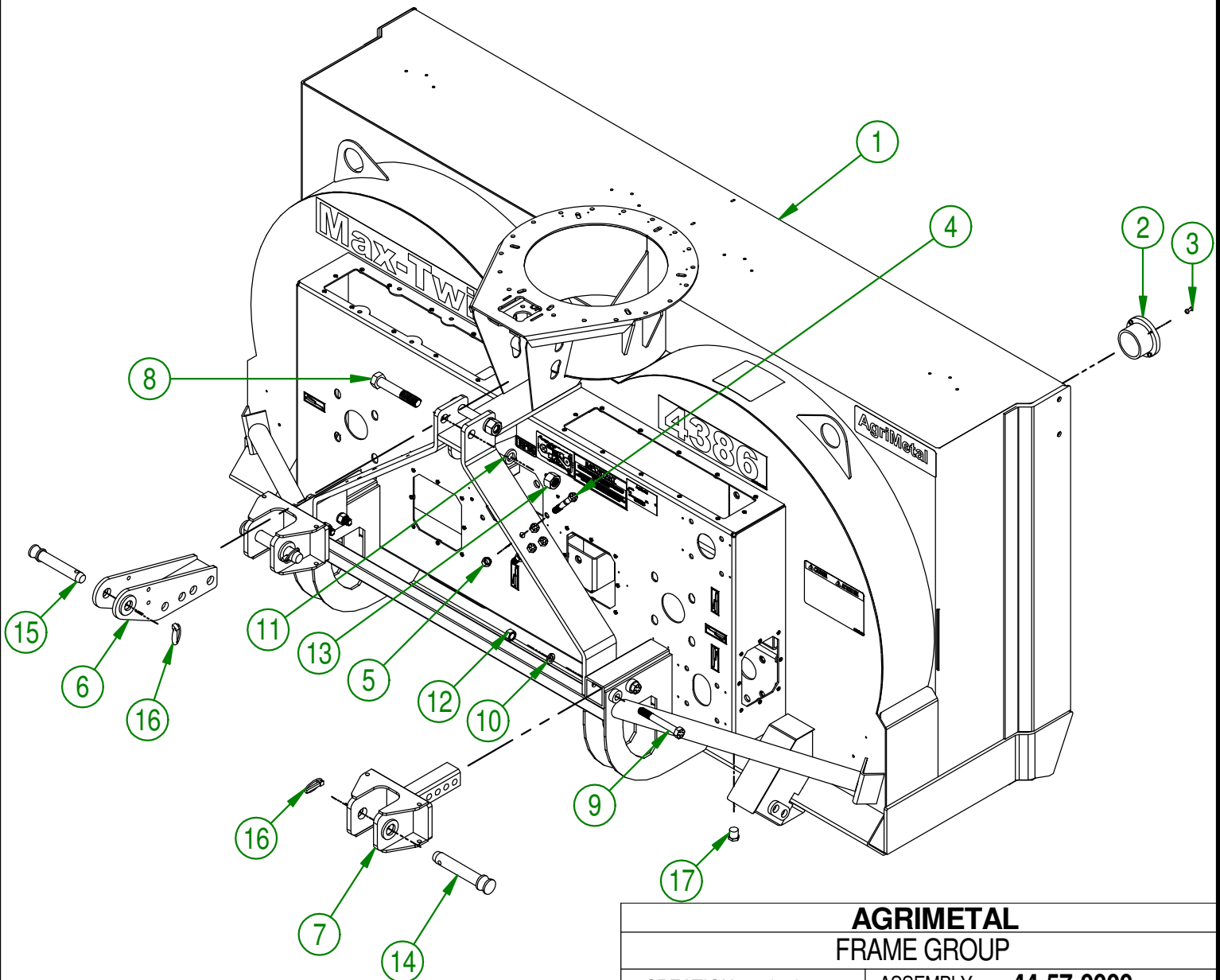

**AGRIMETAL**  
**FRAME GROUP**

CREATION : 11/09/18  
REVISION : 14/12/18

ASSEMBLY : **44-57-0000**

AUTHOR : J.KABWE

Page 2 de 26

#	PART #	Qty	TITLE
1	49-20-0475	1	KNIFE (CENTER)
2	44-20-0465	1	KNIFE (INSIDE RIGHT)
3	44-20-0467	1	KNIFE (INSIDE LEFT)
4	44-20-0460	1	KNIFE (OUTSIDE RIGHT)
5	44-20-0463	1	KNIFE (OUTSIDE LEFT)
6	46-20-0460	1	KNIFE (OUTSIDE RIGHT)
7	46-20-0463	1	KNIFE (OUTSIDE LEFT)
8	NC01-07-0056	54	CARR. BOLT GR5 NC ZINC 5/16-18 X 3/4"
9	NC01-93-0010	54	LOCK NUT ZINC 5/16-18

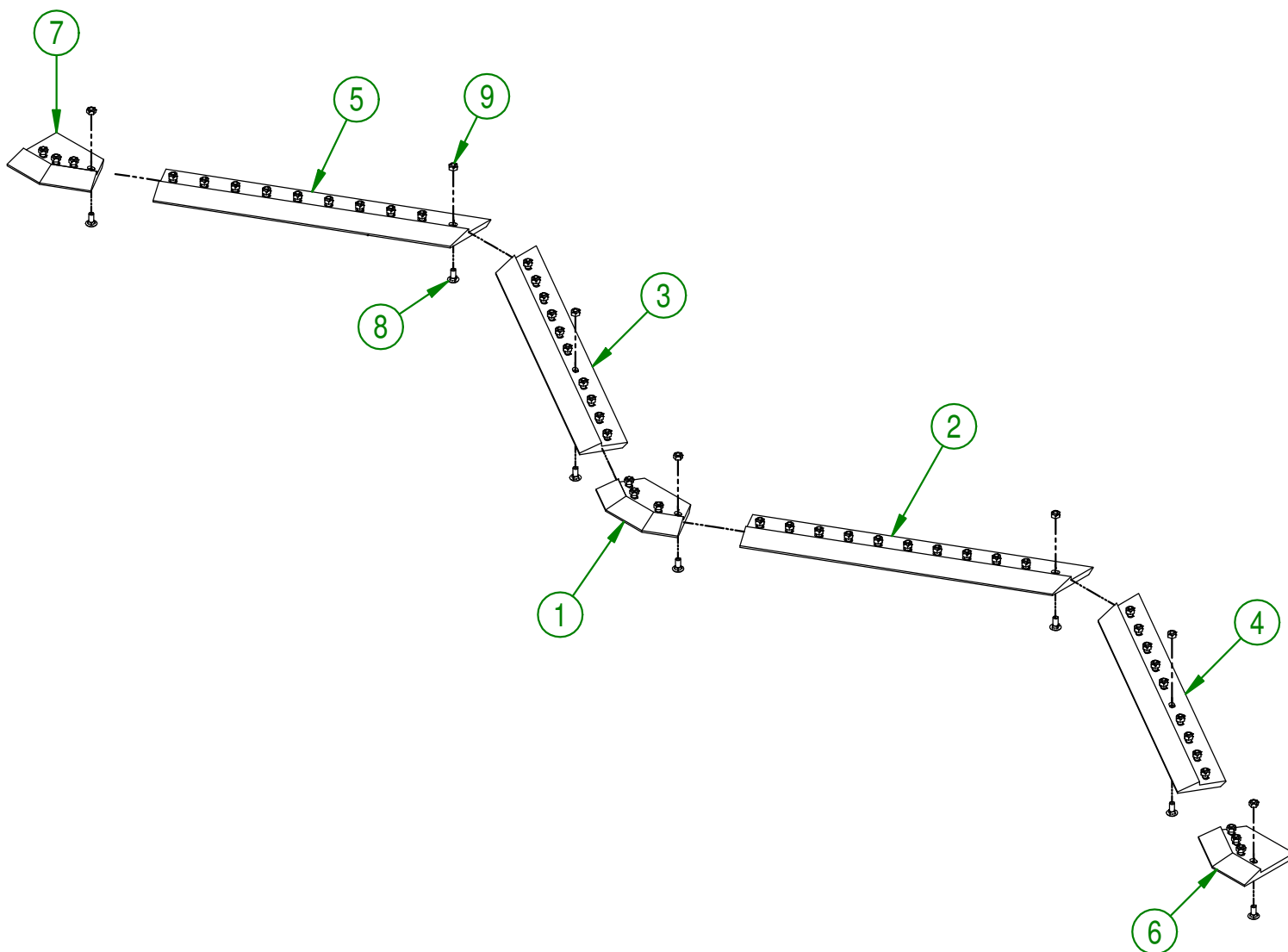

<b>AGRIMETAL</b>	
KNIVES GROUP. (STEEL 450)	
CREATION : 10/09/18	ASSEMBLY : <b>44-57-0220</b>
REVISION : 21/01/19	AUTHOR : J.KABWE      Page 3 de 26

44-57-0005

#	PART #	Qty	TITLE
1	44-55-0005	1	IMPELLER (RIGHT) ASSY.
2	44-50-0545	1	IMPELLER FLANGE
3	44-30-9960	1	SAFETY BOLT
4	NC01-94-0013	1	NYLON NUT ZINC 1/2-20"
5	44-21-0000	1	CLAMPING STOPPER
6	NC02-50-013	1	SOCKET HEAD SCRENS 1/2-13 X 1 1/4"
7	NC02-22-0013	1	WASHER ZINC 5/8 ID X 1 1/2 OD
8	NC02-32-0016	1	LOCK WASHER ZINC 5/8"
9	NC01-29-0394	1	HEX. BOLT GR5 NF ZINC 5/8-18 X 1 1/2"

44-55-0005

#	PART #	Qty	TITLE
10	44-50-0005	1	IMPELLER (RIGHT)
11	NC01-69-0791	1	GREASE FITTING 1/8 NPT STRAIGHT
12	44-38-0200	2	IMPELLER BUSHING

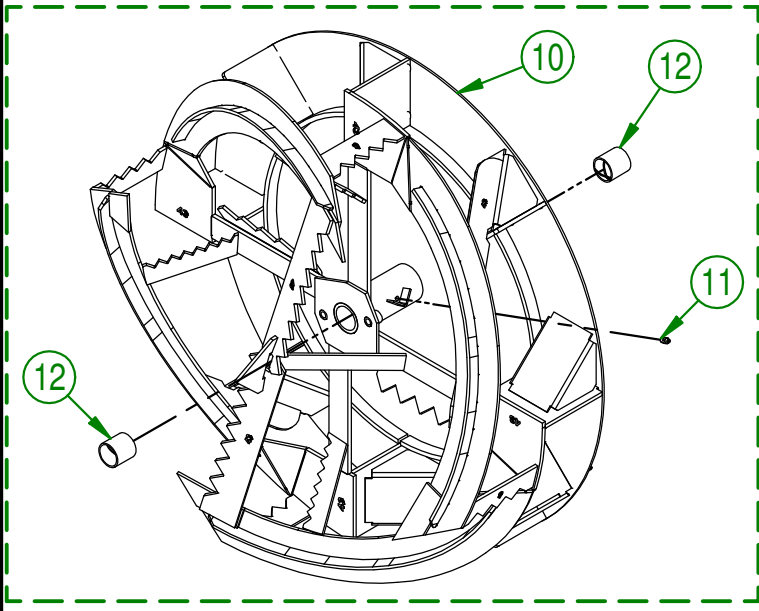
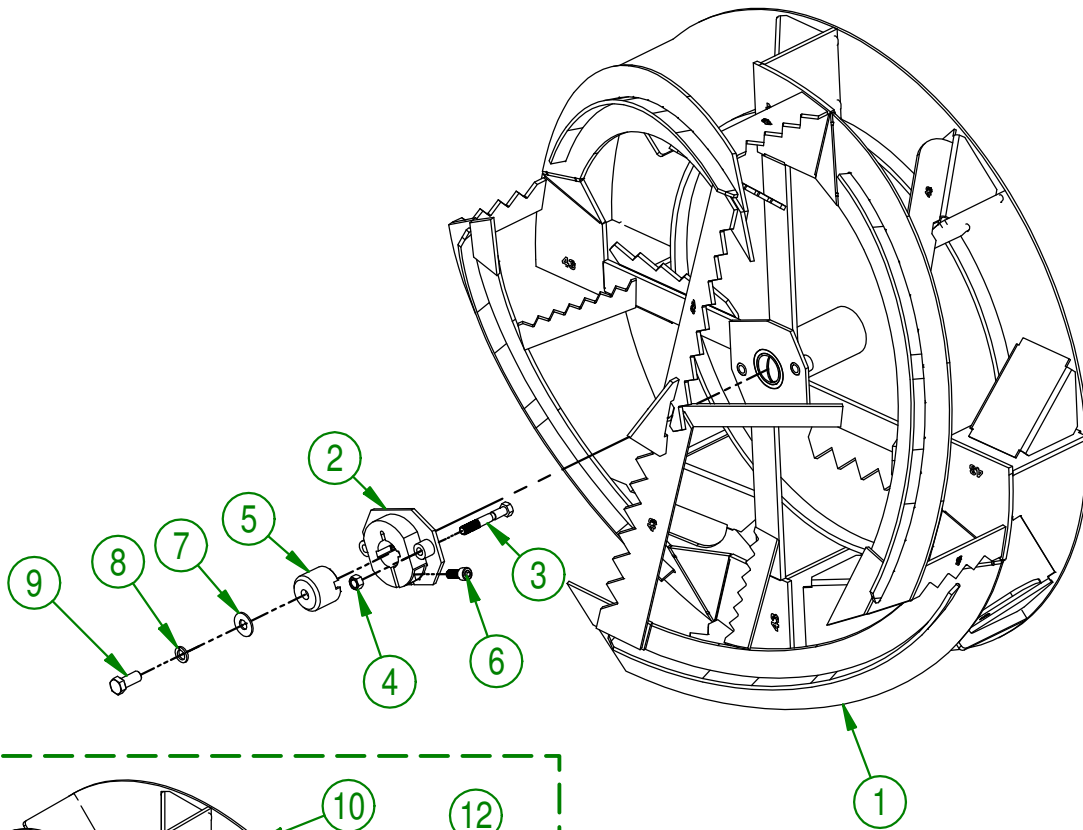

<b>AGRIMETAL</b>	
<b>IMPELLER GROUP (RIGHT)</b>	
CREATION : 11/09/18	ASSEMBLY : <b>44-57-0005</b>
REVISION : 11/09/18	AUTHOR : J.KABWE   Page 4 de 26

44-57-0006

#	PART #	Qty	TITLE
1	44-55-0006	1	IMPELLER (LEFT) ASSY.
2	44-50-0545	1	IMPELLER FLANGE
3	44-30-9960	1	SAFETY BOLT
4	NC01-94-0013	1	NYLON NUT ZINC 1/2-20"
5	44-21-0000	1	CLAMPING STOPPER
6	NC02-50-013	1	SOCKET HEAD SCRENS 1/2-13 X 1 1/4"
7	NC02-22-0013	1	WASHER ZINC 5/8 ID X 1 1/2 OD
8	NC02-32-0016	1	LOCK WASHER ZINC 5/8"
9	NC01-29-0394	1	HEX. BOLT GR5 NF ZINC 5/8-18 X 1 1/2"

44-55-0006

#	PART #	Qty	TITLE
10	44-50-0006	1	IMPELLER (LEFT)
11	44-38-0200	2	IMPELLER BUSHING
12	NC01-69-0791	1	GREASE FITTING 1/8 NPT STRAIGHT

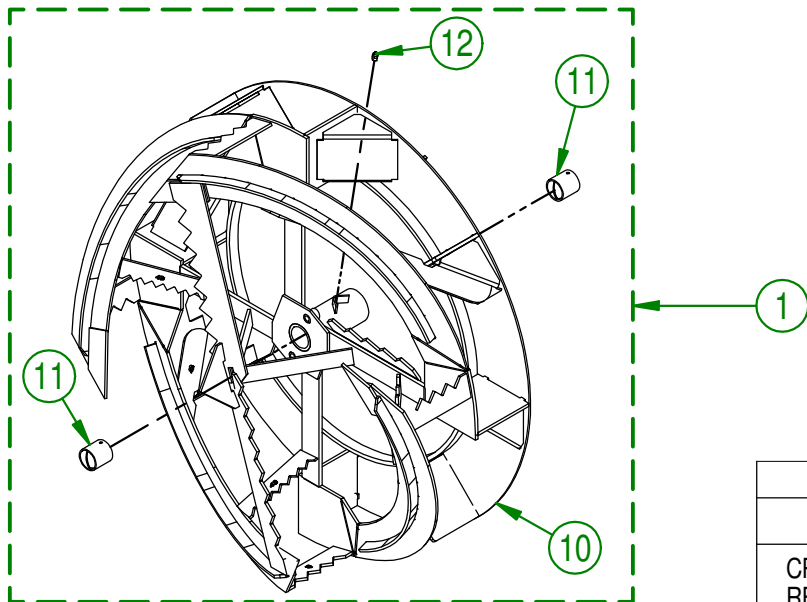
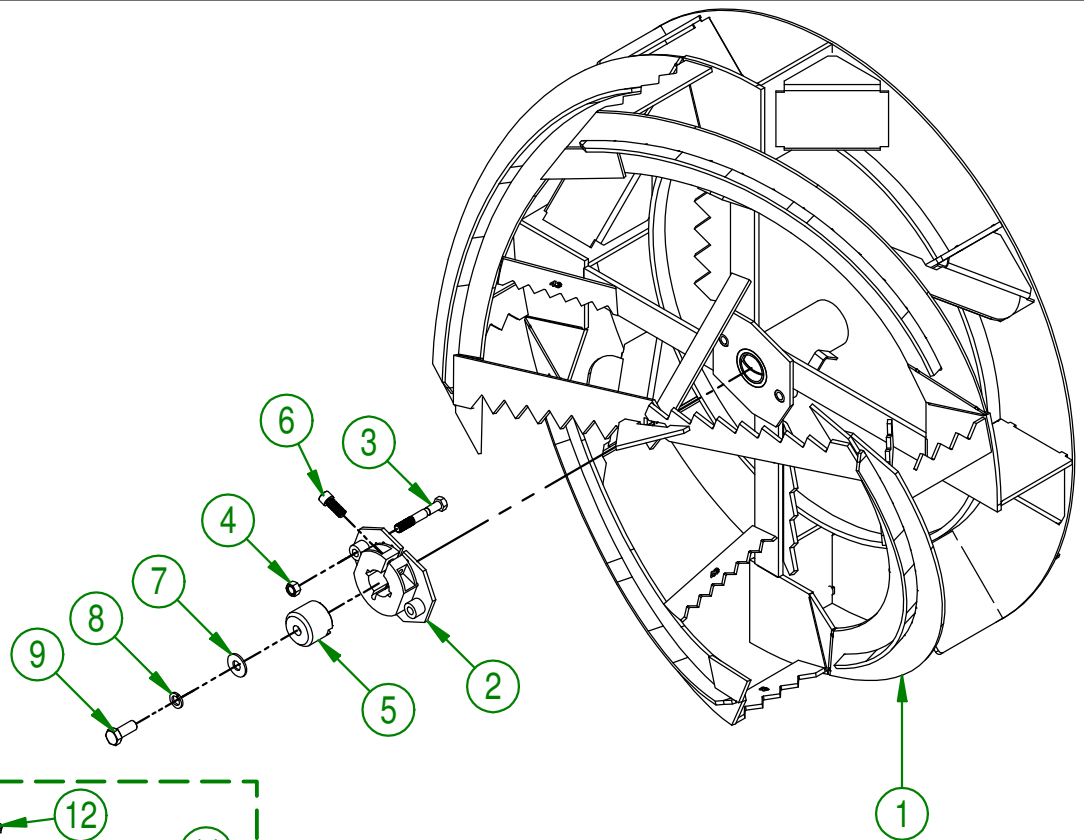

<b>AGRIMETAL</b>	
<b>IMPELLER GROUP (LEFT)</b>	
CREATION : 11/09/18	ASSEMBLY : <b>44-57-0006</b>
REVISION : 11/09/18	AUTHOR : J.KABWE <span style="float: right;">Page 5 de 26</span>

44-57-0090

#	PART #	Qty	TITLE
1	44-55-0090	1	SNOW GUARD (OUTSIDE RIGHT) ASSY.
2	NC01-37-0004	3	HEX. BOLT GR2 ZINC 1/4-28 X 3/4"
3	NC01-97-0004	3	NYLON-INSERT LOCKNUT ZINC 1/4-28

44-55-0090

#	PART #	Qty	TITLE
4	44-57-0094	1	SNOW GUARD (OUTSIDE RIGHT) STICKER INCLUDED
5	46-50-0095	1	SNOW GUARD SUPPORT
6	NC01-17-0068	2	HEX. BOLT GR2 NC ZINC 5/16-18 X 3"
7	NC01-96-0010	2	NYLON NUT HEX. ZINC 5/16-18

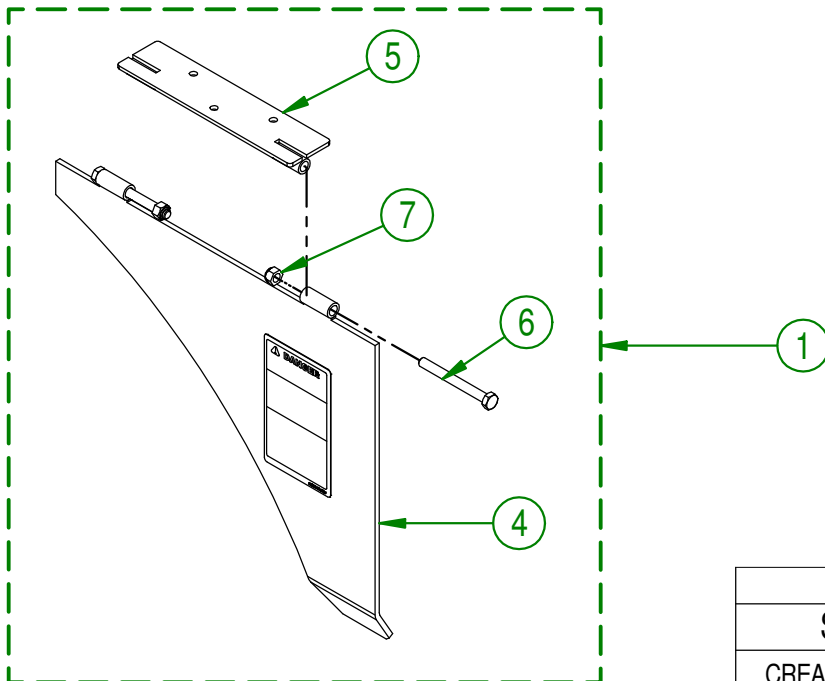
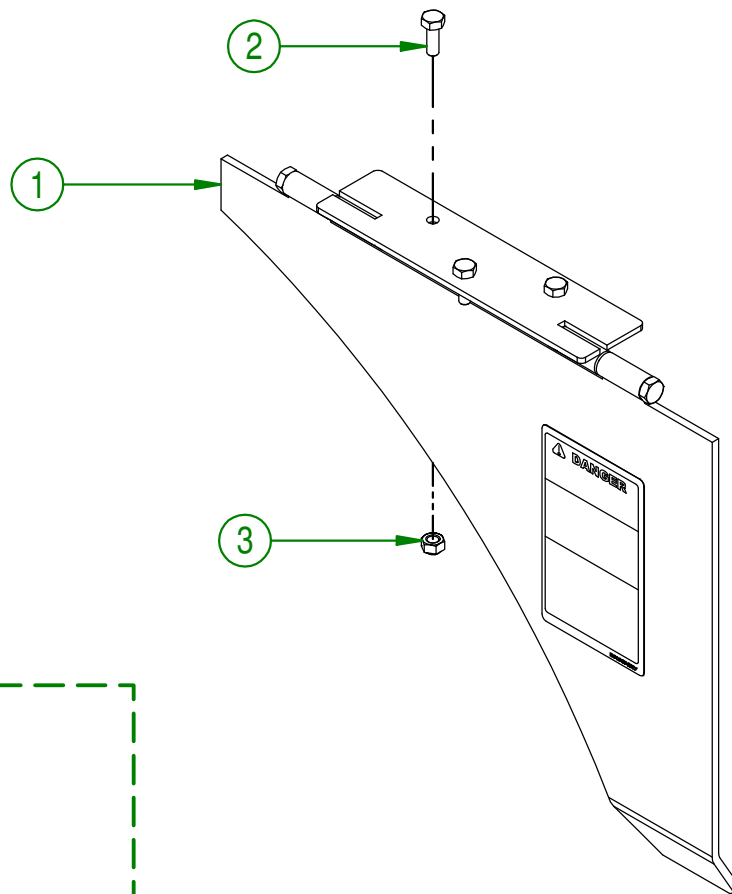

<b>AGRIMETAL</b>	
SNOW GUARD (OUTSIDE RIGHT) GROUP.	
CREATION : 11/09/18	ASSEMBLY : <b>44-57-0090</b>
REVISION : 11/09/18	AUTHOR : J.KABWE   Page 6 de 26

44-57-0091

#	PART #	Qty	TITLE
1	44-55-0091	1	SNOW GUARD (OUTSIDE LEFT) ASSY.
2	NC01-37-0004	3	HEX. BOLT GR2 ZINC 1/4-28 X 3/4"
3	NC01-97-0004	3	NYLON-INSERT LOCKNUT ZINC 1/4-28

44-55-0091

#	PART #	Qty	TITLE
4	44-57-0095	1	SNOW GUARD (OUTSIDE LEFT) STICKER INCLUDED
5	46-50-0095	1	SNOW GUARD SUPPORT
6	NC01-17-0068	2	HEX. BOLT GR2 NC ZINC 5/16-18 X 3"
7	NC01-96-0010	2	NYLON NUT HEX. ZINC 5/16-18

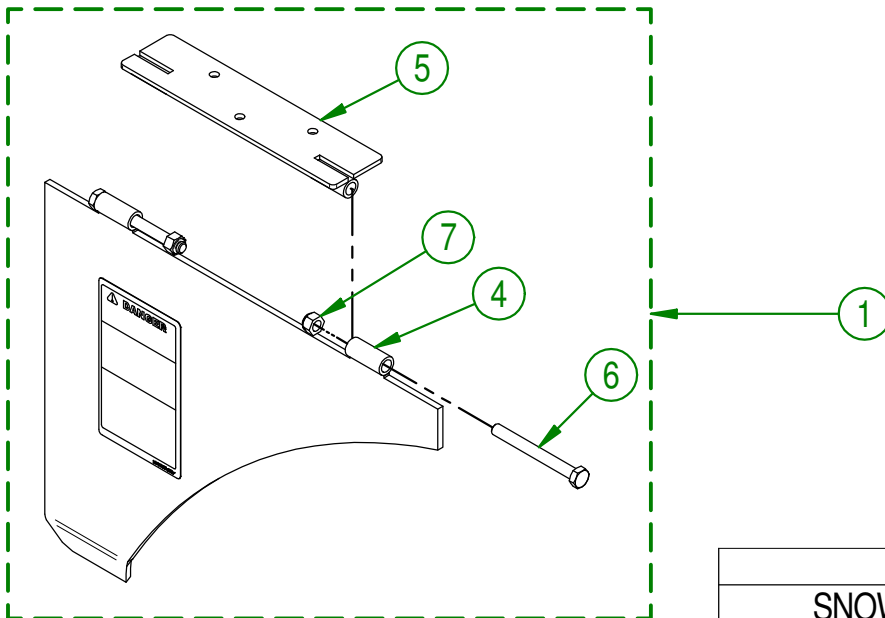
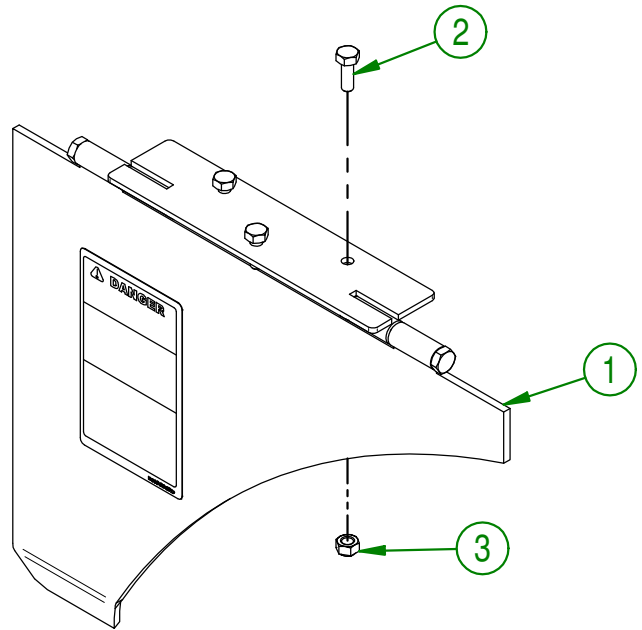

<b>AGRIMETAL</b>	
<b>SNOW GUARD (OUTSIDE LEFT) GROUP.</b>	
CREATION : 11/09/18	ASSEMBLY : <b>44-57-0091</b>
REVISION : 11/09/18	AUTHOR : J.KABWE   Page 7 de 26

44-57-0092

#	PART #	Qty	TITLE
1	44-55-0092	1	SNOW GUARD (INSIDE RIGHT) ASSY.
2	NC01-37-0004	3	HEX. BOLT GR2 ZINC 1/4-28 X 3/4"
3	NC01-97-0004	3	NYLON-INSERT LOCKNUT ZINC 1/4-28

44-55-0092

#	PART #	Qty	TITLE
4	44-57-0096	1	SNOW GUARD (INSIDE RIGHT) STICKER INCLUDED
5	46-50-0095	1	SNOW GUARD SUPPORT
6	NC01-17-0068	2	HEX. BOLT GR2 NC ZINC 5/16-18 X 3"
7	NC01-96-0010	2	NYLON NUT HEX. ZINC 5/16-18

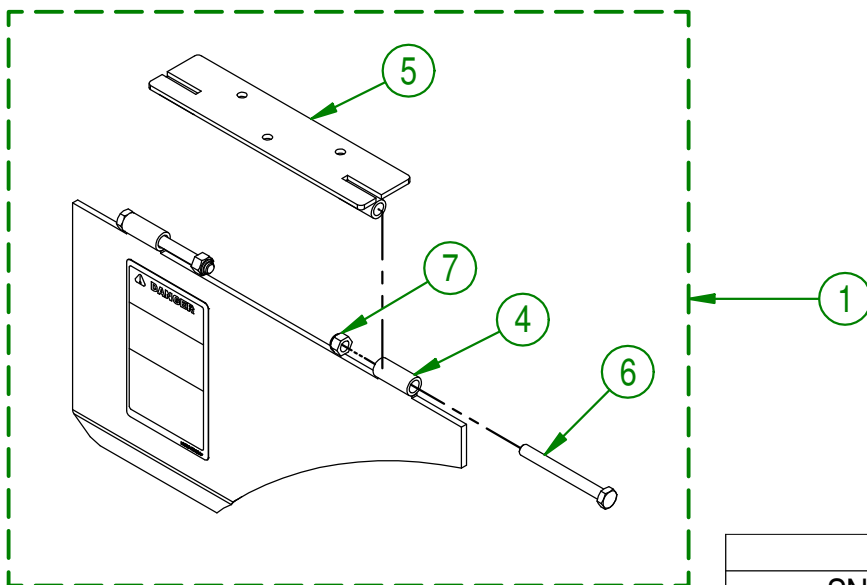
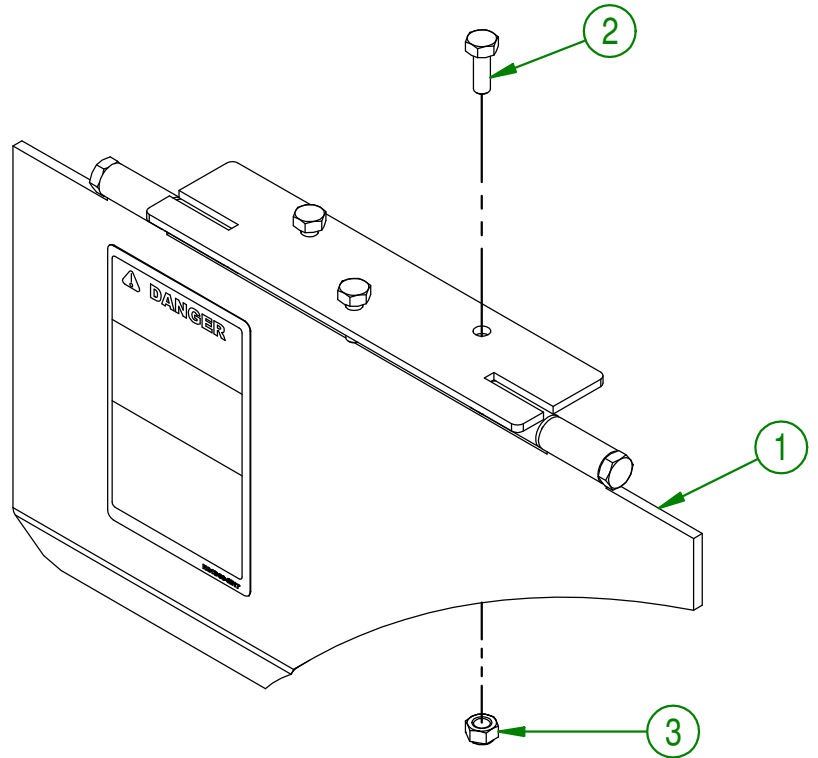

<b>AGRIMETAL</b>	
<b>SNOW GUARD (INSIDE RIGHT) GROUP.</b>	
CREATION : 12/09/18	ASSEMBLY : <b>44-57-0092</b>
REVISION : 02/10/18	AUTHOR : J.KABWE   Page 8 de 26

44-57-0093

#	PART #	Qty	TITLE
1	44-55-0093	1	SNOW GUARD (INSIDE LEFT) ASSY.
2	NC01-37-0004	3	HEX. BOLT GR2 ZINC 1/4-28 X 3/4"
3	NC01-97-0004	3	NYLON-INSERT LOCKNUT ZINC 1/4-28

44-55-0093

#	PART #	Qty	TITLE
4	44-57-0097	1	SNOW GUARD (INSIDE LEFT) STICKER INCLUDED
5	46-50-0095	1	SNOW GUARD SUPPORT
6	NC01-17-0068	2	HEX. BOLT GR2 NC ZINC 5/16-18 X 3"
7	NC01-96-0010	2	NYLON NUT HEX. ZINC 5/16-18

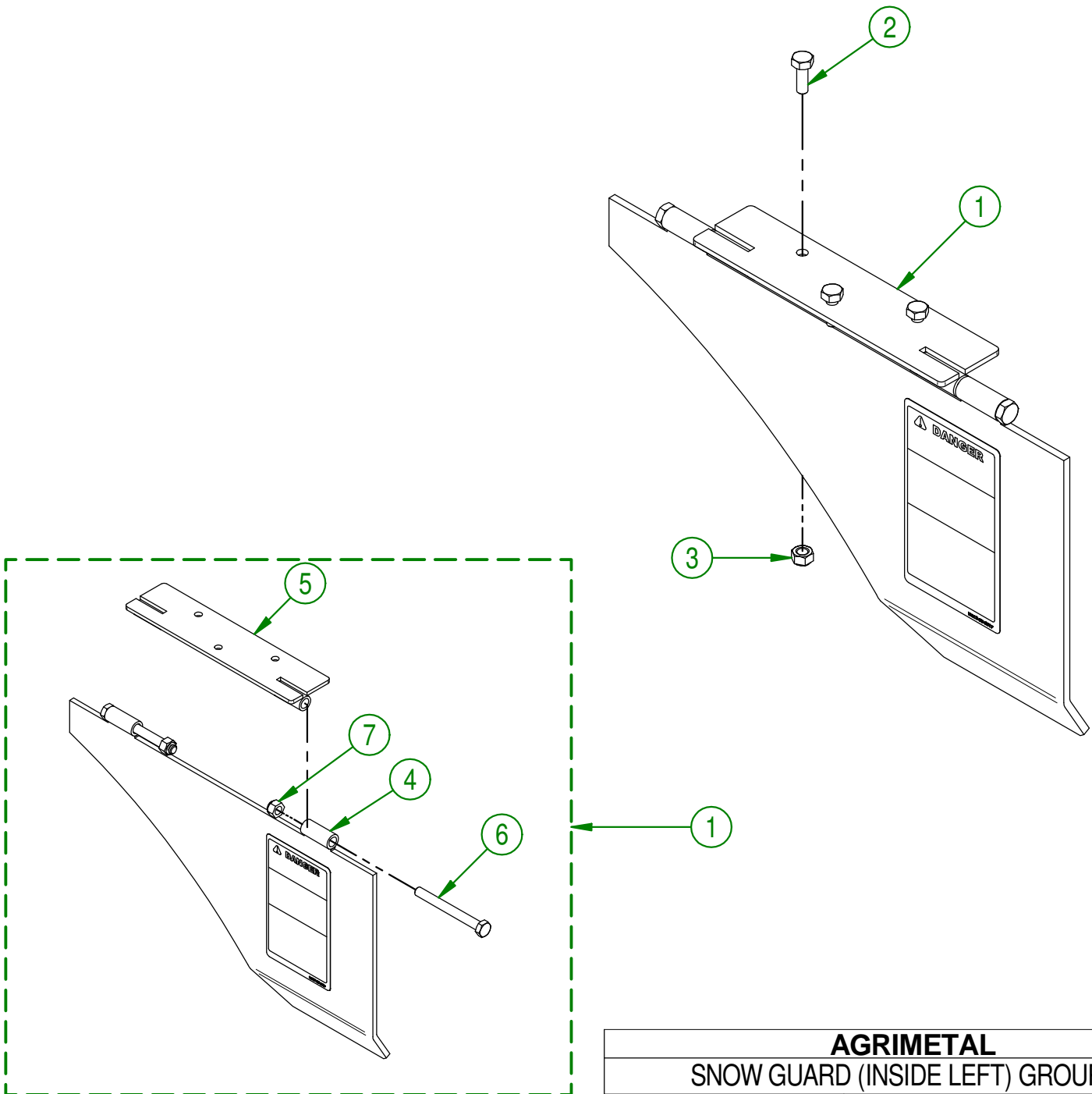

<b>AGRIMETAL</b>	
<b>SNOW GUARD (INSIDE LEFT) GROUP.</b>	
CREATION : 12/09/18	ASSEMBLY : <b>44-57-0093</b>
REVISION : 02/10/18	AUTHOR : J.KABWE
	Page 9 de 26

#	PART #	Qty	TITLE
1	44-01-1030	1	SNOW GUARD REINFORCING
2	NCI3-15-0093	2	SNOW GUARD
3	44-01-1020	2	SNOW GUARD BOTTOM
4	44-01-1025	2	SNOW GUARD BOTTOM
5	NC01-04-0005	28	CARR. BOLT GR2 ZINC 1/4-20 X 1"
6	NC01-96-0009	28	NYLON-INSERT LOCKNUT ZINC 1/4-20

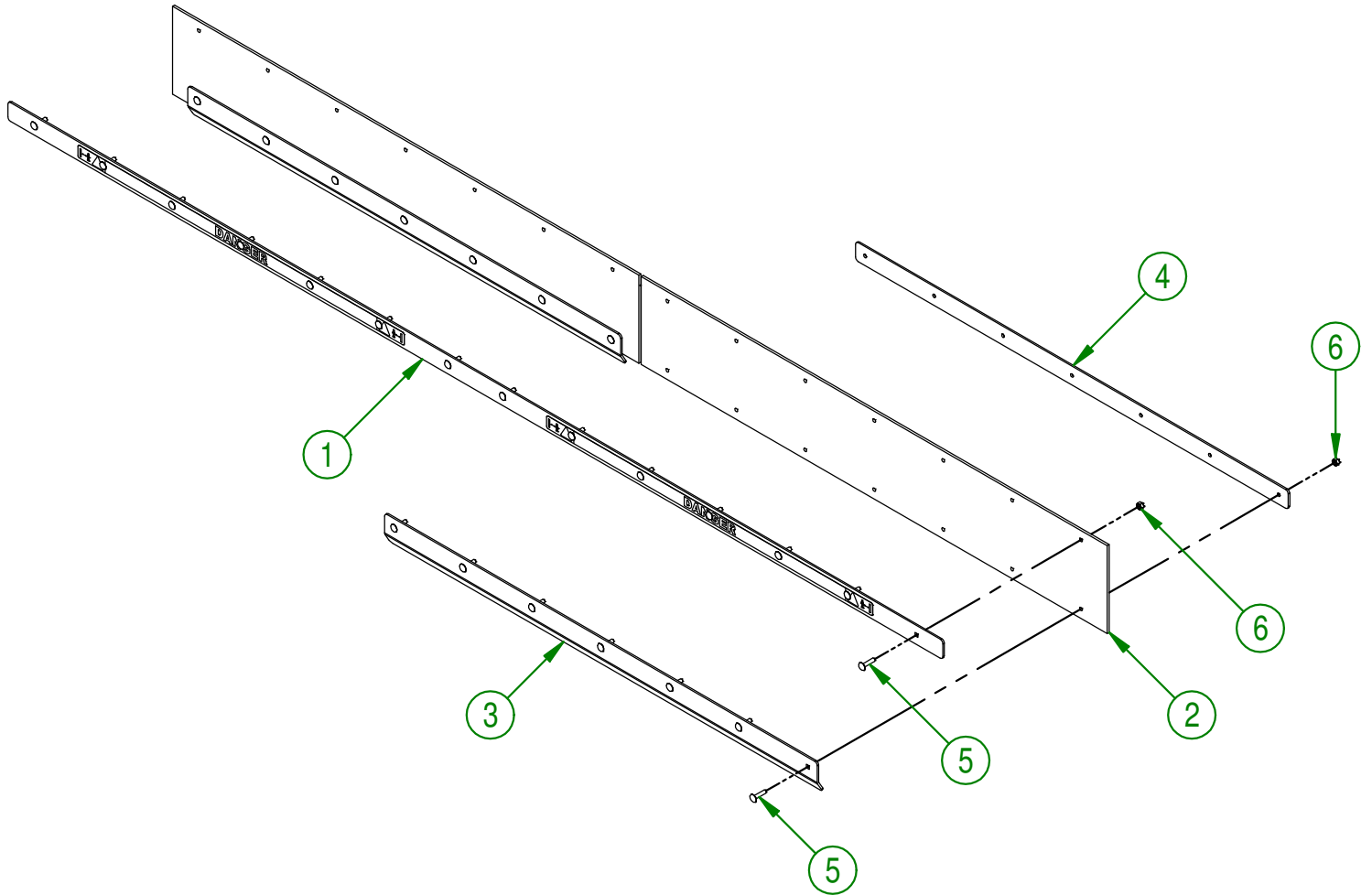

<b>AGRIMETAL</b>	
<b>SNOW GUARD GROUP</b>	
CREATION : 12/09/18	ASSEMBLY : <b>44-57-0035</b>
REVISION : 12/09/18	AUTHOR : J.KABWE   Page 10 de 26

#	PART #	Qty	TITLE
1	44-55-0551	1	PTO SHAFT ASSY.
2	NC14-75-0027	2	MOUNTED BALL BEARING WITH 4 BOLTS UCF309-28   3/4" ID
3	NC02-32-0017	8	LOCK WASHER ZINC 3/4"
4	NC01-17-0467	4	HEX. BOLT GR2 ZINC 3/4-10 X 2"
5	49-22-1405	4	WASHER
6	49-30-9955	4	BALL BEARING BOLT
7	NC13-15-0098	1	O-RING 1/16 XI/2 X 1 5/8
8	44-04-0030	1	PTO SHAFT BEARING PLATE
9	NC02-07-0023	4	HEX. NUT ZINC 3/4-10
10	44-34-0030	1	PTO SHAFT T90 540 RPM (MTC4692 & MTC 4386)
11	49-22-1810	8	WASHER
12	NC01-17-0114	8	HEX. BOLT GR2 ZINC 3/8-16 X 1"

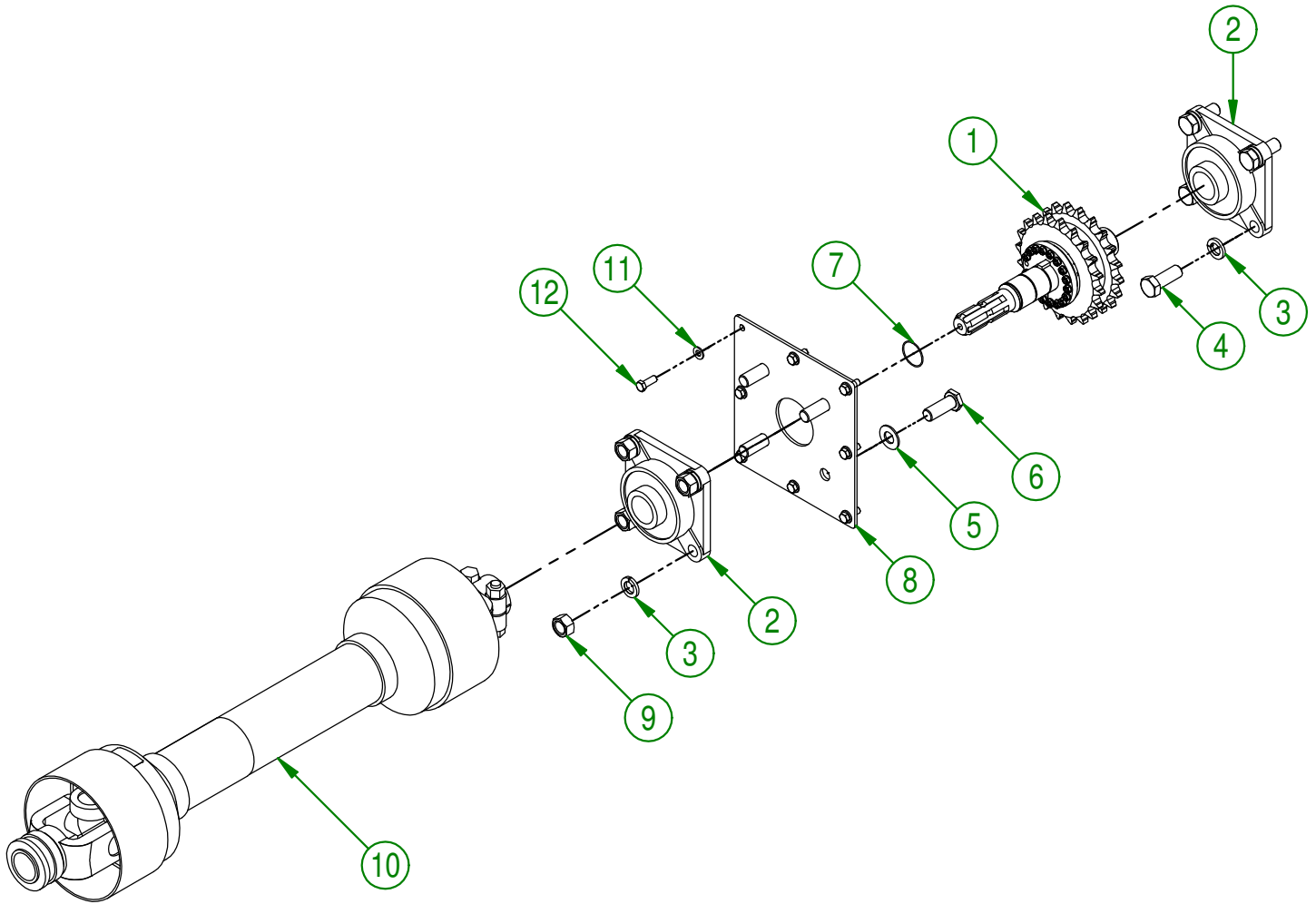

<b>AGRIMETAL</b>	
<b>DRIVE GROUP (PTO)</b>	
CREATION : 12/09/18	ASSEMBLY : <b>44-57-0050</b>
REVISION : 12/09/18	AUTHOR : J.KABWE   Page 11 de 26

#	PART #	Qty	TITLE
1	NC14-75-0027	2	MOUNTED BALL BEARING WITH 4 BOLTS UCF309-28   3/4" ID
2	44-50-0560	1	IMPELLER SPROCKET SHAFT (RIGHT)
3	44-20-0050	1	IMPELLER SHAFT
4	44-21-0005	4	BUSHING
5	NC01-17-0467	8	HEX. BOLT GR2 ZINC 3/4-10 X 2"
6	NC02-32-0017	8	LOCK WASHER ZINC 3/4"
7	NC02-07-0023	4	HEX. NUT ZINC 3/4-10
8	NC01-17-0122	2	HEX. BOLT GR2 ZINC 3/8-16 X 3"
9	NC02-32-0012	2	LOCK WASHER ZINC 3/8"
10	NC02-07-0018	2	HEX. NUT ZINC 3/8-16
11	NC13-15-0098	5	O-RING 1/16 XI/2 X I 5/8
12	44-41-0905	2	IMPELLER SHAFT KEY WAY
13	44-41-0910	2	KEY
14	49-13-2610	1	WASHER
15	NC02-32-0016	1	LOCK WASHER ZINC 5/8"
16	NC01-29-0394	1	HEX. BOLT GR5 NF ZINC 5/8-18 X I 1/2"
17	44-37-1015	1	CHAIN #80 HD X 67 3/4" (MTC 4386)

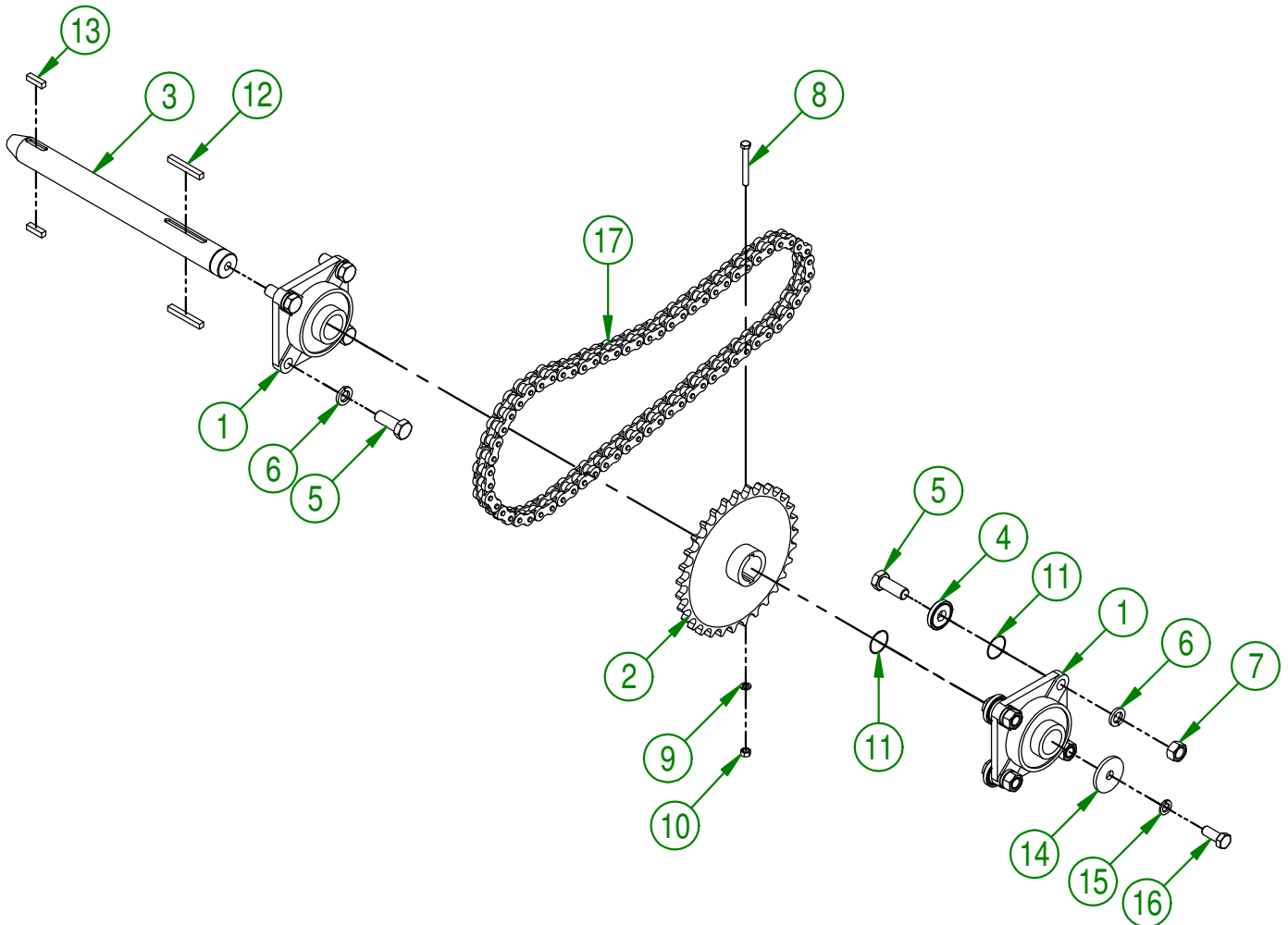
**AGRIMETAL****IMPELLER DRIVE GROUP. (RIGHT)**

CREATION : 13/09/18  
 REVISION : 02/10/18

ASSEMBLY : **44-57-0040**

AUTHOR : J.KABWE Page 12 de 26



#	PART #	Qty	TITLE
1	NC14-75-0158	2	MOUNTED BALL BEARING WITH 4 BOLTS UCF208-24 1 1/2" ID
2	44-13-2000	1	AUXILIARY SPROCKET SHAFT
3	44-41-0915	1	KEY
4	44-36-0620	1	AUXILIARY SPROCKET
5	NC13-80-0061	8	PAD STEEL POWDER 1/2" X 5/8" X 3/8"
6	NC02-44-1142	1	SET SCREW 1/2-20 X 1/2"
7	NC02-32-0014	8	LOCK WASHER ZINC 1/2"
8	NC01-29-0249	8	HEX. BOLT GR5 NF ZINC 1/2-20 X 1 1/2"

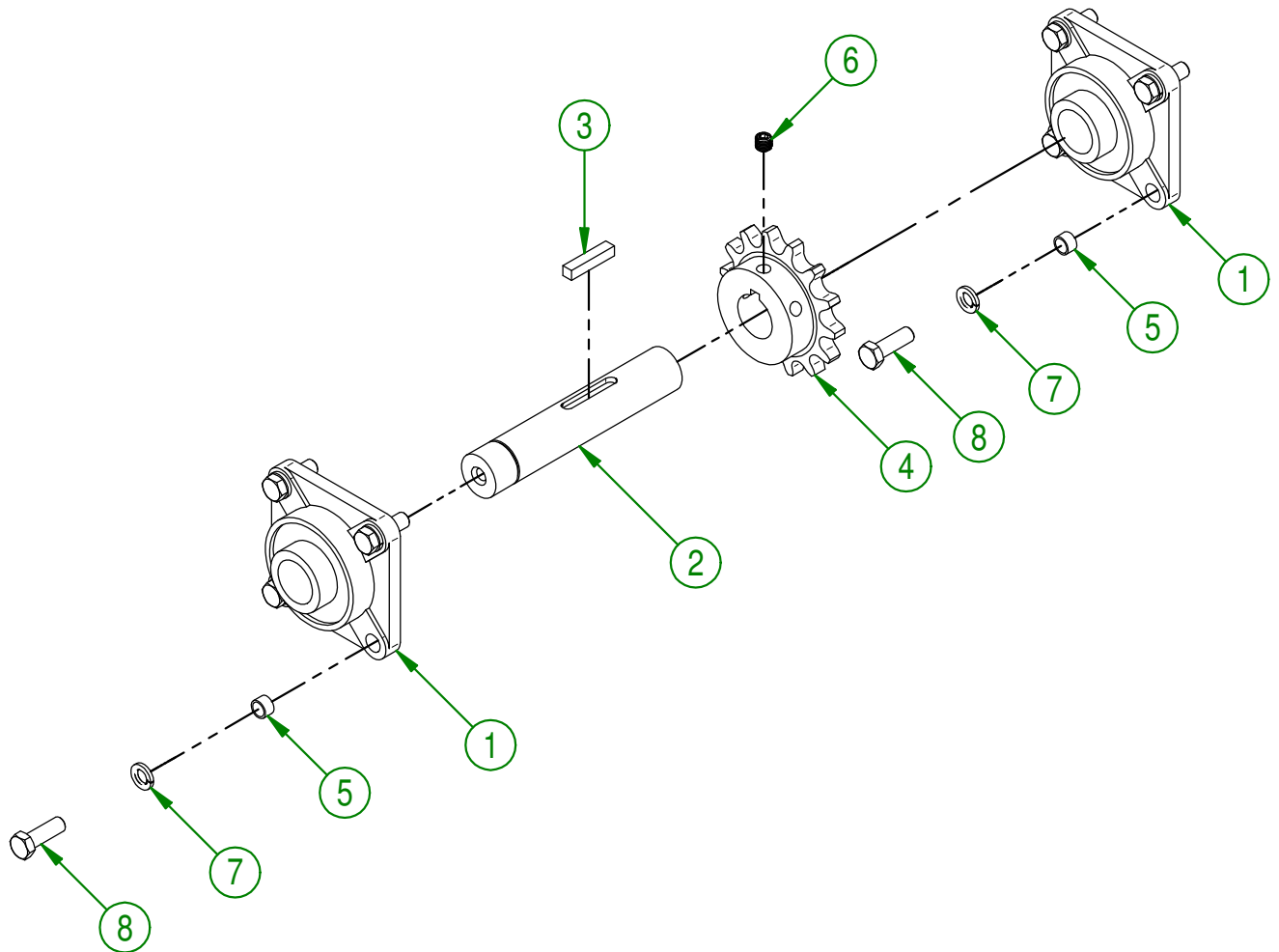

<b>AGRIMETAL</b>	
<b>AUXILIARY SPROCKET GROUP. (TOP &amp; BOTTOM)</b>	
CREATION : 12/09/18	ASSEMBLY : <b>44-57-0055</b>
REVISION : 12/09/18	AUTHOR : J.KABWE   Page 14 de 26

#	PART #	Qty	TITLE
1	44-55-0517	1	CHAIN TIGHTENER (OIL) (RIGHT) ASSY.
2	44-50-0525	1	CHAIN TIGHTENER STOPPER "WITH PLATE"
3	44-09-1200	1	CHAIN TIGHTENER PIVOT
4	NC01-37-0115	4	HEX. BOLT GR8 NF ZINC 3/8-24 X 1 1/4"
5	21-01-0950	4	FLAT WASHER 10GA 1.005" DIA X 25/64"
6	NC02-07-0018	4	HEX. NUT ZINC 3/8-16
7	49-22-1400	1	WASHER
8	NC01-33-0410	1	HEX. BOLT GR8 NC ZINC 5/8-11 X 5 1/2"
9	NC13-85-0050	1	COMP. SPRING .100" WIRE X 1.030" ID X 9"
10	49-31-0405	1	1"-14 THREAD ROD
11	44-50-0110	1	TIGHTENER SPRING BOX
12	NC02-18-8143	1	BLACK SHIM RINGS .134" X 1" X 1 1/2"
13	NC02-10-0025	1	HEX NUT 1-14
14	44-37-1017	1	CHAIN #80 HD X 6" (MTC 4386)
15	NC01-69-0415	1	SPRING PIN 3/16" X 3/4"

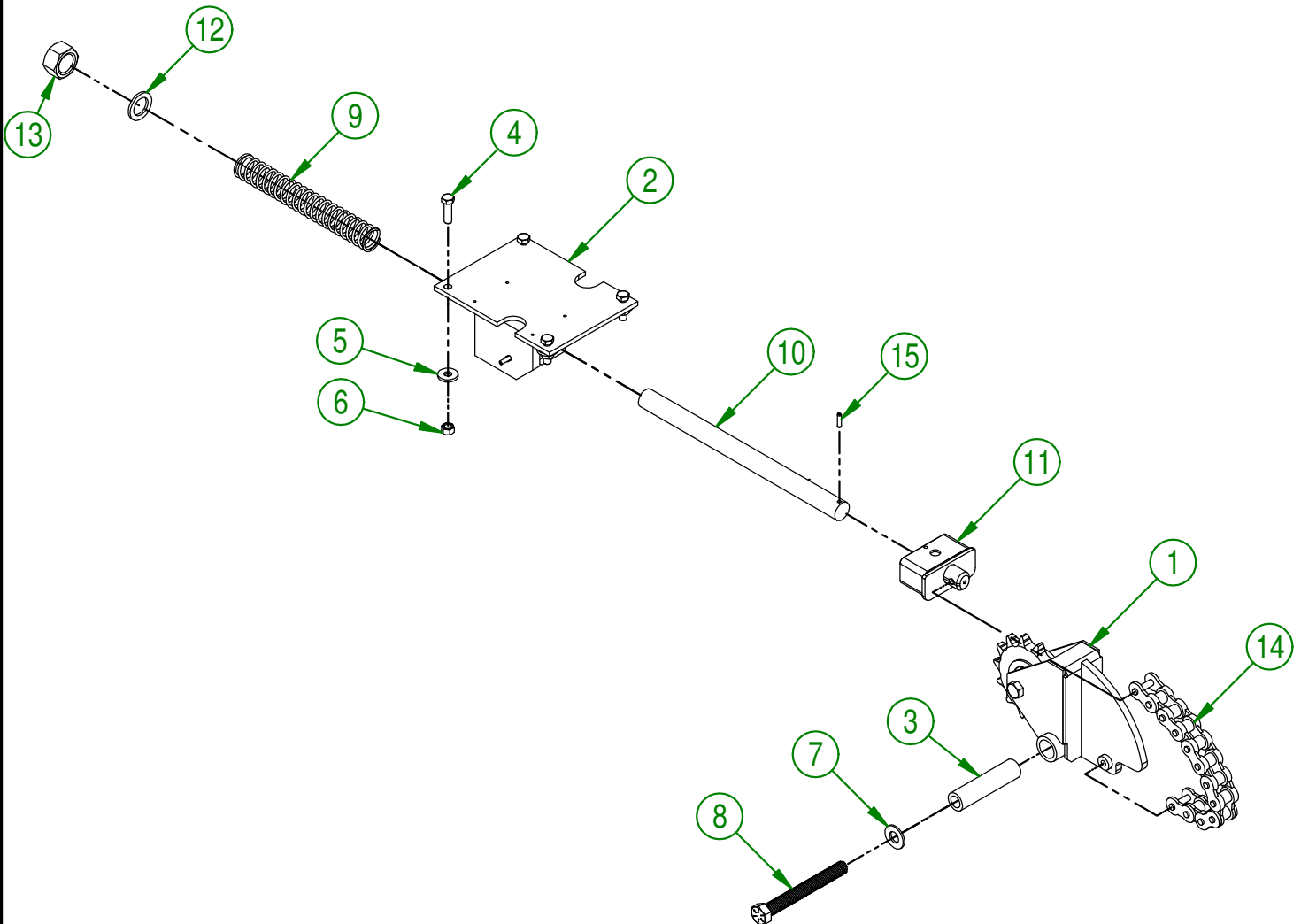
**AGRIMETAL****SPROCKET CHAIN TIGHTENER GROUP. (RIGHT)**

CREATION : 12/09/18  
 REVISION : 22/02/19

ASSEMBLY : **44-57-0060**

AUTHOR : J.KABWE Page 15 de 26

44-55-0517

#	PART #	Qty	TITLE
1	44-50-0020	1	CHAIN TIGHTENER (OIL)
2	44-55-0520	1	SPROCKET 80 X14 & BEARING 6205 X 1" DIA. ASSY.
3	48-13-1605	1	TIGHTENER SPROCKET SHAFT
4	48-13-1610	1	TIGHTENER SPROCKET SHAFT
5	NC01-17-0255	1	HEX. BOLT GR2 ZINC 1/2-13 X 3"
6	NC02-32-0014	1	LOCK WASHER ZINC 1/2"
7	NC02-07-0020	1	HEX. NUT ZINC 1/2-13

44-55-0520

#	PART #	Qty	TITLE
8	44-50-0563	1	TIGHTENER SPROCKET
9	NC01-64-0159	1	INTERNAL RETAINING RING 2 1/16" HOLE
10	NC14-75-0070	1	6205-2RS BEARING

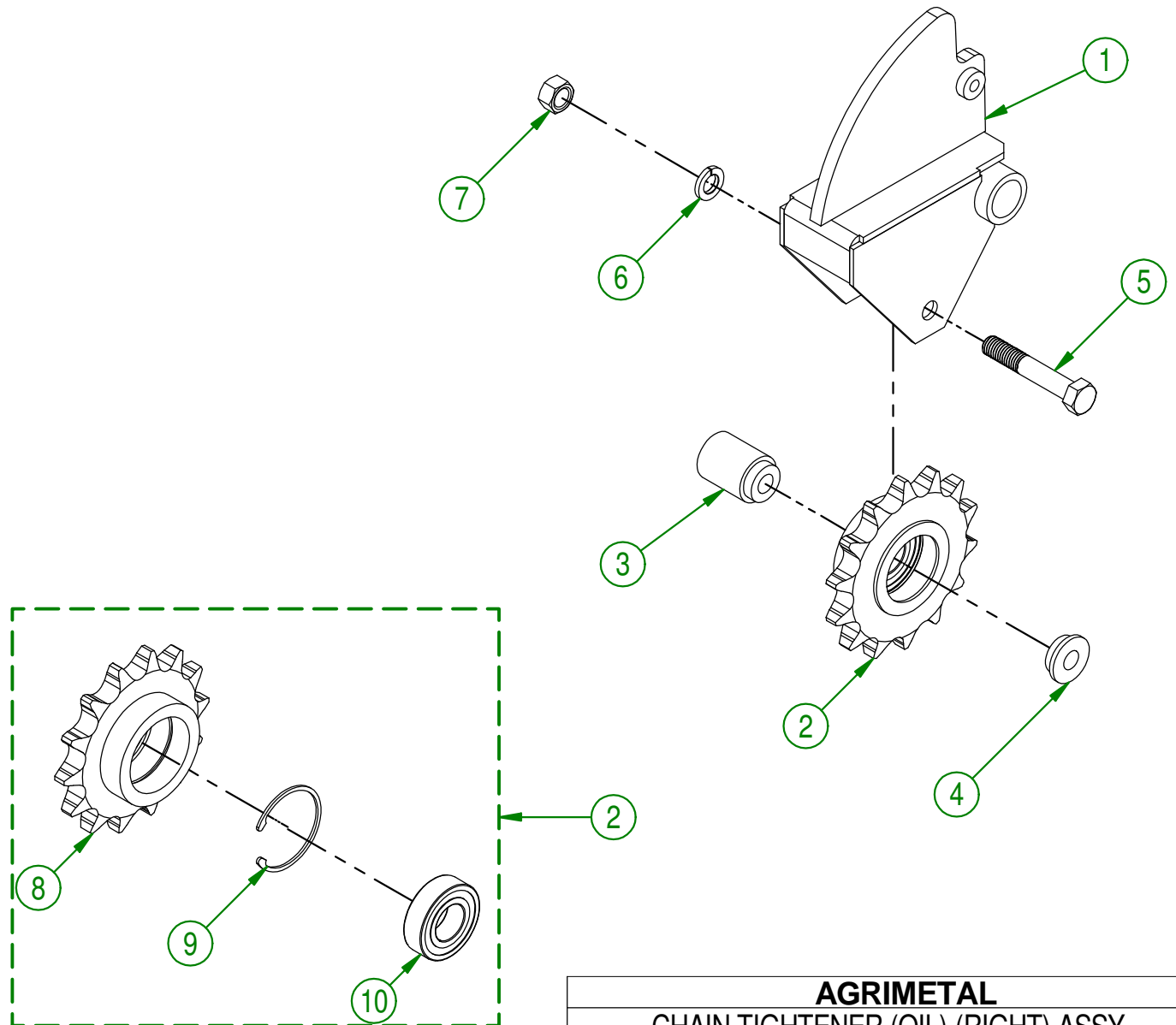

<b>AGRIMETAL</b>	
CHAIN TIGHTENER (OIL) (RIGHT) ASSY.	
CREATION : 12/09/18	ASSEMBLY : <b>44-55-0517</b>
REVISION : 12/09/18	AUTHOR : J.KABWE Page 16 de 26

#	PART #	Qty	TITLE
1	44-55-0518	1	CHAIN TIGHTENER (OIL) (LEFT) ASSY.
2	44-09-1200	1	CHAIN TIGHTENER PIVOT
3	49-22-1400	1	WASHER
4	NC01-33-0410	1	HEX. BOLT GR8 NC ZINC 5/8-11 X 5 1/2
5	49-37-1012	1	CHAIN #80 HD X 22"
6	44-50-0110	1	TIGHTENER SPRING BOX
7	49-31-0400	1	1"-14 THREAD ROD
8	49-50-0530	1	CHAIN TIGHTENER STOPPER (WITH BOLTS)
9	49-22-1810	4	WASHER
10	NC01-37-0114	4	BOLT GR8 3/8" X 1"
11	NC13-85-0050	1	COMP. SPRING .100" WIRE X 1.030" ID X 9"
12	NC02-18-8143	1	BLACK SHIM RINGS .134" X 1" X 1 1/2"
13	NC02-10-0025	1	HEX NUT 1-14
14	NC01-69-0415	1	SPRING PIN 3/16" X 3/4"

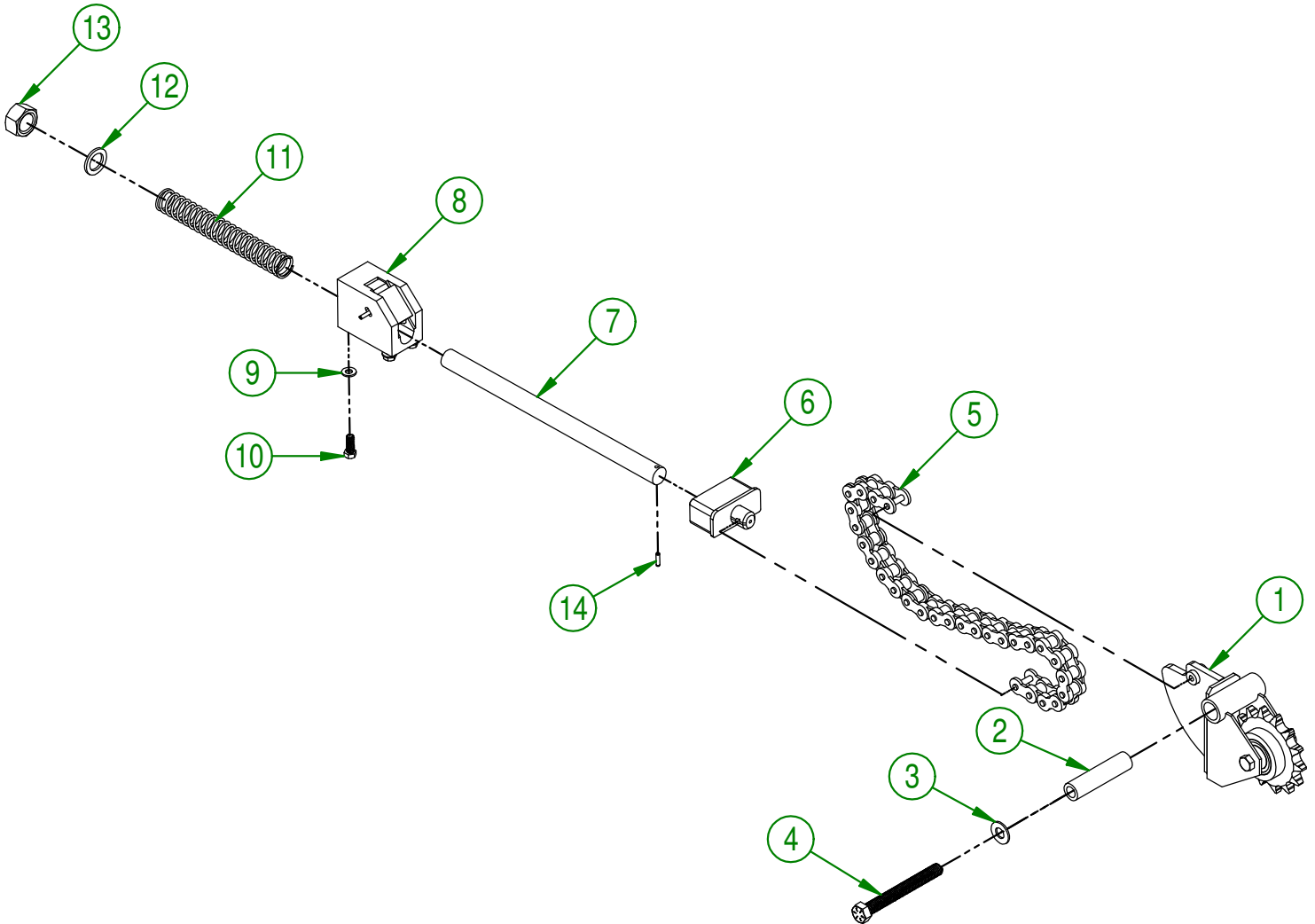
**AGRIMETAL****SPROCKET CHAIN TIGHTENER GROUP. (LEFT)**

CREATION : 13/09/18  
 REVISION : 22/02/19

ASSEMBLY : **44-57-0065**

AUTHOR : J.KABWE Page 17 de 26

44-55-0518

#	PART #	Qty	TITLE
1	44-50-0020	1	CHAIN TIGHTENER (OIL)
2	44-55-0520	1	SPROCKET 80 X14 & BEARING 6205 X 1" DIA. ASSY.
3	48-13-1605	1	TIGHTENER SPROCKET SHAFT
4	48-13-1610	1	TIGHTENER SPROCKET SHAFT
5	NC01-17-0255	1	HEX. BOLT GR2 ZINC 1/2-13 X 3"
6	NC02-32-0014	1	LOCK WASHER ZINC 1/2"
7	NC02-07-0020	1	HEX. NUT ZINC 1/2-13

44-55-0520

#	PART #	Qty	TITLE
8	44-50-0563	1	TIGHTENER SPROCKET
9	NC01-64-0159	1	INTERNAL RETAINING RING 2 1/16" HOLE
10	NC14-75-0070	1	6205-2RS BEARING

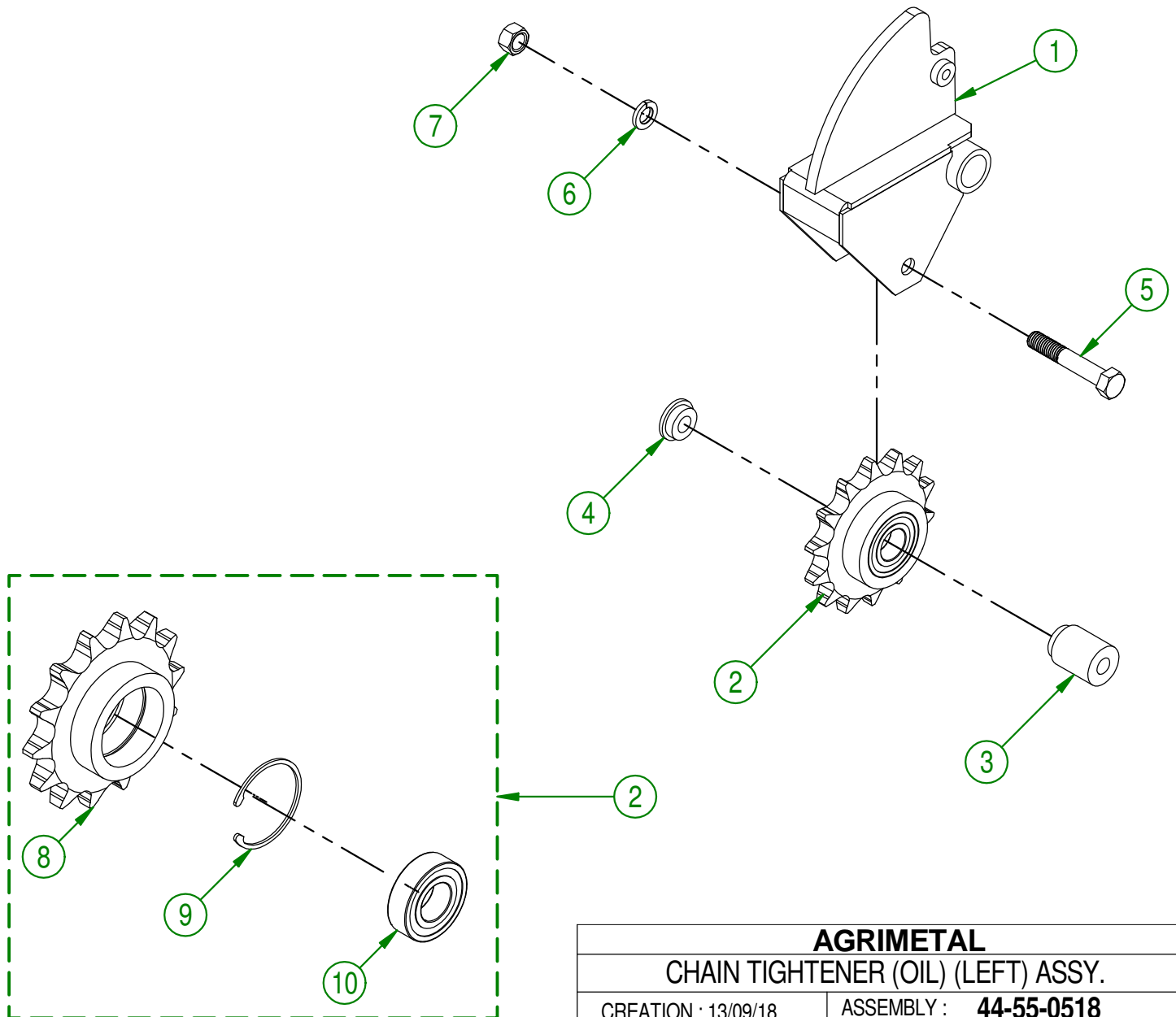

<b>AGRIMETAL</b>	
<b>CHAIN TIGHTENER (OIL) (LEFT) ASSY.</b>	
CREATION : 13/09/18	ASSEMBLY : <b>44-55-0518</b>
REVISION : 13/09/18	AUTHOR : J.KABWE   Page 18 de 26

#	PART #	Qty	TITLE
1	44-50-0030	1	OIL SLAB
2	NC02-25-0007	2	WASHER ZINC 0.281 = 9/32
3	NC01-17-0006	2	HEX. BOLT 1/4-20 X 1"
4	NC01-96-0009	2	NYLON-INSERT LOCKNUT ZINC 1/4-20

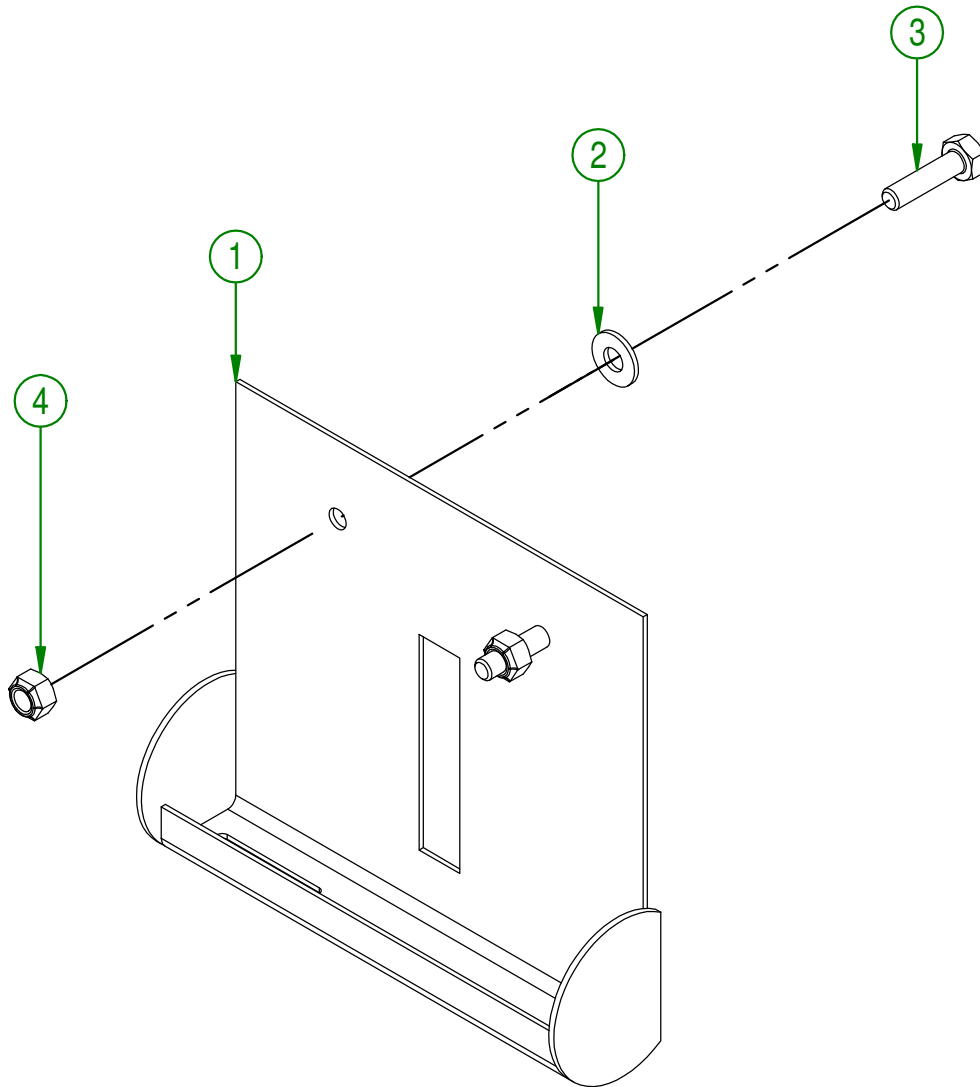

**AGRIMETAL**  
OIL SLAB GROUP.

CREATION : 13/09/18  
REVISION : 13/09/18

ASSEMBLY : **44-57-0080**

AUTHOR : J.KABWE Page 19 de 26

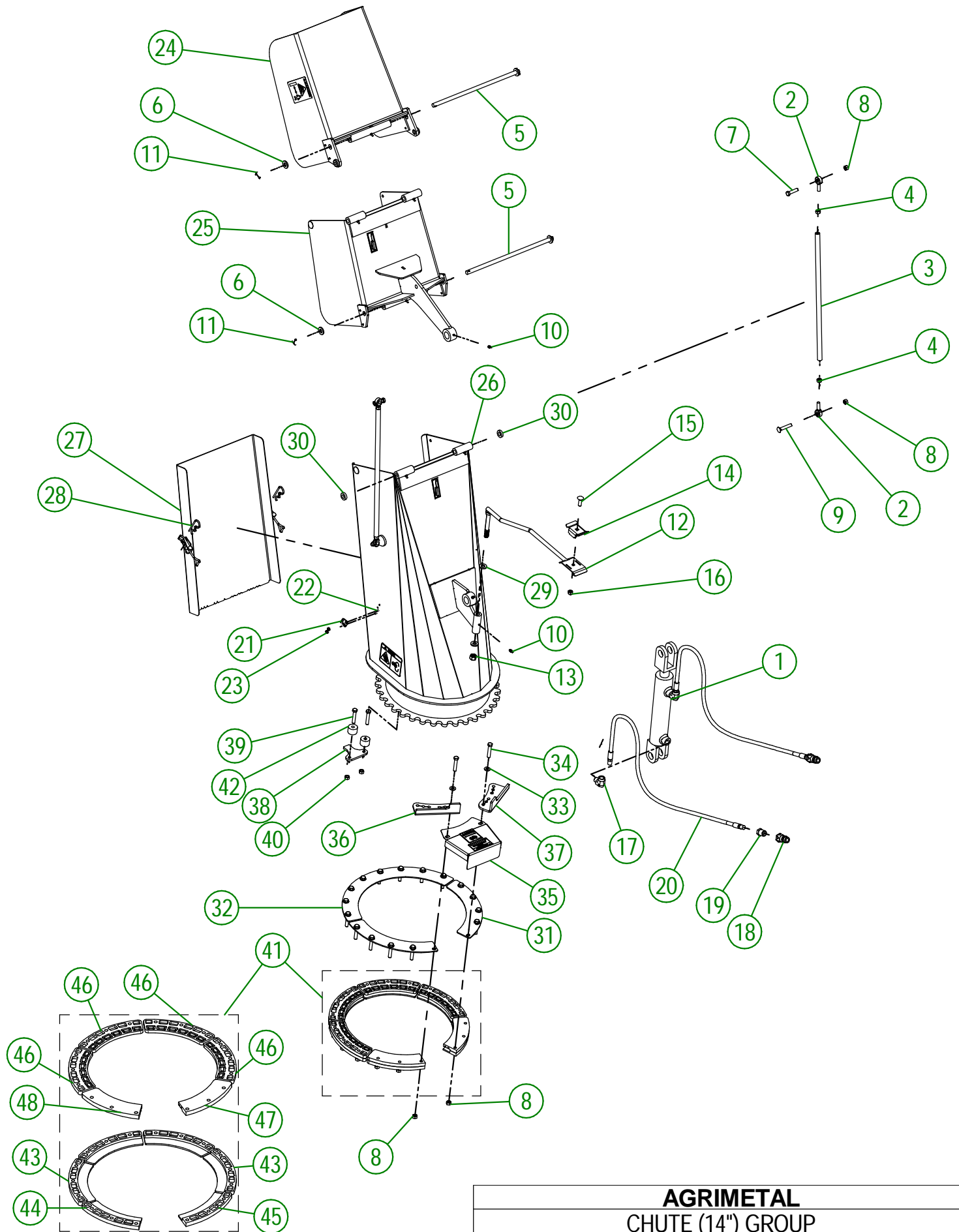

**AGRIMETAL**  
**CHUTE (14'') GROUP**

CREATION : 12/04/19  
 REVISION : 22/12/25

ASSEMBLY : **81-57-0331**  
 AUTHOR : dessin3

## 81-57-0331

#	PART#	QTY	TITLE
1	NC13-45-0404	1	HYDRAULIC CYLINDER 6"
2	NC01-67-0304	4	ROD END 3/8-24
3	48-13-0600	2	CHUTE ROD (DOUBLE)
4	NC02-10-0018	4	NUT 3/8-24
5	81-20-0250	2	PIVOT
6	NC02-25-0011	4	WASHER SAE ZINC 17/32 ID
7	NC01-25-0116	2	HEX. BOLT GR5 ZINC 3/8-16 X 1 1/2"
8	NC01-93-0011	22	LOCK NUT 3/8-16
9	NC01-07-0113	2	CARR. BOLT GR5 ZINC 3/8-16 X 2" LG
10	NC01-69-0785	9	STRAIGHT GREASE FITTING 1/4-28
11	NC01-69-0139	4	COTTER PIN ZINC 1/8" X 3/4"
12	48-50-1030	1	HYDRAULIC HOSE SUPPORT
13	NC01-96-0014	1	NYLON-INSERT LOCKNUT ZINC 1/2-13
14	48-01-7530	1	HYDRAULIC HOSE SUPPORT
15	NC01-04-0110	1	CARR. BOLT GR2 ZINC 3/8-16 X 1 1/4"
16	NC01-96-0011	1	NYLON NUT 3/8-16
17	NC13-45-0038	2	ELBOW 90 3/8 FEM. NPT X 3/8 MALE NPT
18	NC13-45-0369	2	QUICK COUPLER 1/2-14 NPTF
19	NC13-45-0153	2	HEX. REDUCER 1/4 NPT X 1/2 NPT
20	NC17-02-0347	2	HYDRAULIC HOSE (111" LG)
21	NC01-63-0052	2	ADJUSTABLE LATCH (STRIKE)
22	NC02-40-0080	4	MACHINE SCREWS SQUARE SOCKET #10-24 X 1/2" LG
23	NC01-96-0006	4	NYLON NUT ZINC 3/16
24	81-57-0321	1	CHUTE (TOP SECTION)
25	81-57-0311	1	CHUTE (MIDDLE SECTION)
26	81-57-0302	1	CHUTE (BOTTOM SECTION)
27	81-57-0353	1	CHUTE DOOR
28	NC01-63-0026	2	COTTER PIN ZC 5/32" X 3"
29	NC02-25-0011	2	WASHER SAE ZINC 17/32 ID
30	NC13-15-0334	2	PIVOT WASHER
31	48-01-1165	2	BRACE
32	48-01-1167	1	BRACE
33	NC02-26-1525	18	WASHER INOX .406" D.I. X .815" D.E.
34	NC01-17-0118	18	HEX. BOLT GR2 ZINC 3/8-16 X 2"
35	80-57-0550	1	SPROCKET GUARD GROUP "STICKER INCLUDED"
36	81-04-0175	1	ADJUSTABLE STOPPER
37	81-04-0177	1	ADJUSTABLE STOPPER
38	84-04-0170	1	STOPPER
39	NC01-37-0118	2	HEX. BOLT GR8 ZINC 3/8-24 X 2"
40	NC01-94-0011	2	LOCK NUT 3/8-24
41	81-57-0550	1	CHUTE GUIDE GROUP
42	81-21-0040	2	ADJUSTABLE STOPPER SPACER

## 81-57-0550

#	PART#	QTY	TITLE
43	NC17-46-0025	4	CHUTE GUIDE (UNDER)
44	48-42-0305	1	CHUTE GUIDE (UNDER)
45	48-42-0310	1	CHUTE GUIDE (UNDER)
46	NC17-46-0026	4	CHUTE GUIDE (TOP)
47	48-42-0320	1	CHUTE GUIDE (TOP)
48	48-42-0315	1	CHUTE GUIDE (TOP)



#	PART #	Qty	TITLE
1	NC13-30-0237	1	PLASTIC TUBE FOR OPERATOR'S MANUAL
2	44-98-0601	1	OPER. MAN. 3 POINT HITCH SNOW BLOWER
3	NC02-22-0008	2	WASHER ZINC 5/16"
4	NC01-17-0007	2	HEX. BOLT GR2 ZINC 1/4-20 X 1 1/4"
5	NC01-96-0009	2	NYLON-INSERT LOCKNUT ZINC 1/4-20

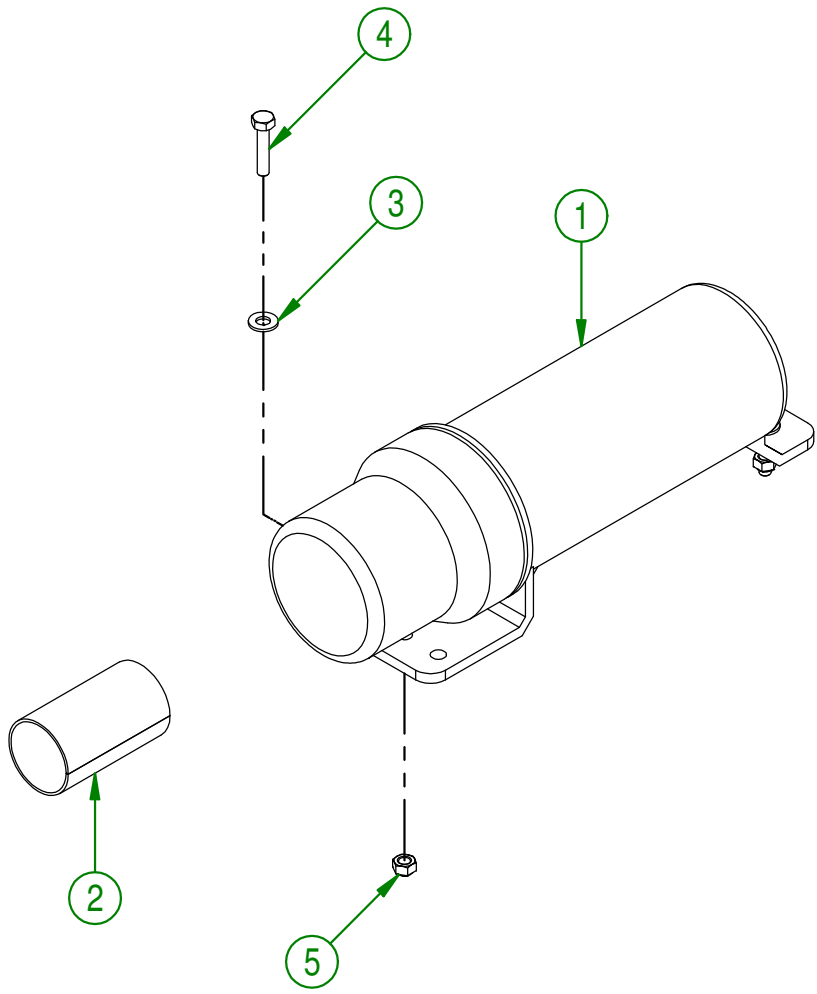

<b>AGRIMETAL</b>	
OPER. MAN. MAX TWIN GROUP	
CREATION : 13/09/18	ASSEMBLY : <b>44-57-0070</b>
REVISION : 20/09/18	AUTHOR : J.KABWE   Page 23 de 26

#	PART #	Qty	TITLE
1	48-50-1085	1	PTO SUPPORT
2	01-01-2485	2	FLAT WASHER
3	NC02-32-0012	2	LOCK WASHER ZINC 3/8"
4	NC02-07-0018	2	HEX. NUT ZINC 3/8-16

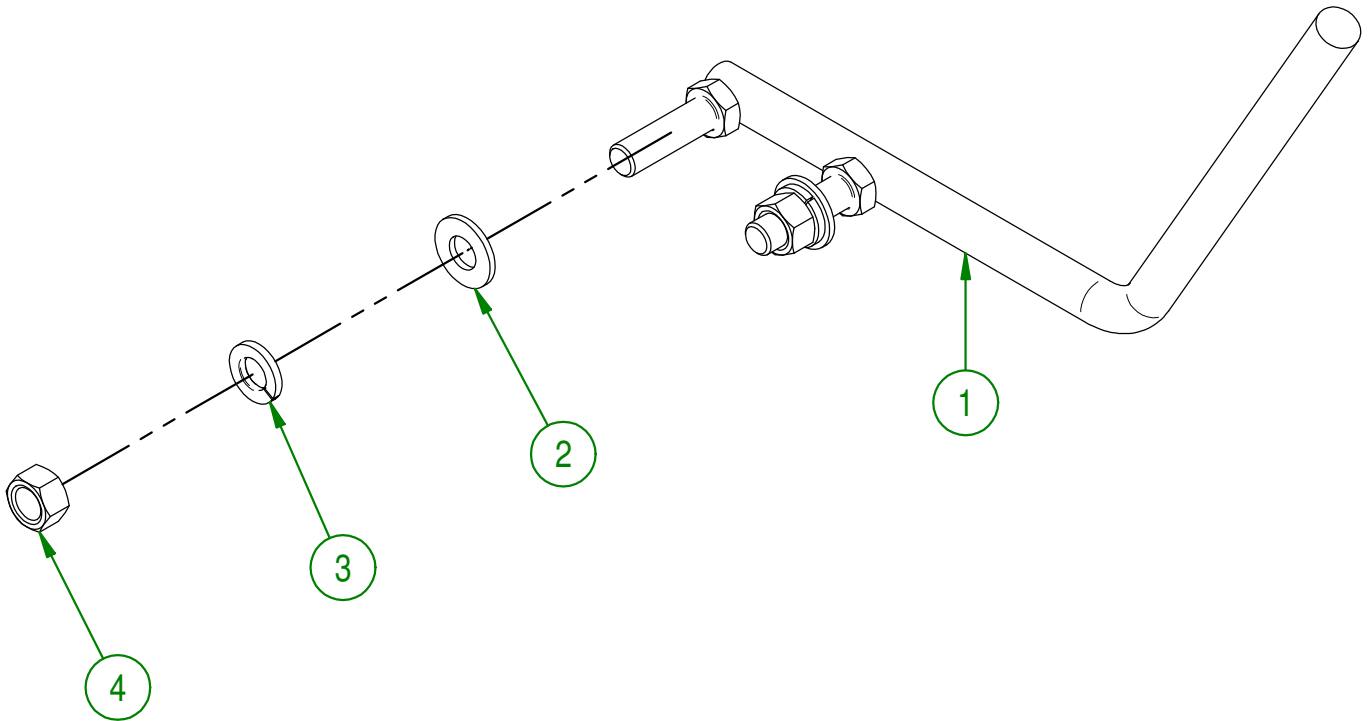

<b>AGRIMETAL</b>	
PTO SUPPORT GROUP.	
CREATION : 04/06/18	ASSEMBLY : <b>48-57-1165</b>
REVISION : 04/06/18	AUTHOR : J.KABWE   Page 24 de 26

#	PART #	Qty	TITLE
1	44-50-0535	2	ADJUSTABLE SKATE
2	49-20-0210	2	ADJUSTABLE SKATE PIN
3	NC01-63-0026	2	COTTER PIN ZC 5/32" X 3"

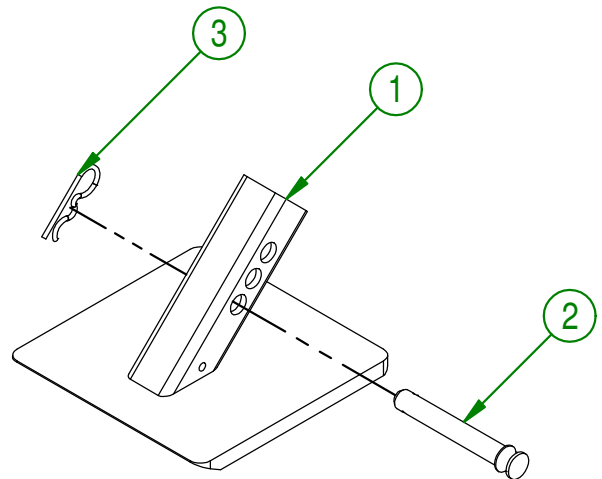
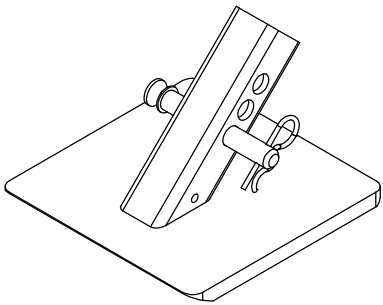

<b>AGRIMETAL</b>	
<b>ADJUSTABLE SKATE GROUP</b>	
CREATION : 13/09/18	ASSEMBLY : <b>44-57-0085</b>
REVISION : 13/09/18	AUTHOR : J.KABWE   Page 25 de 26

#	PART #	Qty	TITLE
1	NCI3-33-0108	1	STICKER CAUTION
2	NCI3-33-0024	9	STICKER GREASE HERE
3	NCI3-33-0035	1	STICKER AGRIMETAL
4	NCI3-33-0275	1	STICKER PICTOGRAM
5	NCI3-33-0005	1	STICKER MAXIMUM 540 RPM
6	NCI3-33-0317	1	STICKER GREASE DRIVE LINE TELESCOPIC SHAFT
7	NCI3-33-0201	1	STICKER MAX-TWIN
8	NCI3-33-0229	1	STICKER 4386
9	NCI3-33-0211	1	STICKER IMPORTANT
10	25-55-0710	1	SERIAL NUMBER PLATE
11	NCI3-33-0017	2	STICKER WARNING
12	NCI3-33-0003	1	STICKER OIL LEVEL
13	NCI3-33-0217	4	STICKER DANGER
14	NCI3-33-0274	2	STICKER DANGER
15	NCI4-85-0276	1	STICKER (DANGER-PLASTIC GUARD)
16	NCI3-33-0310	1	STICKER T90
17	NCI3-33-0192	2	STICKER (PROJECTION RISK)
18	NCI3-33-0249	3	STICKER DANGER
19	NCI3-33-0020	2	STICKER DANGER

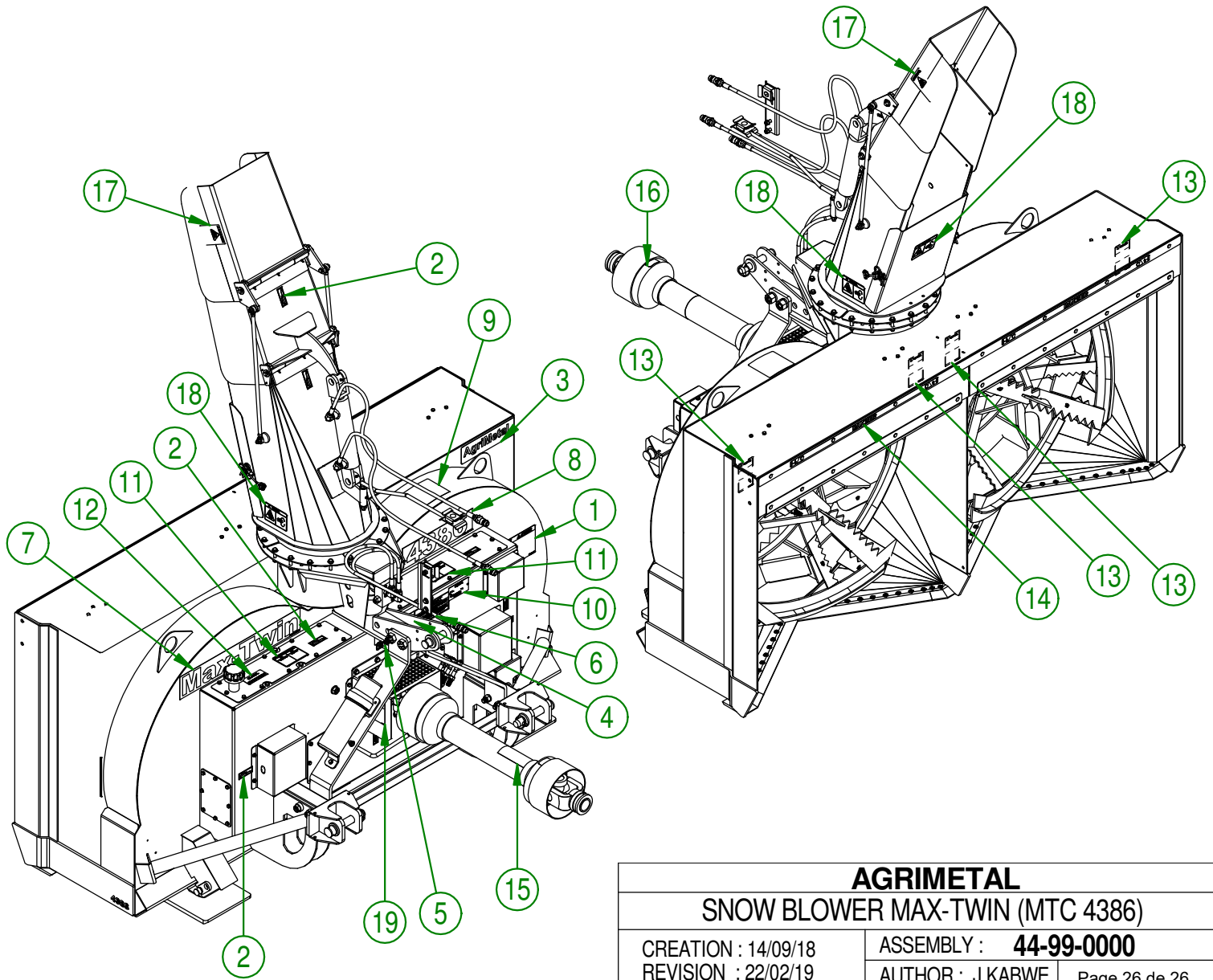

<b>AGRIMETAL</b>	
<b>SNOW BLOWER MAX-TWIN (MTC 4386)</b>	
CREATION : 14/09/18	ASSEMBLY : <b>44-99-0000</b>
REVISION : 22/02/19	AUTHOR : J.KABWE Page 26 de 26