

AgriMetal

PARTS LIST

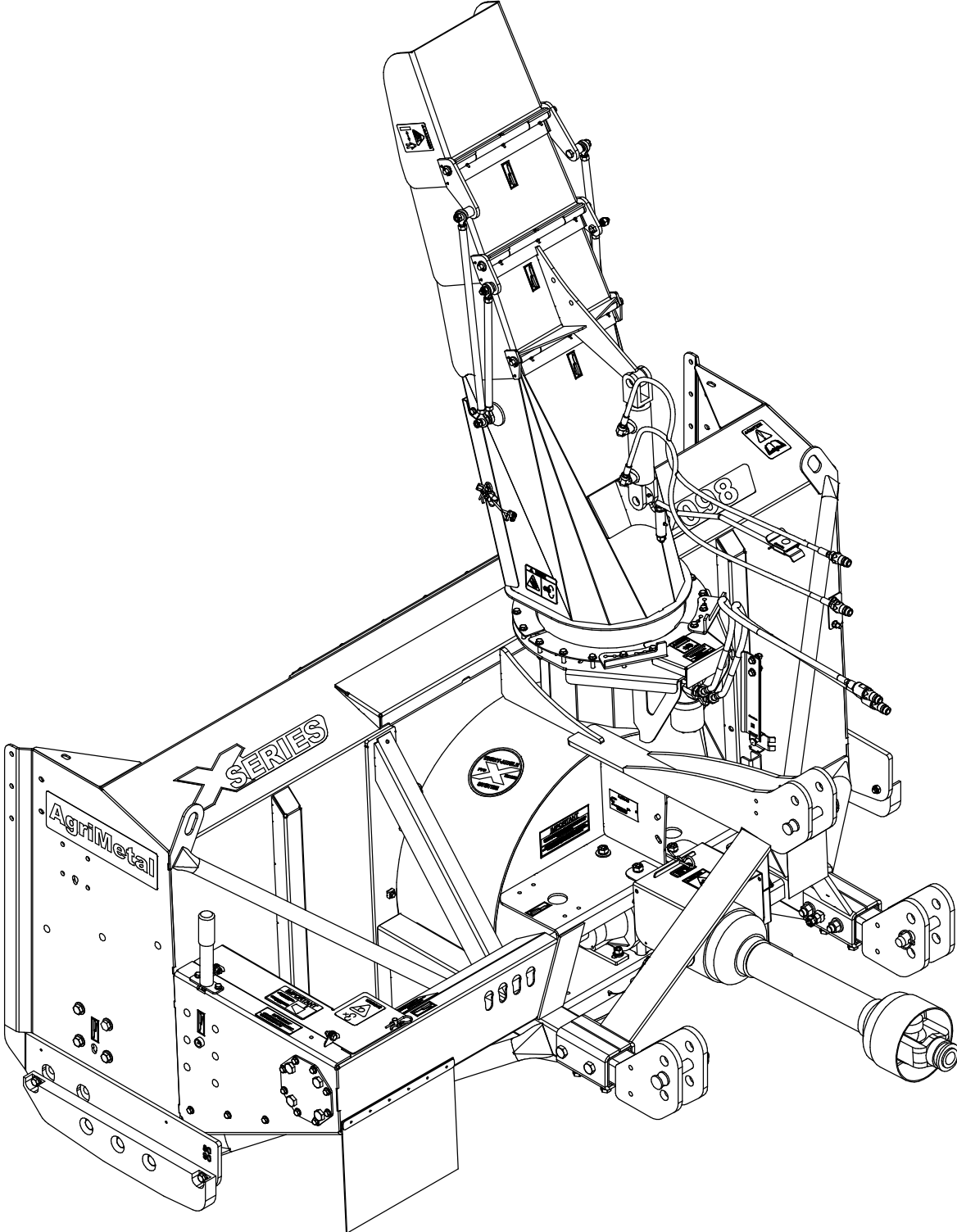

X-12098

102-57-0065

#	PART #	Qty	TITLE
1	102-20-0030	2	SKATE (STAINLESS)
2	80-50-0087	2	LATERAL SKATE (STAINLESS STEEL)
3	81-57-0235	2	KNIFE (STAINLESS STEEL) GROUP (BOLTS AND NUTS INCLUDED)
4	NC02-48-0562	10	FLAT HEAD SOCKET CAP SCREW STAINLESS 5/8-11 X 1 1/2"
5	NC02-48-0586	4	FLAT HEAD SOCKET CAP SCREW 5/8-11 X 1" LG

81-57-0235

#	PART #	QTY	TITLE
6	NC01-93-0016	5	LOCK NUT ZINC 5/8-11
7	NC02-48-0562	5	FLAT HEAD SOCKET CAP SCREW STAINLESS 5/8-11 X 1 1/2"

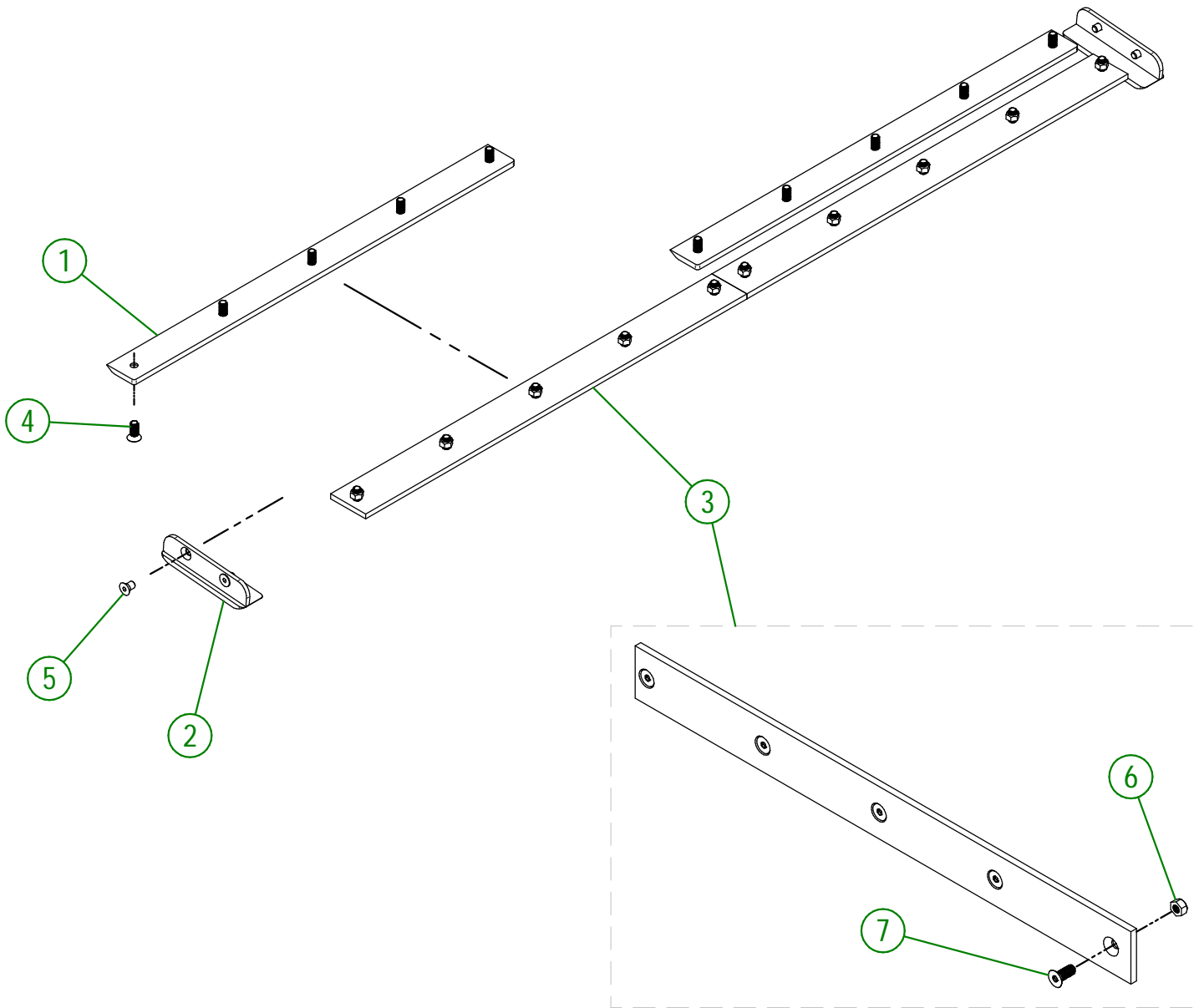

AGRIMETAL	
SET OF KNIVES (STAINLESS STEEL)	
CREATION : 23/08/23	ASSEMBLY : 102-57-0065
REVISION : 12/03/26	AUTHOR : J. Houle

102-57-0070

#	PART #	Qty	TITLE
1	102-04-0130	2	SKATE (#450 HARDNESS STEEL)
2	80-50-0085	2	LATERAL SKATE (#450 HARDNESS STEEL)
3	81-57-0230	2	KNIFE (#450 HARDNESS STEEL) GROUP (BOLTS AND NUTS INCLUDED)
4	NC02-48-0562	10	FLAT HEAD SOCKET CAP SCREW STAINLESS 5/8-11 X 1 1/2"
5	NC02-48-0586	4	FLAT HEAD SOCKET CAP SCREW 5/8-11 X 1" LG

81-57-0230

#	PART #	QTY	TITLE
6	NC01-09-0039	5	PLOW BOLT GR5 5/8-11 X 1 1/2" LG
7	NC01-93-0016	5	LOCK NUT ZINC 5/8-11

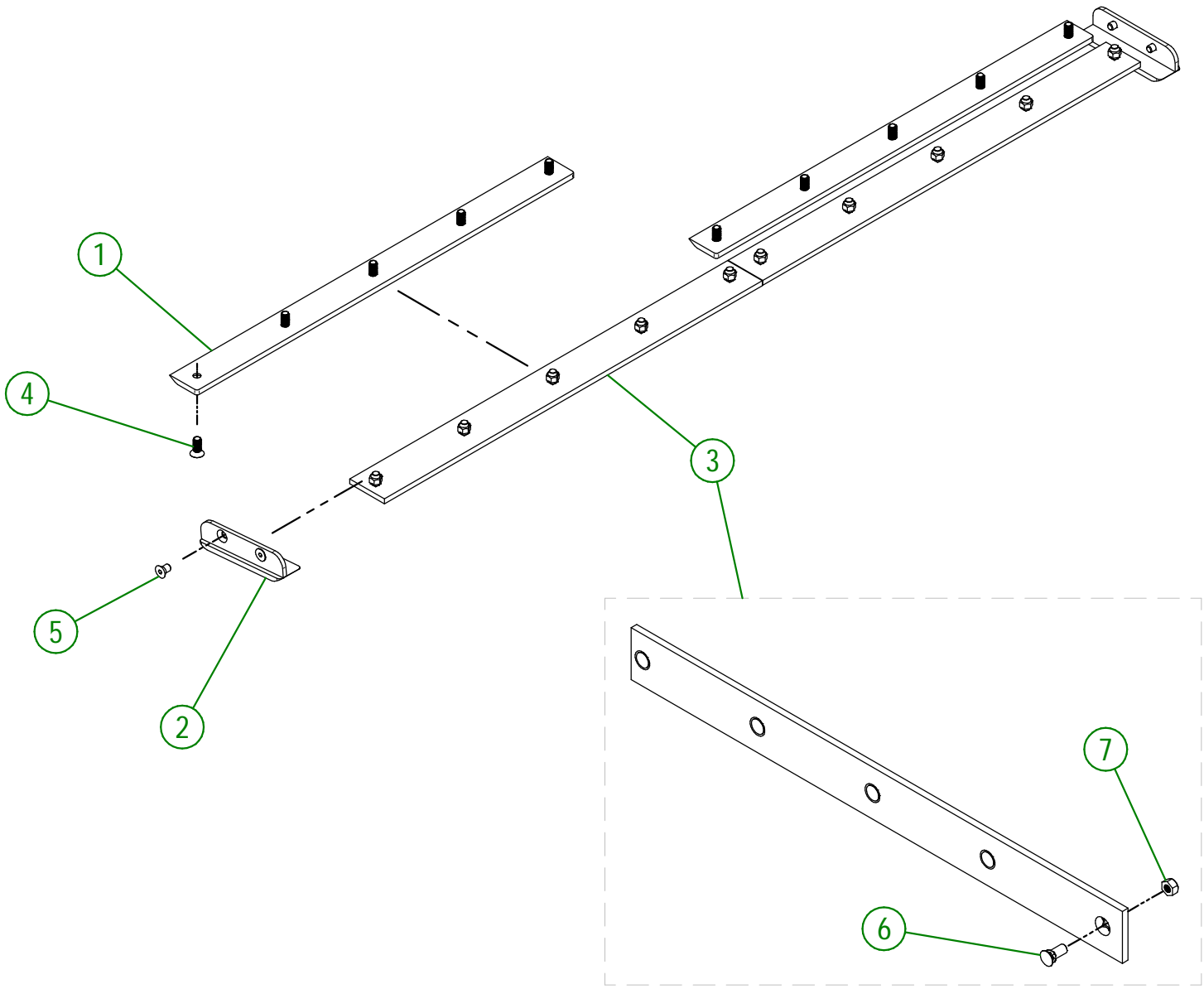

AGRIMETAL	
SET OF KNIVES (#450 HARDNESS STEEL)	
CREATION : 23/08/23	ASSEMBLY : 102-57-0070
REVISION : 12/03/26	AUTHOR : J. Houle

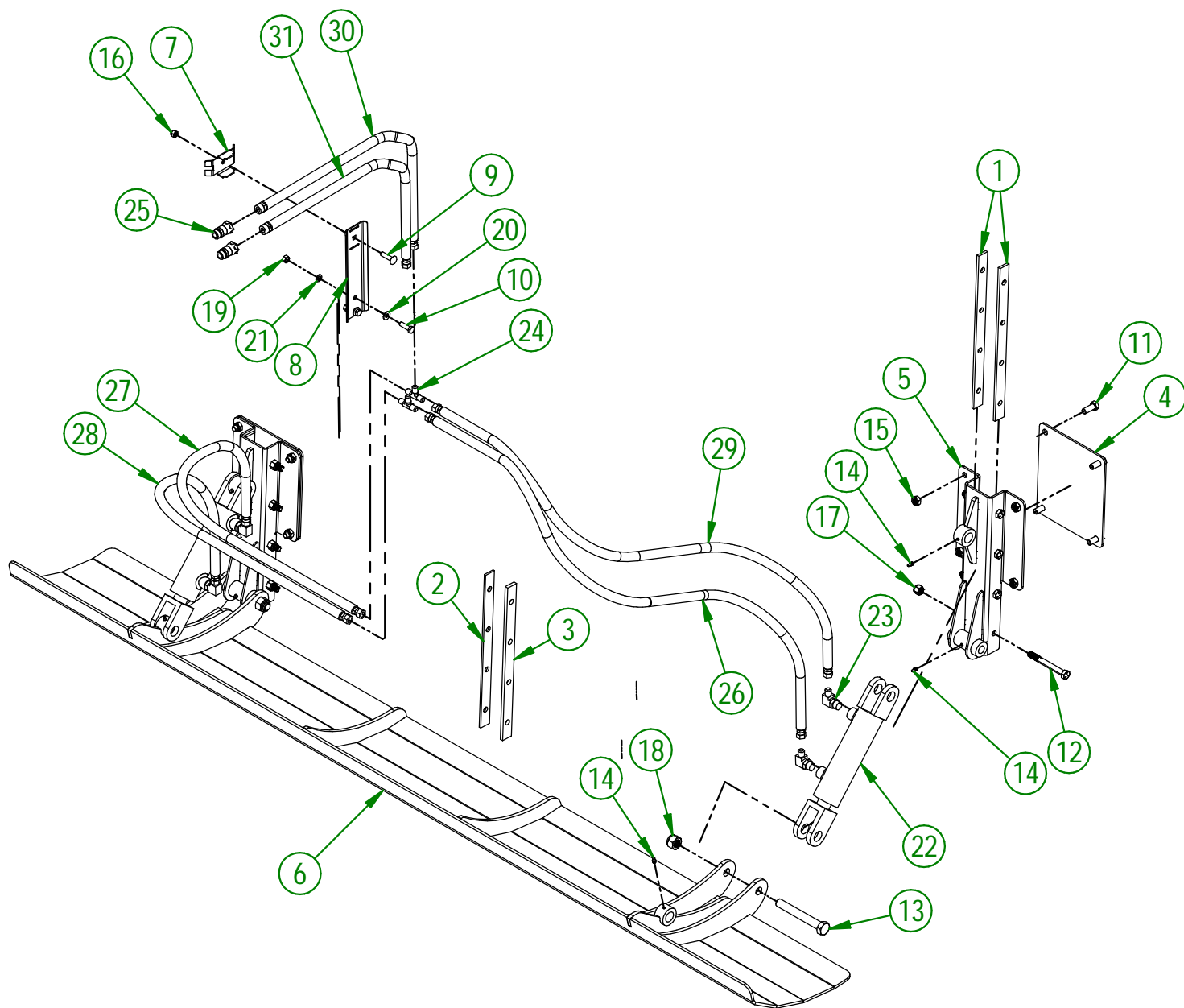

AGRIMETAL

SKI GROUP (HYDRAULIC)

CREATION : 05/03/26
 REVISION : 05/03/26

ASSEMBLY : **104-57-9005**
 AUTHOR : J. Houle

104-57-9005

#	PART #	Qty	TITLE
1	104-04-9030	4	HYDRAULIC CYLINDER SUPPORT REINFORCEMENT
2	104-04-9032	1	HYDRAULIC CYLINDER SUPPORT REINFORCEMENT
3	104-04-9033	1	HYDRAULIC CYLINDER SUPPORT REINFORCEMENT
4	104-04-9035	2	HYDRAULIC CYLINDER SUPPORT REINFORCEMENT
5	104-50-9015	2	ADJUSTABLE HYDRAULIC SKI CYLINDER SUPPORT
6	104-50-9020	1	ADJUSTABLE SKI
7	48-01-7526	1	HYDRAULIC HOSE SUPPORT
8	81-01-7600	1	HYDRAULIC HOSE SUPPORT
9	NC01-07-0111	1	CARR. BOLT GR5 ZINC 3/8-16 X 1 1/2"
10	NC01-25-0115	2	HEX. BOLT GR5 ZINC 3/8-16 X 1 1/4"
11	NC01-25-0248	8	HEX. BOLT GR5 ZINC 1/2-13 X 1 1/4"
12	NC01-25-0261	8	HEX. BOLT GR5 NC ZINC 1/2-13 X 4 1/2"
13	NC01-33-0481	2	HEX. BOLT GR8 ZINC 3/4-10 X 5 1/2"
14	NC01-69-0785	6	STRAIGHT GREASE FITTING 1/4-28
15	NC01-93-0014	8	LOCK NUT ZINC 1/2-13
16	NC01-96-0011	1	NYLON NUT 3/8-16
17	NC01-96-0014	8	NYLON-INSERT LOCKNUT ZINC 1/2-13
18	NC01-96-0017	2	HEX. LOCK NUT NYLO. NC 3/4-10
19	NC02-07-0018	2	HEX. NUT ZINC 3/8-16
20	NC02-25-0009	2	FLAT WASHER 14 GA X 13/16"OD X 25/64" ID
21	NC02-32-0012	2	LOCK WASHER ZINC 3/8"
22	NC13-45-0217	2	HYDRAULIC CYLINDER 4" STROKE
23	NC13-45-0242	4	90 DEG ELBOW
24	NC13-45-0289	2	T 3/8 MALE JIC X 3/8 MALE JIC X 3/8 MALE JIC
25	NC13-45-0369	2	QUICK COUPLER 1/2-14 NPTF
26	NC17-02-0354	1	3/8 X 57" HYDRAULIC HOSE
27	NC17-02-0354	1	3/8 X 60" HYDRAULIC HOSE
28	NC17-02-0354	1	3/8 X 60" HYDRAULIC HOSE
29	NC17-02-0354	1	3/8 X 57" HYDRAULIC HOSE
30	NC17-02-0410	1	3/8 X 63" HYDRAULIC HOSE
31	NC17-02-0410	1	3/8 X 63" HYDRAULIC HOSE

104-57-0507

#	PART #	Qty	TITLE
1	104-01-0070	1	SPRING GUIDE OBSTRUCTIVE PLATE
2	104-57-0500	1	FRAME
3	22-04-6805	4	FLAT WASHER BEARING BASE
4	48-20-0060	1	3 POINT PIN
5	48-20-0065	2	3 POINT PIN
6	80-01-1075	1	SNOW GUARD BRACE
7	81-50-0090	1	STAND
8	81-50-5040	2	ATTACHMENT HAND
9	81-57-0250	1	RUBBER REINFORCEMENT
10	NC01-07-0110	2	CARR. BOLT GR5 ZINC 3/8-16 X 1 1/4"
11	NC01-25-0061	7	HEX BOLT ZINC 5/6-18 X 1 1/4"
12	NC01-25-0396	6	HEX. BOLT GR5 ZINC FULL TREAD 5/8-11 X 2" LG
13	NC01-33-0481	4	HEX. BOLT GR8 ZINC 3/4-10 X 5 1/2"
14	NC01-63-0026	1	COTTER PIN ZC 5/32" X 3"
15	NC01-69-0785	2	STRAIGHT GREASE FITTING 1/4-28
16	NC01-69-1100	3	LINCH PIN 3/8"
17	NC01-69-1306	1	LOCKING PIN 3/8" X 2 1/2" LG
18	NC01-78-0041	6	POP RIVET STAINLESS STEEL ROD STEEL .187" X .690"
19	NC01-93-0017	4	HEX. LOCKNUT STEEL NC Z 3/4-10
20	NC02-07-0018	2	HEX. NUT ZINC 3/8-16
21	NC02-07-0022	6	HEX. NUT ZINC 5/8-11
22	NC02-32-0011	7	LOCK WASHER ZINC 5/16"
23	NC02-32-0012	2	LOCK WASHER ZINC 3/8"
24	NC13-15-0300	1	SNOW GUARD
25	NC13-15-0326	1	RUBBER

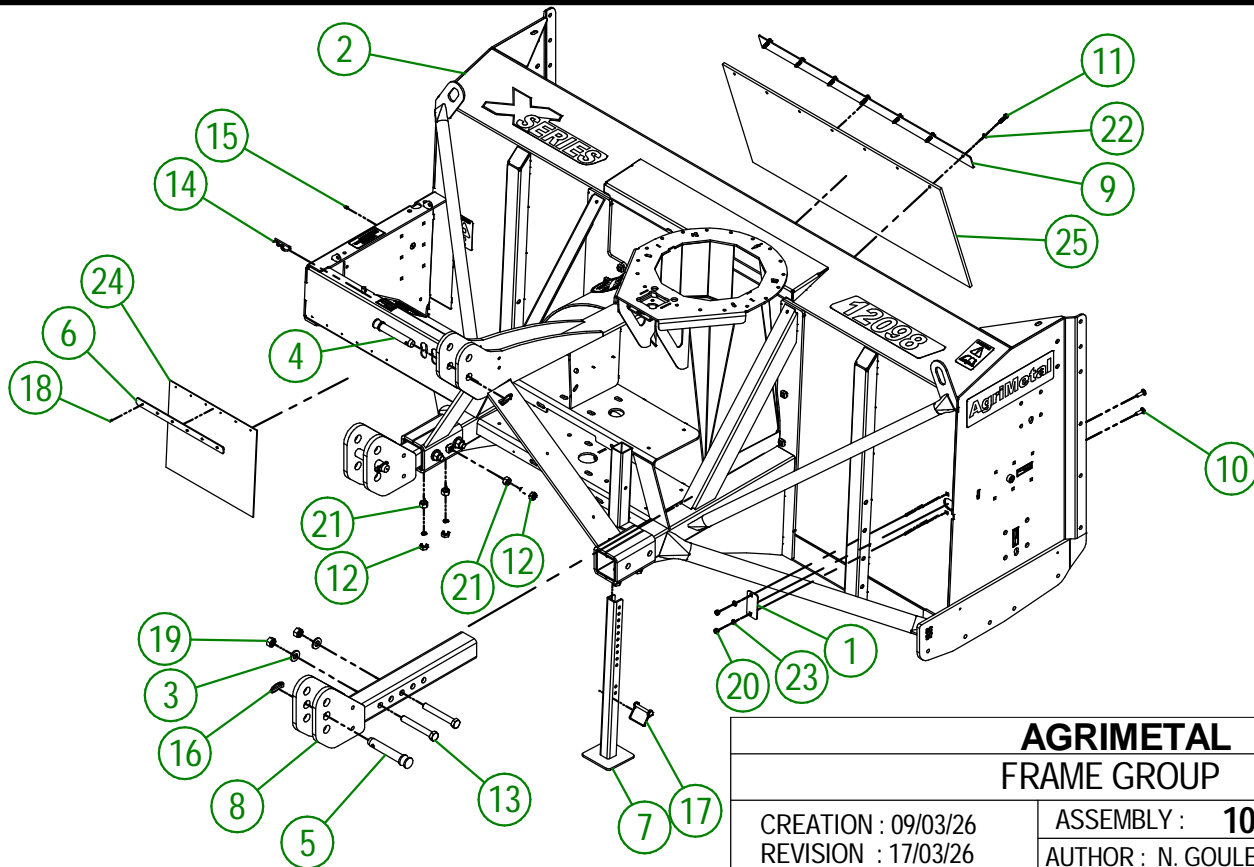

**AGRIMETAL
FRAME GROUP**

CREATION : 09/03/26
REVISION : 17/03/26

ASSEMBLY : **104-57-0507**
AUTHOR : N. GOULET

#	PART #	Qty	TITLE
1	80-04-0480	1	GEARBOX BRACE
2	80-04-0485	1	GEARBOX BRACE
3	80-41-0135	1	PTO GUARD STEEL CABLE
4	81-57-0040	1	PTO GUARD
5	83-01-0170	1	PTO GUARD SUPPORT
6	83-21-0000	4	TRANSMISSION BUSHING
7	83-34-0035	1	PTO SHAFT V90
8	83-41-0900	1	IMPELLER KEY
9	83-55-0010	1	GEAR BOX ASSY.
10	NC01-33-0249	4	CAP SCREW GR8 NC ZINC 1/2-13 X 1 1/2" LG
11	NC01-33-0394	4	HEX. BOLT GR8 NC ZINC 5/8-11 X 1 1/2" LG.
12	NC01-33-0400	4	CAP SCREW GR8 NC ZINC 5/8-11 X 3" LG
13	NC01-63-0027	1	HAIRPIN COTTER
14	NC01-64-0005	2	OVAL SLEEVE (ALUMINUM)
15	NC02-07-0020	4	HEX. NUT ZINC 1/2-13
16	NC02-22-0012	2	WASHER ZINC 1/2 BOLT = 9/16"Ø X 1 3/8" OD
17	NC02-22-0013	6	WASHER ZINC 5/8 ID X 1 1/2 OD
18	NC02-25-0011	8	WASHER SAE ZINC 17/32 ID
19	NC02-32-0014	4	LOCK WASHER ZINC 1/2"
20	NC02-32-0016	8	LOCK WASHER ZINC 5/8"
21	1	BLACK TIE RAP	
22	NC13-50-0110	1	IMPORTANT/NOTICE PTO POSTER

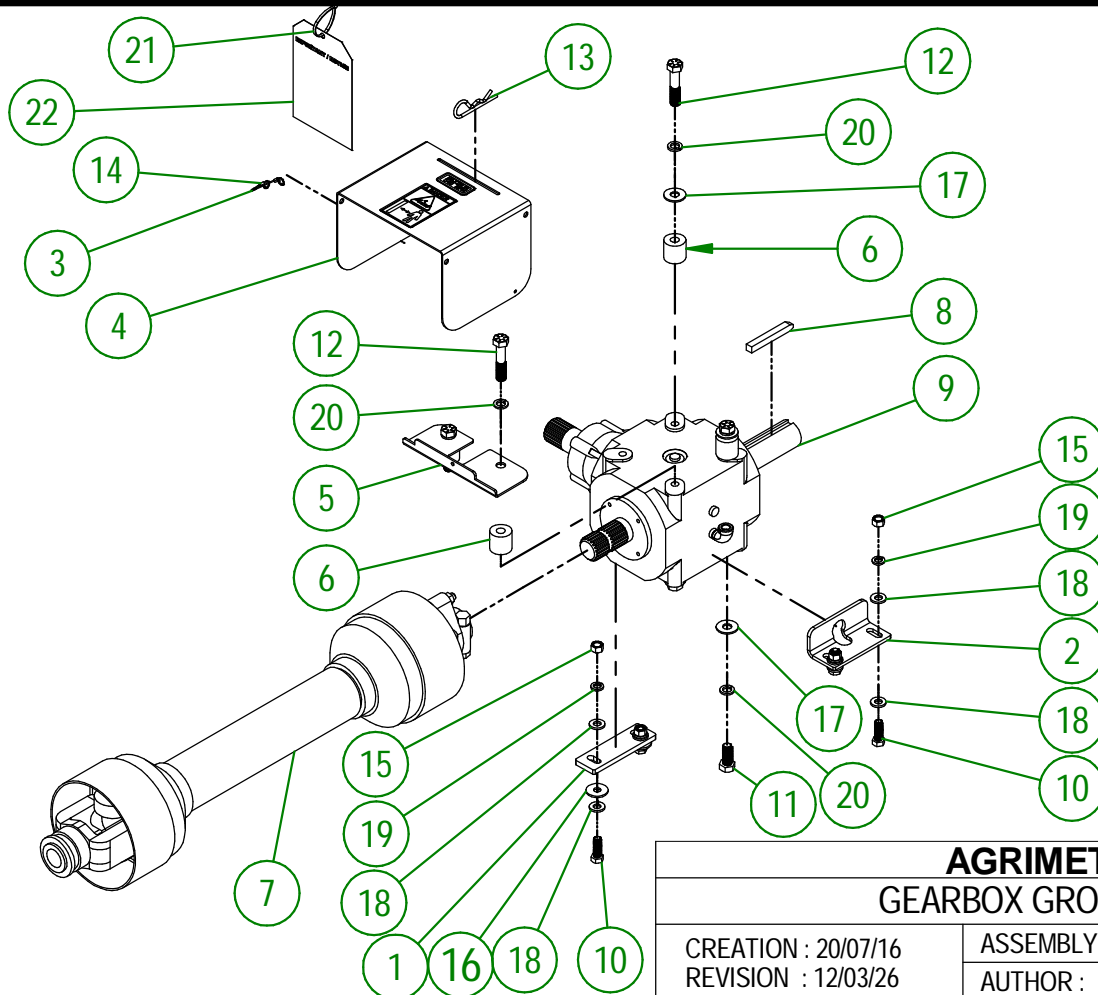

AGRIMETAL
GEARBOX GROUPING

CREATION : 20/07/16
REVISION : 12/03/26

ASSEMBLY : **83-57-0430**
AUTHOR : Dessin2

104-57-0050

#	PART #	Qty	TITLE
1	104-50-0040	1	IMPELLER
2	80-04-0185	1	WASHER
3	NC01-25-0395	1	HEX. BOLT GR5 ZINC 5/8-11 X 1 3/4" LG
4	NC01-37-0259	2	HEX. BOLT GR8 NF ZINC 1/2-20 X 4" LG
5	NC01-94-0013	2	NYLON NUT ZINC 1/2-20"
6	NC02-32-0016	1	LOCK WASHER ZINC 5/8"

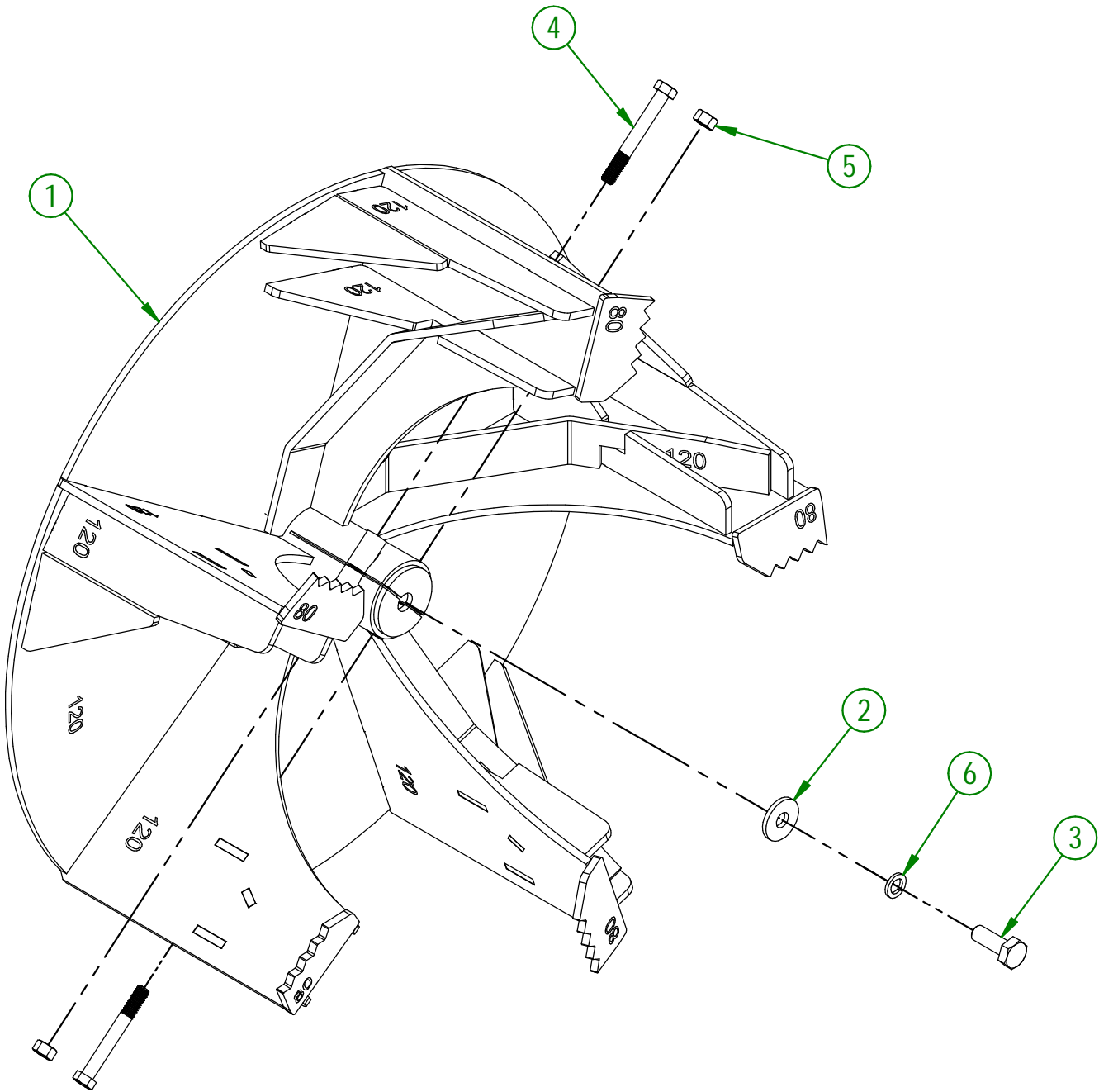

AGRIMETAL	
IMPELLER GROUP	
CREATION : 09/03/26	ASSEMBLY : 104-57-0050
REVISION : 09/03/26	AUTHOR : N. GOULET

104-57-0045

#	PART #	Qty	TITLE
1	104-50-0030	1	LEFT SNOW GUARD
2	104-50-0035	1	RIGHT SNOW GUARD
3	NC01-25-0249	6	HEX. BOLT GR5 ZINC 1/2-13 X 1 1/2" LG
4	NC02-32-0014	6	LOCK WASHER ZINC 1/2"

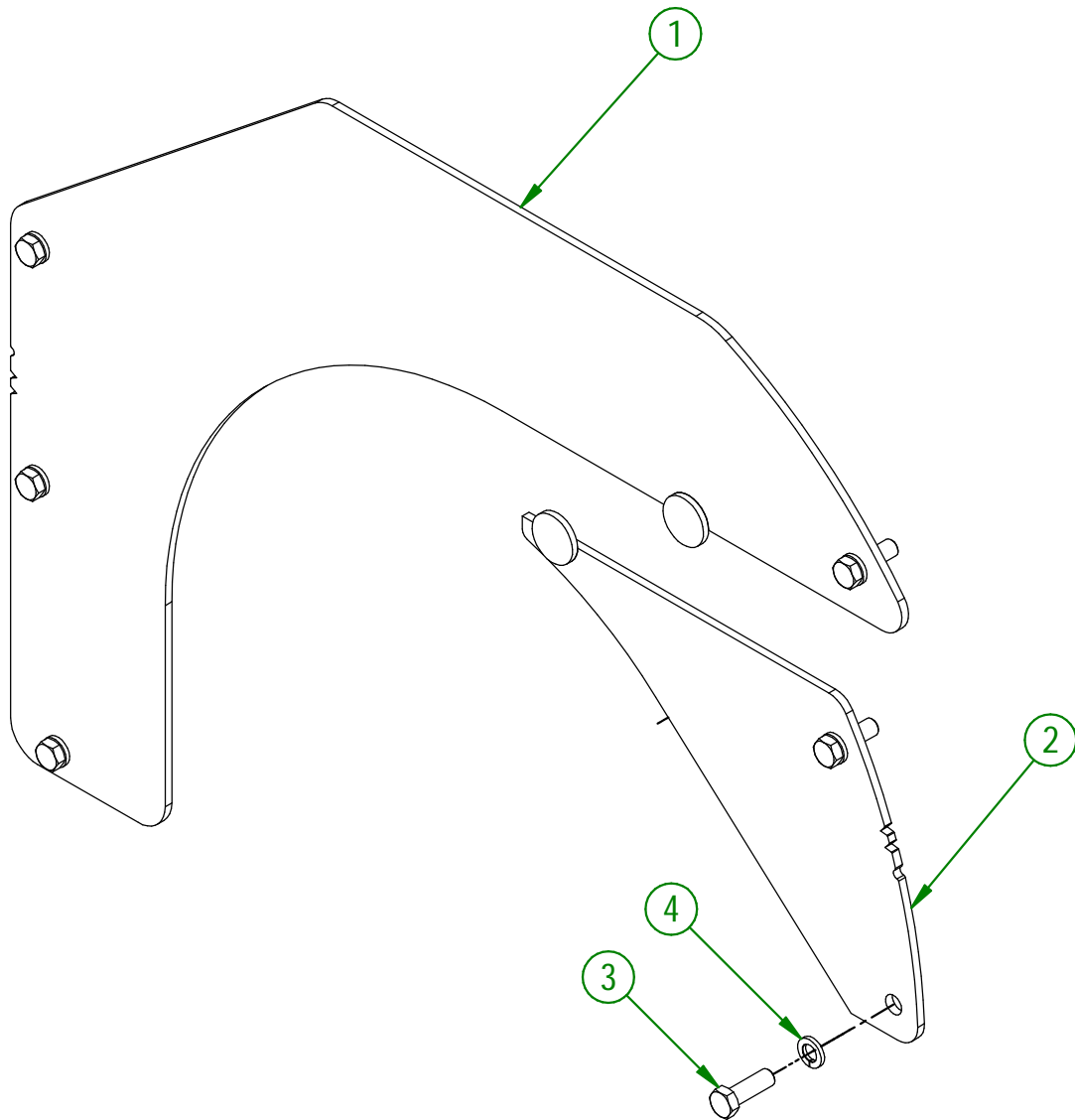

AGRIMETAL	
REGROUPEMENT GARDE-NEIGE	
CREATION : 09/03/26	ASSEMBLY : 104-57-0045
REVISION : 09/03/26	AUTHOR : N. GOULET

83-57-0050

#	PART #	Qty	TITLE
1	83-57-0055	1	PTO GUARD "INCL. STICKER"
2	NC01-33-0249	2	CAP SCREW GR8 NC ZINC 1/2-13 X 1 1/2" LG
3	NC02-22-0012	2	WASHER ZINC 1/2 BOLT = 9/16"Ø X 1 3/8" OD
4	NC01-37-0267	2	HEX. BOLT GR8 ZINC 1/2-20 X 6" LG
5	NC01-94-0013	6	NYLON NUT ZINC 1/2-20"
6	NC01-37-0265	4	HEX. BOLT GR8 ZINC 1/2-20 X 5 1/2" LG
7	NC01-93-0014	2	LOCK NUT ZINC 1/2-13
8	NC01-63-0027	1	HAIRPIN COTTER
9	83-50-0125	1	GEARBOX REDUCER SUPPORT
10	NC02-25-0011	10	WASHER SAE ZINC 17/32 ID
11	NC01-25-0251	2	HEX.BOLT GR5 NC ZINC 1/2-13 X 2"
12	NC02-32-0014	2	LOCK WASHER ZINC 1/2"
13	NC02-07-0020	2	HEX. NUT ZINC 1/2-13
14	83-55-0100	1	SPEED REDUCER 1000 TO 540 RPM

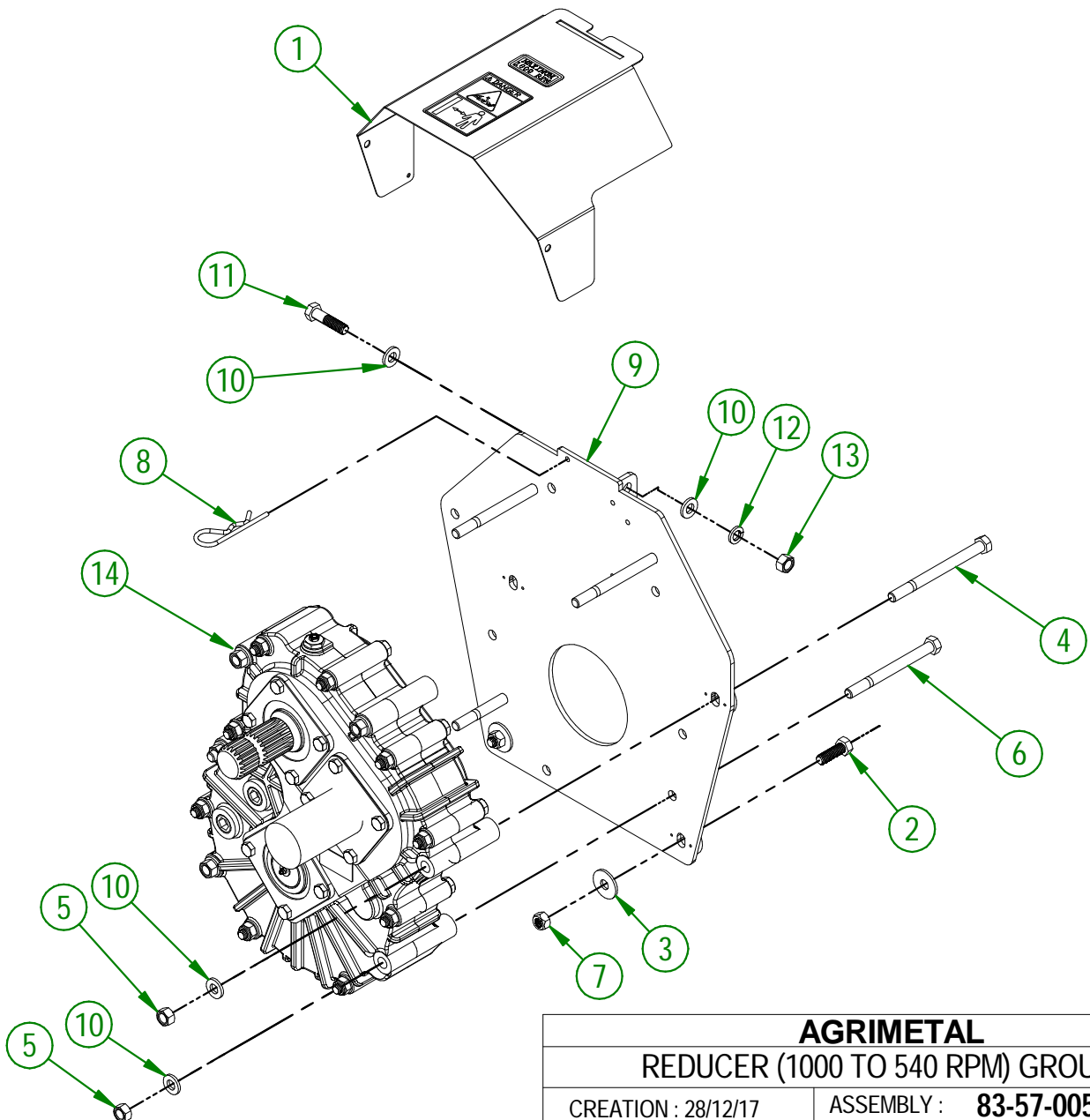

AGRIMETAL	
REDUCER (1000 TO 540 RPM) GROUP	
CREATION : 28/12/17	ASSEMBLY : 83-57-0050
REVISION : 02/07/25	AUTHOR : F.HÉLIE

104-57-0510

#	PART #	Qty	TITLE
1	102-04-0180	1	CHAIN TENSIONER HOLD DOWN PLATE
2	102-04-0365	1	WEAR STRIP HOLDER
3	102-21-0015	1	CHAIN TENSIONER BUSHING
4	102-42-0010	1	SLIDING CHAIN STRIP
5	102-50-1065	1	SPRING GUIDE
6	104-37-0000	1	#80 CHAIN
7	81-01-0927	1	SUPPORT FOR CHAIN TENSIONER
8	81-01-0928	1	SUPPORT FOR CHAIN TENSIONER
9	81-04-0010	1	BEARING SUPPORT
10	81-21-0010	1	SPIRAL DRIVE TRAIN BUSHING
11	81-50-0078	1	SUPPORT FOR CHAIN TENSIONER
12	81-55-0005	1	CHAIN TENSIONER SPROCKET
13	83-50-5566	1	SPIRAL DRIVE TRAIN
14	NC01-07-0110	6	CARR. BOLT GR5 ZINC 3/8-16 X 1 1/4"
15	NC01-25-0114	11	HEX. BOLT GR5 ZINC 3/8-16 X 1"
16	NC01-25-0115	2	HEX. BOLT GR5 ZINC 3/8-16 X 1 1/4"
17	NC01-25-0116	1	HEX. BOLT GR5 ZINC 3/8-16 X 1 1/2"
18	NC01-25-0395	4	HEX. BOLT GR5 ZINC 5/8-11 X 1 3/4" LG
19	NC01-29-0400	1	HEX. BOLT GR5 ZINC 5/8-18 X 3"
20	NC01-69-0785	2	STRAIGHT GREASE FITTING 1/4-28
21	NC01-93-0010	4	LOCK NUT ZINC 5/16-18
22	NC01-93-0011	1	LOCK NUT 3/8-16
23	NC02-07-0018	17	HEX. NUT ZINC 3/8-16
24	NC02-07-0020	2	HEX. NUT ZINC 1/2-13
25	NC02-07-0022	4	HEX. NUT ZINC 5/8-11
26	NC02-10-0022	1	HEX. NUT ZINC 5/8-18
27	NC02-22-0010	6	WASHER 13/32" ID
28	NC02-22-0013	1	WASHER ZINC 5/8 ID X 1 1/2 OD
29	NC02-26-1525	11	WASHER INOX .406" D.I. X .815" D.E.
30	NC02-32-0012	19	LOCK WASHER ZINC 3/8"
31	NC02-32-0016	5	LOCK WASHER ZINC 5/8"
32	NC02-48-0021	4	FLAT HEAD SOCKET CAP SCREW 5/16-18 X 1"
33	NC13-86-0369	1	GREEN SPRING 1/2" ID X 1" OD X 8" LG
34	NC14-55-0328	1	SPROCKET
35	NC14-75-0025	1	FLANGE BEARING 4 HOLES UCF 208-24 X 1 1/2"

104-57-0055

#	PART #	Qty	TITLE
1	104-57-0060	1	CHAIN GUARD
2	NC01-17-0114	2	HEX. BOLT GR2 ZINC 3/8-16 X 1"
3	NC01-96-0011	2	NYLON NUT 3/8-16
4	NC02-26-1525	4	WASHER INOX .406" D.I. X .815" D.E.

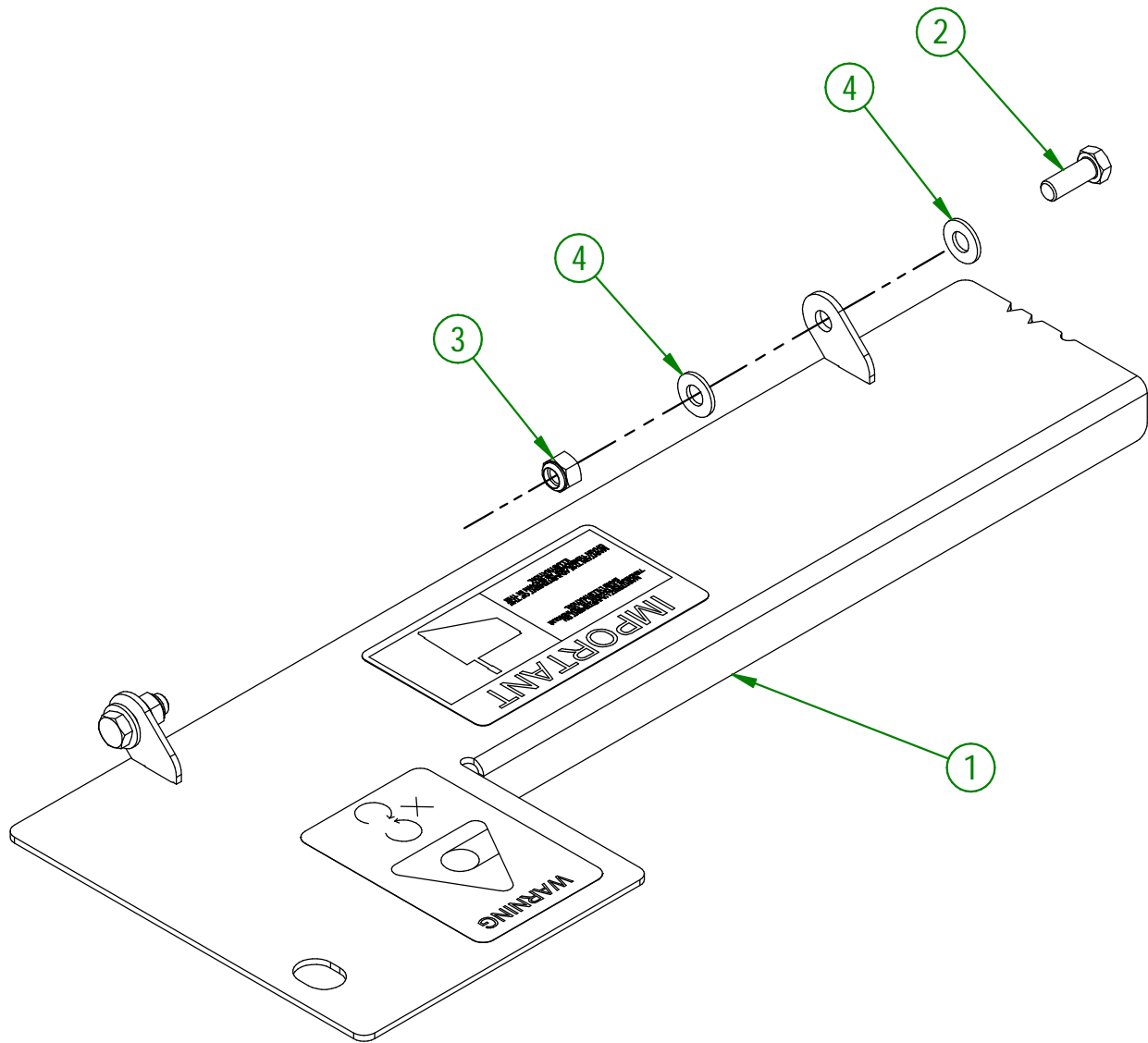

AGRIMETAL	
CHAIN GUARD GROUP	
CREATION : 09/03/26	ASSEMBLY : 104-57-0055
REVISION : 09/03/26	AUTHOR : N. GOULET

#	PART #	Qty	TITLE
1	104-50-0520	1	SPIRAL
2	NC01-17-0396	8	HEX. BOLT GR2 ZINC 5/8-11 X 2"
3	NC02-07-0022	8	HEX. NUT ZINC 5/8-11
4	NC02-25-0013	8	WASHER ZINC SAE ZINC 21/32 ID
5	NC02-32-0016	8	LOCK WASHER ZINC 5/8"
6	NC14-75-0161	2	FLANGE BEARING UCF 208-24 1 1/2" ID
7	NC14-55-0275	1	PIGNON AC. 80A34 X 1 1/2"
8	NC01-37-0249	4	BOULON HEX. GR8 NF ZINC 1/2-20 X 1 1/2"
9	NC01-94-0013	4	ÉCROU HEX. BLOC AC. NC ZINC 1/2-20
10	102-51-1070	1	SHAFT OF THE SPIRAL
11	102-51-1075	1	SHAFT OF THE SPIRAL (SPROCKET)

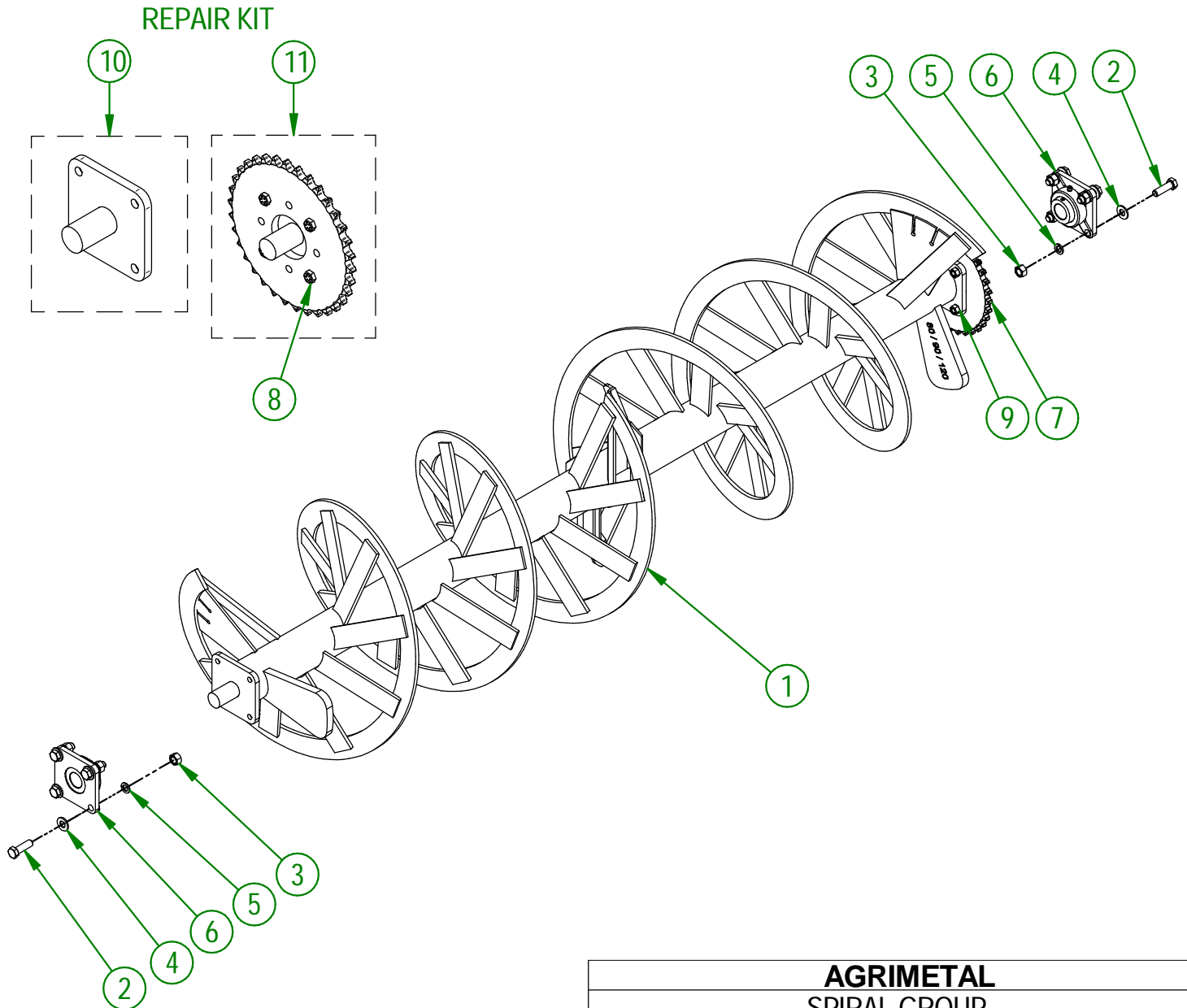

AGRIMETAL
SPIRAL GROUP

CREATION : 09/03/26
REVISION : 30/03/26

ASSEMBLY : **104-57-0520**
AUTHOR : N. GOULET

102-57-1065

#	PART #	Qty	TITLE
1	102-50-1050	1	CHAIN GUARD
2	NC01-07-0109	5	CARR. BOLT GR5 ZINC 3/8-16 X 1"
3	NC02-14-0019	5	FLANGE NUT HEX. NC 3/8-16 GR. B

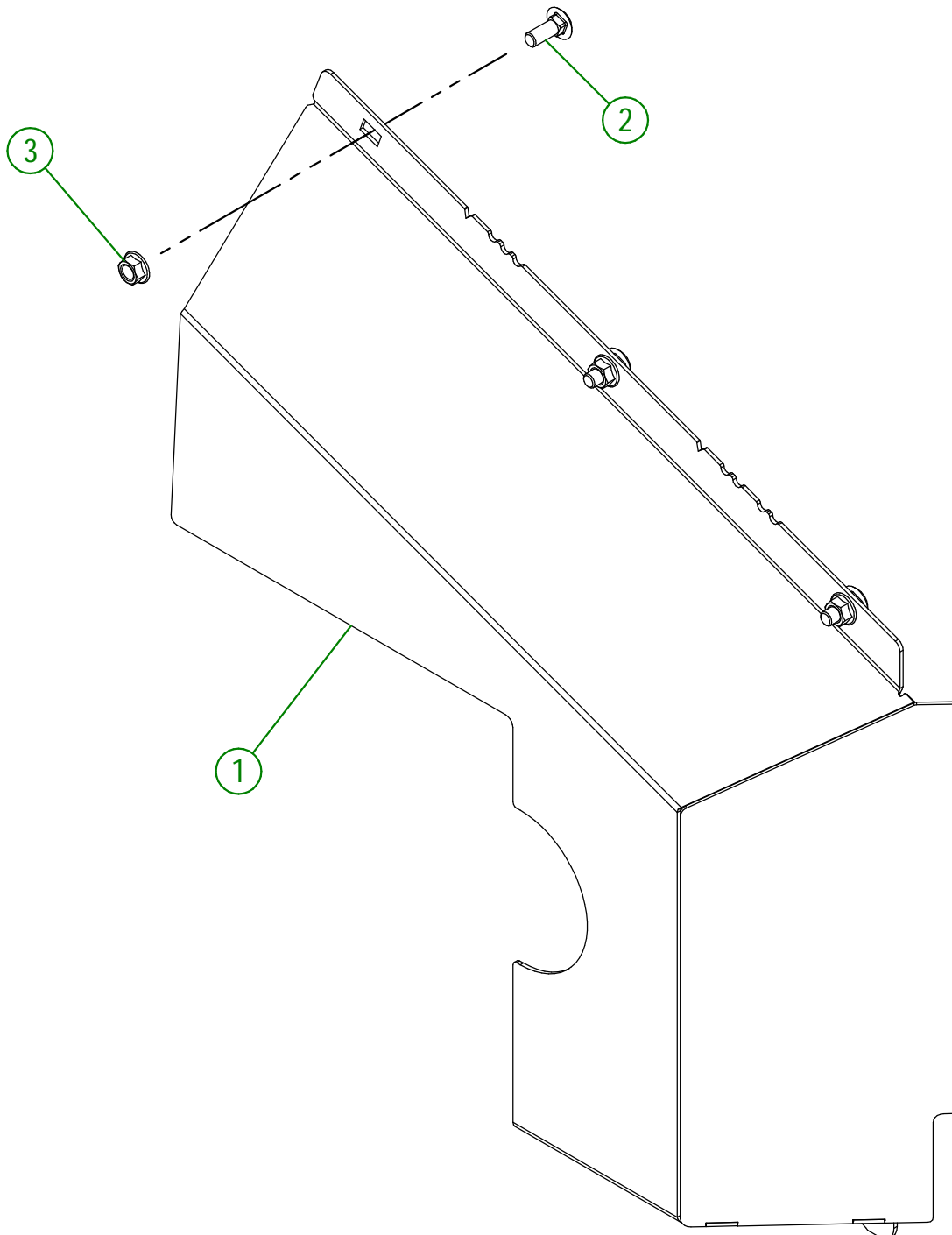

AGRIMETAL	
SPIRAL CHAIN GUARD GROUP	
CREATION : 21/08/23	ASSEMBLY : 102-57-1065
REVISION : 12/03/26	AUTHOR : J. Houle

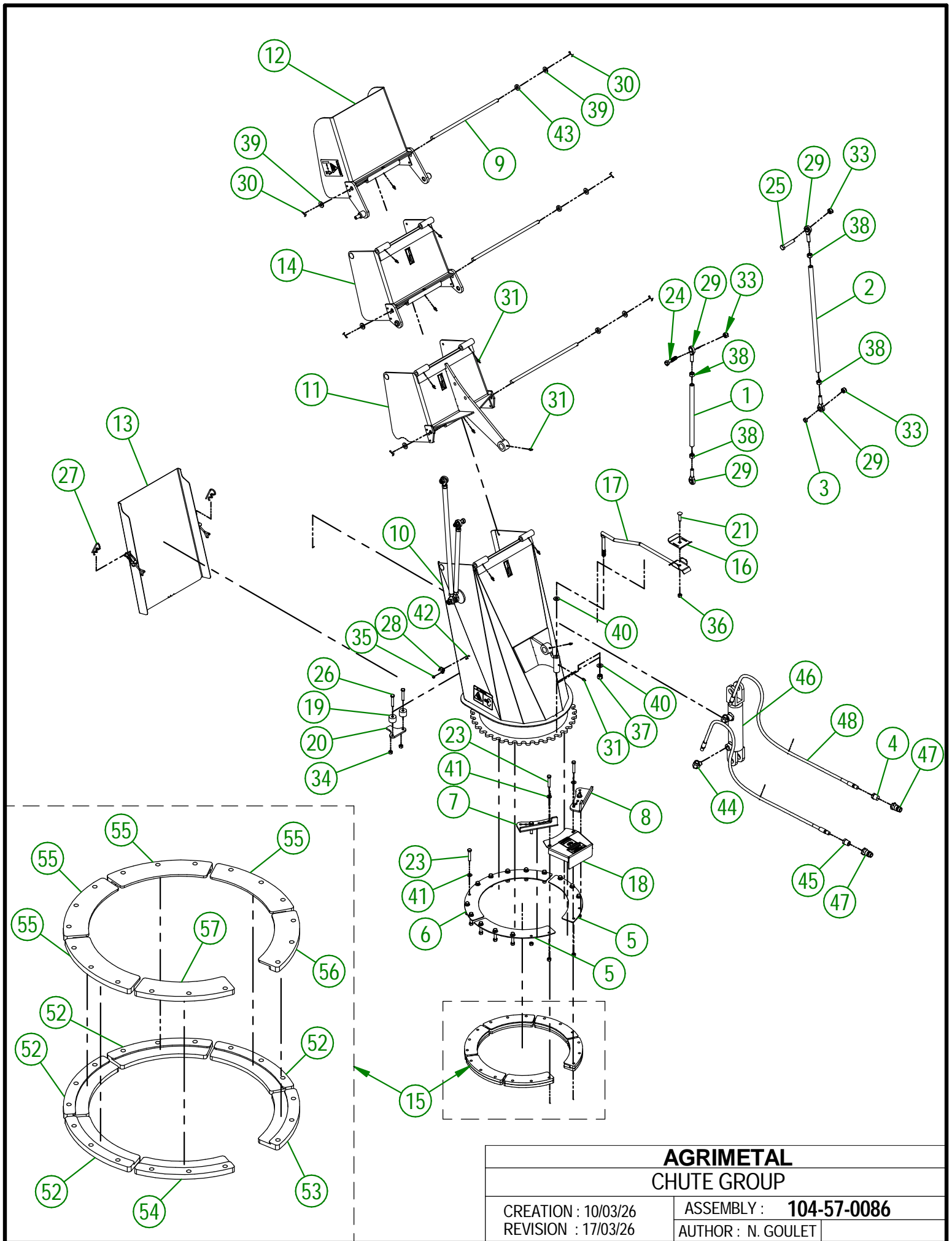

**AGRIMETAL
CHUTE GROUP**

CREATION : 10/03/26
REVISION : 17/03/26

ASSEMBLY : **104-57-0086**
AUTHOR : N. GOULET

104-57-0086

#	PART #	Qty	TITLE
1	103-13-0000	2	CHUTE ROD (TRIPLE)
2	103-13-0005	2	CHUTE ROD (TRIPLE)
3	103-13-0025	2	CHUTE ROD SPACER
4	103-25-0000	1	1/2 NPT STRAIGHT UNION X 3/64"
5	104-01-0035	2	BRACE
6	104-01-0040	1	BRACE
7	104-04-0160	1	ADJUSTABLE STOPPER
8	104-04-0165	1	ADJUSTABLE STOPPER
9	104-20-0060	3	PIVOT
10	104-57-0066	1	CHUTE (BOTTOM SECTION)
11	104-57-0071	1	FIRST SECTION "STICKERS INCL."
12	104-57-0076	1	THIRD SECTION "STICKERS INCL."
13	104-57-0081	1	CHUTE DOOR
14	104-57-0090	1	SECOND SECTION "STICKERS INCL."
15	104-57-0200	1	CHUTE GUIDE GROUP
16	48-01-7531	1	HYDRAULIC HOSE SUPPORT
17	48-50-1031	1	HYDRAULIC HOSE SUPPORT
18	80-57-0550	1	SPROCKET GUARD GROUP "STICKER INCLUDED"
19	81-21-0040	2	ADJUSTABLE STOPPER SPACER
20	84-04-0170	1	STOPPER
21	NC01-07-0111	1	CARR. BOLT GR5 ZINC 3/8-16 X 1 1/2"
22	NC01-07-0241	2	CARR. BOLT GR5 ZINC 1/2-13 X 3" LG
23	NC01-17-0118	18	HEX. BOLT GR2 ZINC 3/8-16 X 2"
24	NC01-25-0251	2	HEX.BOLT GR5 NC ZINC 1/2-13 X 2"
25	NC01-25-0253	2	HEX. BOLT GR5 NC ZINC 1/2-13 X 2 1/2"
26	NC01-37-0118	2	HEX. BOLT GR8 ZINC 3/8-24 X 2"
27	NC01-63-0026	2	COTTER PIN ZC 5/32" X 3"
28	NC01-63-0052	2	ADJUSTABLE LATCH (STRIKE)
29	NC01-67-0306	8	1/2-20 ROD END
30	NC01-69-0139	6	COTTER PIN ZINC 1/8" X 3/4"
31	NC01-69-0785	12	STRAIGHT GREASE FITTING 1/4-28
32	NC01-93-0011	18	LOCK NUT 3/8-16
33	NC01-93-0014	6	LOCK NUT ZINC 1/2-13
34	NC01-94-0011	2	LOCK NUT 3/8-24
35	NC01-96-0006	4	NYLON NUT ZINC 3/16
36	NC01-96-0011	1	NYLON NUT 3/8-16
37	NC01-96-0014	1	NYLON-INSERT LOCKNUT ZINC 1/2-13
38	NC02-10-0020	8	HEX. NUT ZINC 1/2-20
39	NC02-25-0011	6	WASHER SAE ZINC 17/32 ID
40	NC02-25-0011	2	WASHER SAE ZINC 17/32 ID
41	NC02-26-1525	18	WASHER INOX .406" D.I. X .815" D.E.
42	NC02-40-0080	4	MACHINE SCREWS SQUARE SOCKET #10-24 X 1/2" LG
43	NC13-15-0334	6	PIVOT WASHER
44	NC13-45-0038	2	ELBOW 90 3/8 FEM. NPT X 3/8 MALE NPT
45	NC13-45-0153	1	HEX. REDUCER 1/4 NPT X 1/2 NPT
46	NC13-45-0217	1	HYDRAULIC CYLINDER 4" STROKE

104-57-0086

#	PART #	Qty	TITLE
47	NC13-45-0369	2	QUICK COUPLER 1/2-14 NPTF
48	NC17-02-0347	2	HYDRAULIC HOSE (111" LG)

104-57-0200

#	PART #	Qty	TITLE
52	104-42-0000	4	CHUTE GUIDE
53	104-42-0005	1	CHUTE GUIDE
54	104-42-0010	1	CHUTE GUIDE
55	104-42-0015	4	CHUTE GUIDE
56	104-42-0020	1	CHUTE GUIDE
57	104-42-0025	1	CHUTE GUIDE

#	PART #	Qty	TITLE
1	48-01-7527	1	HYDRAULIC HOSE SUPPORT
2	48-50-1025	1	HYDRAULIC ENGINE SPROCKET
3	80-13-0100	2	HYDRAULIC RESTRICTOR
4	80-45-0000	2	HEX. REDUCER 1/4 NPT X 1/2 NPT
5	81-01-7600	1	HYDRAULIC HOSE SUPPORT
6	NC01-04-0111	1	CARR. BOLT GR2 ZINC 3/8-16 X 1 1/2"
7	NC01-17-0115	2	HEX. BOLT GR2 ZINC 3/8-16 X 1 1/4"
8	NC01-33-0113	4	HEX.BOLT GR8 ZINC 3/8-16 X 3/4"
9	NC01-45-0184	1	HEX. BOLT GR8.8 ZINC 8MM X 20MM
10	NC01-96-0011	1	NYLON NUT 3/8-16
11	NC02-07-0018	2	HEX. NUT ZINC 3/8-16
12	NC02-26-0504	1	WASHER
13	NC02-26-1525	2	WASHER INOX .406" D.I. X .815" D.E.
14	NC02-32-0011	1	LOCK WASHER ZINC 5/16"
15	NC02-32-0012	6	LOCK WASHER ZINC 3/8"
16	NC02-44-0103	2	SET SCREW 5/16-18 X 3/8"
17	NC13-45-0367	2	45°-7/8-14 MALE O RING X 1/2 FEM.TOUR.NPT PT
18	NC13-45-0369	2	QUICK COUPLER 1/2-14 NPTF
19	NC13-45-0378	2	HYDRAULIC RESTRICTOR BUSHING
20	NC14-45-0156	1	HYDRAULIC MOTOR
21	NC17-02-0406	2	HYDRAULIC HOSE (87" LG)
22	NC17-46-0031	1	HYDRAULIC MOTOR BUSHING

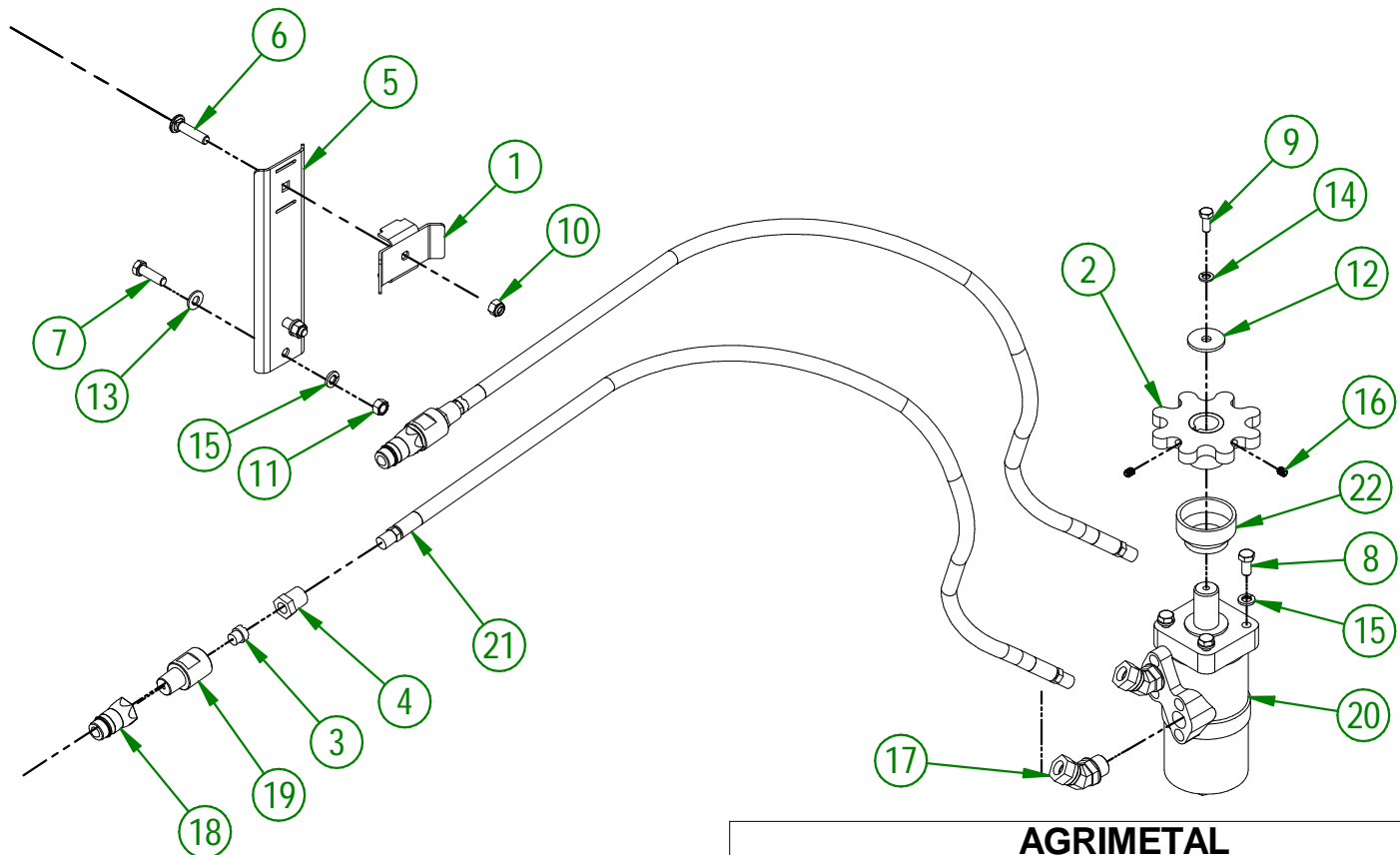

AGRIMETAL
HYDRAULIC MOTOR GROUP

CREATION : 05/12/17
REVISION : 25/03/26

ASSEMBLY : **81-57-5045**
AUTHOR : F.HÉLIE

81-57-0215

#	PART #	Qty	TITLE
1	81-20-0337	1	LATERAL CUTTER BLADES (LEFT)
2	81-20-0335	1	LATERAL CUTTER BLADES (RIGHT)
3	81-10-0000	4	LATERAL CUTTER BLADES BUSHING
4	NC01-33-0248	10	HEX. BOLT .GR8 NC ZINC 1/2-13 X 1 1/4"
5	NC01-33-0514	4	HEX. BOLT GR8 ZINC 1/2-13 X 2 1/4"
6	NC02-32-0014	14	LOCK WASHER ZINC 1/2"
7	NC02-07-0020	14	HEX. NUT ZINC 1/2-13
8	81-04-0525	2	LATERAL KNIFE REINFORCE
9	NC02-22-0012	2	WASHER ZINC 1/2 BOLT = 9/16"Ø X 1 3/8" OD

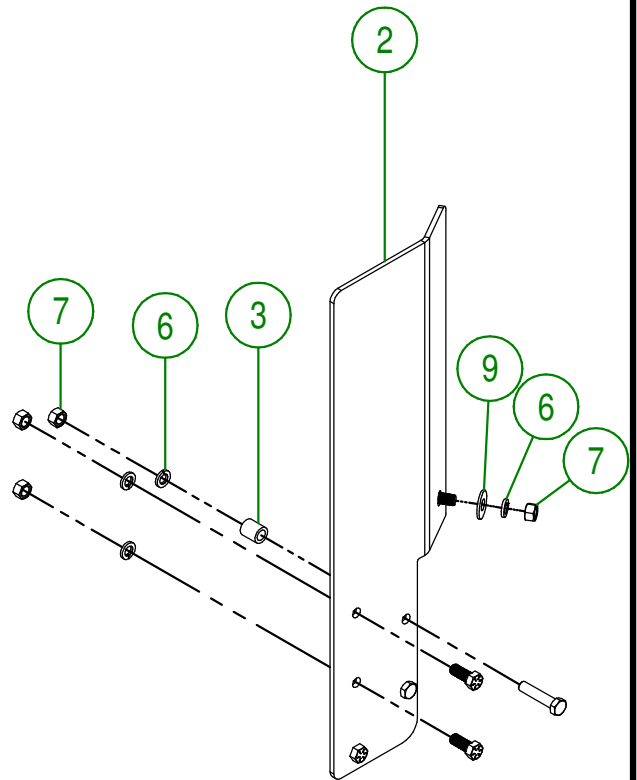
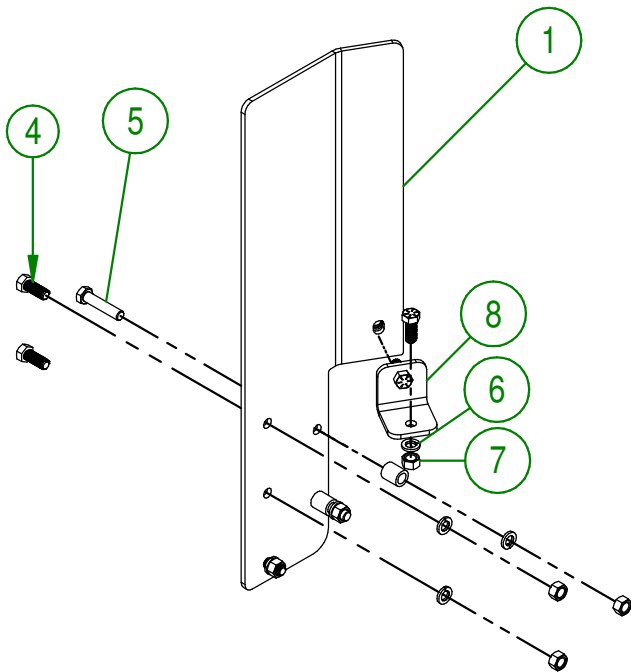

AGRIMETAL	
LATERAL CUTTER BLADES	
CREATION : 24/11/17	ASSEMBLY : 81-57-0215
REVISION : 06/12/21	AUTHOR : J. Houle

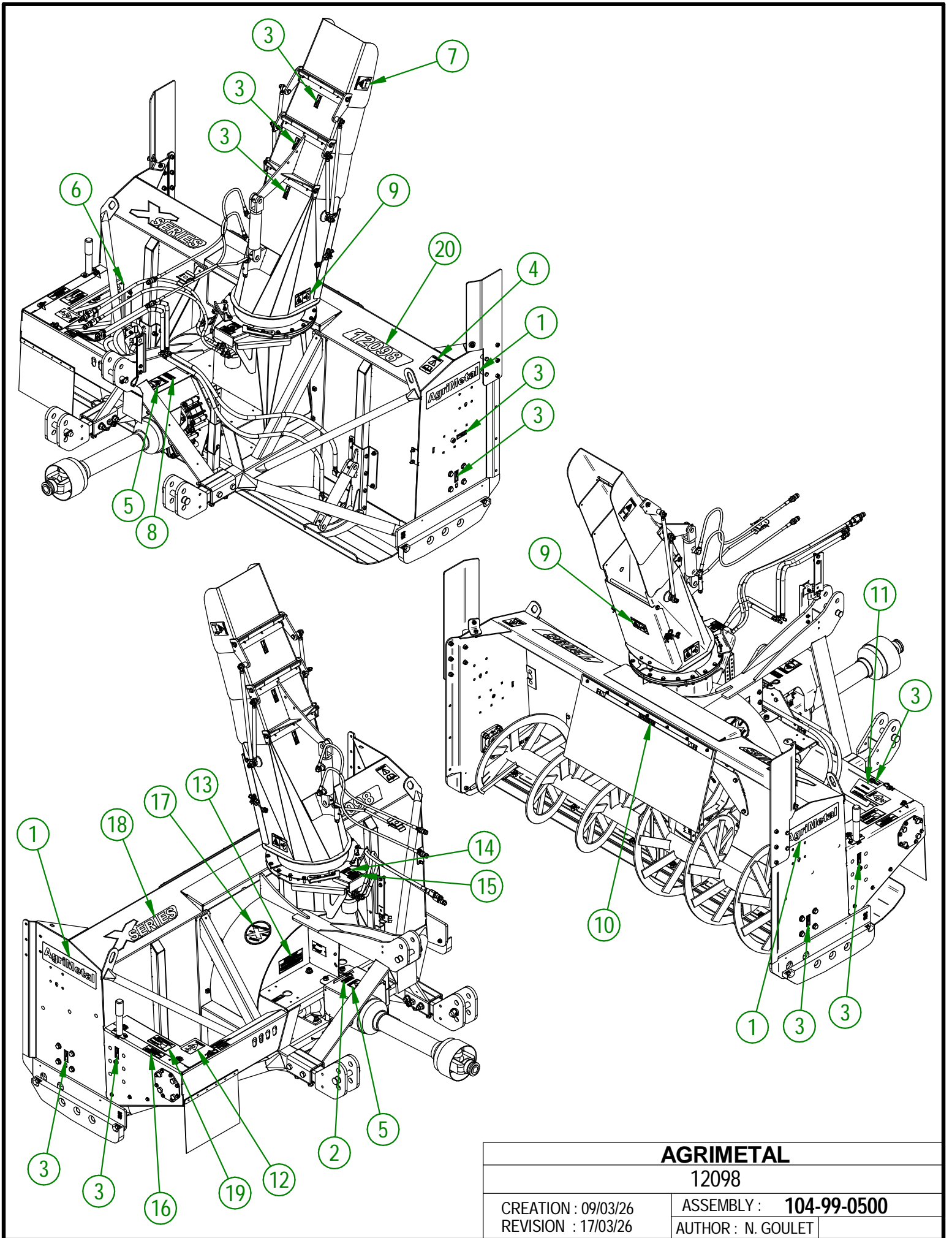

AGRIMETAL

12098

CREATION : 09/03/26
 REVISION : 17/03/26

ASSEMBLY : **104-99-0500**
 AUTHOR : N. GOULET

104-99-0500

#	PART #	Qty	TITLE
1	NC13-33-0001	2	STICKER AGRIMETAL
2	NC13-33-0005	1	STICKER MAXIMUM 540 RPM
3	NC13-33-0024	9	STICKER GREASE HERE
4	NC13-33-0183	1	STICKER CAUTION OPERATION MANUAL
5	NC13-33-0187	2	STICKER DANGER (PTO AND PERSON)
6	NC13-33-0189	1	STICKER DANGER (PERSON AND CHAIN DRIVE)
7	NC13-33-0192	2	STICKER (PROJECTION RISK)
8	NC13-33-0228	1	STICKER MAXIMUM 1000 RPM
9	NC13-33-0249	3	STICKER DANGER
10	NC13-33-0274	2	STICKER DANGER
11	NC13-33-0281	1	STICKER SHEAR BOLT
12	NC13-33-0283	1	STICKER DANGER (PERSON AND CHAIN DRIVE)
13	NC13-33-0317	1	STICKER GREASE DRIVE LINE TELESCOPIC SHAFT
14	NC13-33-0326	1	STICKER DANGER (HAND)
15	NC13-33-0327	1	STICKER END ROTATION ADJUSTMENT
16	NC13-33-0343	1	GREASE CHAIN EVERY 10 HOURS STICKER
17	NC13-33-2669	1	STICKER ANGLE RIGHT
18	NC13-33-2670	1	STICKER X SERIES
19	NC13-33-2676	1	IMPORTANT MAINTAIN THE ADJUSTMENT OF THE CHAIN TENSIONER
20	NC13-33-2677	1	STICKER 9092-X