

# AgriMetal

## PARTS LIST

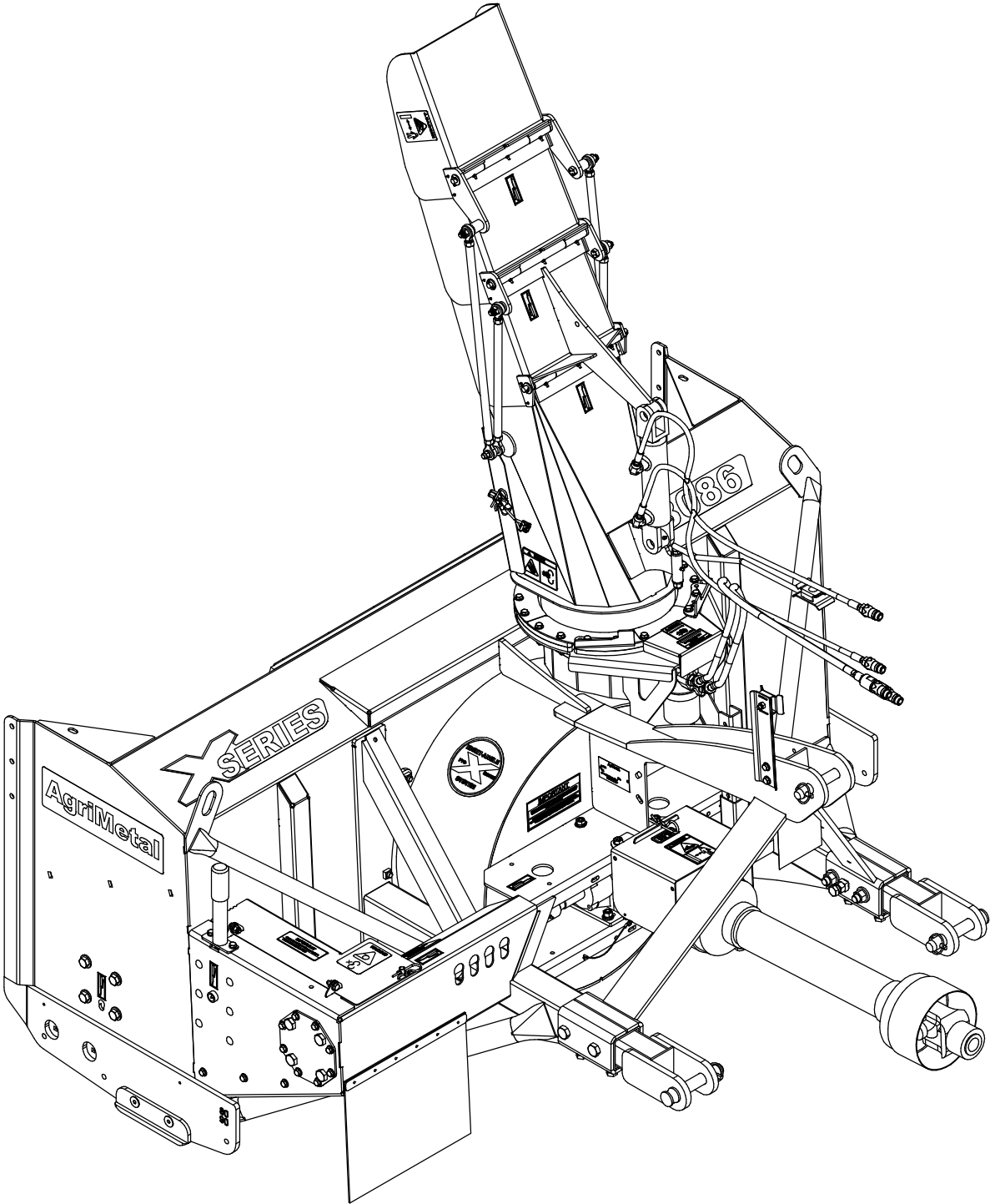

**X-8086**

102-57-0975

#	PART #	Qty	TITLE
1	80-50-0085	2	LATERAL SKATE (#450 HARDNESS STEEL)
2	NC02-48-0586	4	FLAT HEAD SOCKET CAP SCREW 5/8-11 X 1" LG
3	81-57-0220	2	KNIFE (#450 HARDNESS STEEL) GROUP (BOLTS AND NUTS INCLUDED)
4	102-04-0385	2	SKATE (#450 HARDNESS STEEL)
5	NC02-48-0562	10	FLAT HEAD SOCKET CAP SCREW STAINLESS 5/8-11 X 1 1/2"

81-57-0220

#	PART #	QTY	TITLE
6	NC01-09-0039	5	PLOW BOLT GR5 5/8-11 X 1 1/2" LG
7	NC01-93-0016	5	LOCK NUT ZINC 5/8-11

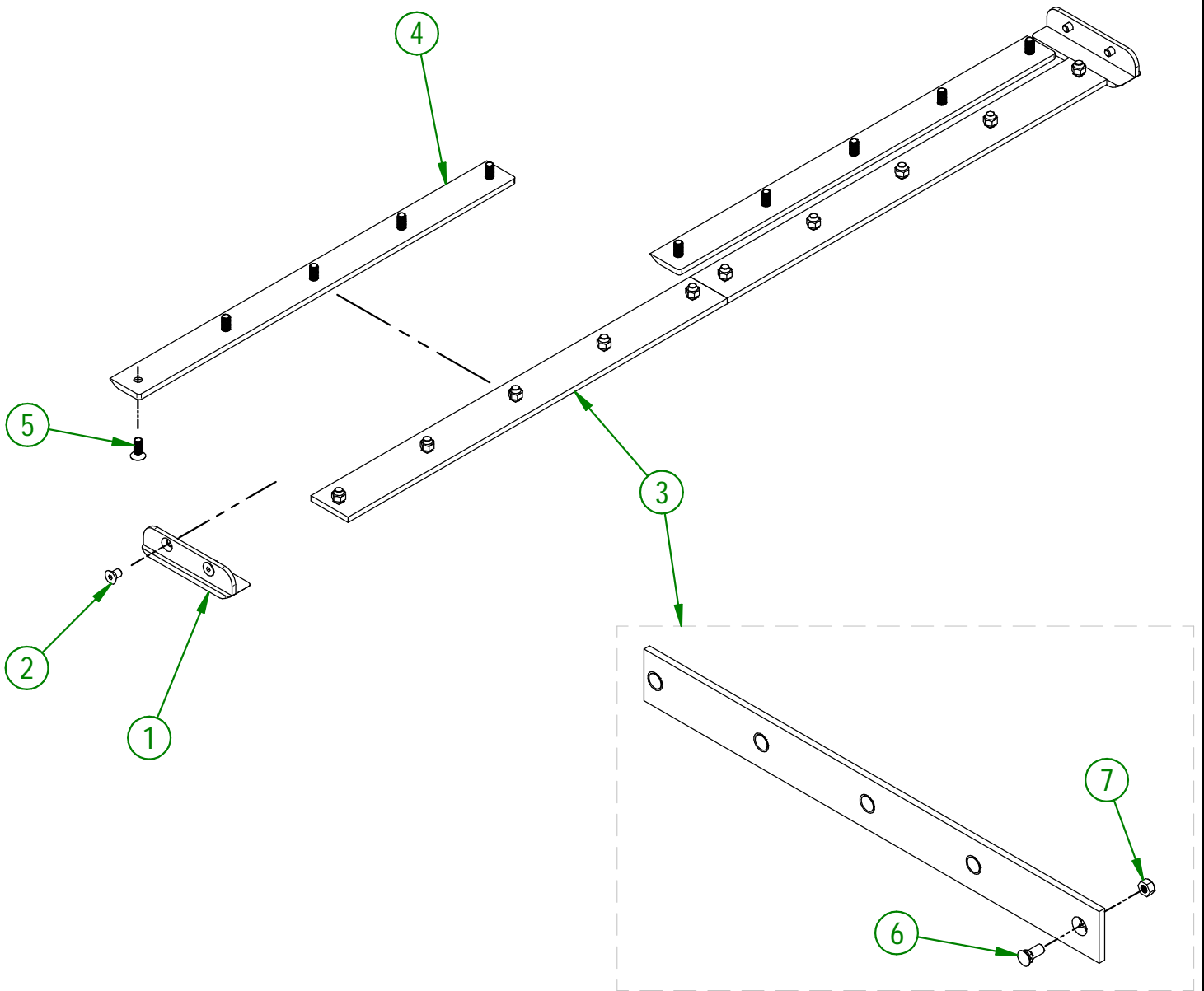

**AGRIMETAL**

SET OF KNIVES (#450 HARDNESS STEEL)

CREATION : 21/08/23  
REVISION : 25/09/23

ASSEMBLY : **102-57-0975**  
AUTHOR : J. Houle

102-57-0980

#	PART #	Qty	TITLE
1	80-50-0087	2	LATERAL SKATE (STAINLESS STEEL)
2	NC02-48-0586	4	FLAT HEAD SOCKET CAP SCREW 5/8-11 X 1"LG
3	81-57-0225	2	KNIFE (STAINLESS STEEL) GROUP (BOLTS AND NUTS INCLUDED)
4	102-20-0175	2	SKATE (STAINLESS STEEL)
5	NC02-48-0562	10	FLAT HEAD SOCKET CAP SCREW STAINLESS 5/8-11 X 1 1/2"

81-57-0225

#	PART #	QTY	TITLE
6	NC01-93-0016	5	LOCK NUT ZINC 5/8-11
7	NC02-48-0562	5	FLAT HEAD SOCKET CAP SCREW STAINLESS 5/8-11 X 1 1/2"

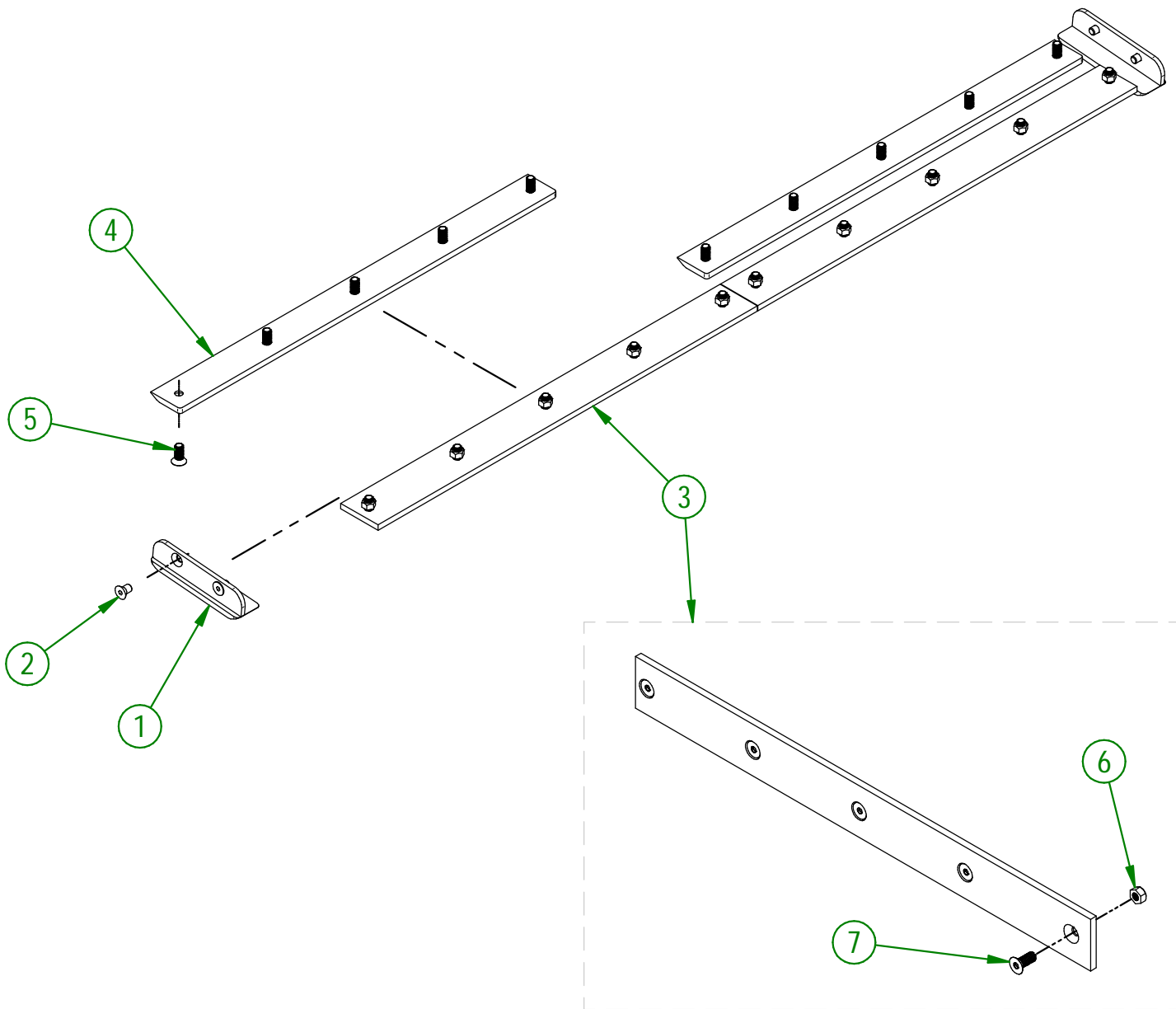

**AGRIMETAL**

**SET OF KNIVES (STAINLESS STEEL)**

CREATION : 21/08/23  
REVISION : 25/09/23

ASSEMBLY : **102-57-0980**  
AUTHOR : J. Houle

#	PART #	Qty	TITLE
1	81-50-0200	2	KNIFE BRACE (TOP)
2	81-42-0100	1	RIGHT KNIFE (UHMW)
3	81-42-0101	1	LEFT KNIFE (UHMW)
4	81-04-0355	2	KNIFE BRACE (UNDER)
5	NC02-48-0564	10	FLAT HEAD SOCKET CAP SCREW STAINLESS 5/8-11 X 2" LG
6	NC01-93-0016	10	LOCK NUT ZINC 5/8-11
7	102-42-0005	1	LATERAL KNIFE (RIGHT)
8	102-42-0000	1	LATERAL KNIFE (LEFT)
9	NC02-25-0011	4	WASHER SAE ZINC 17/32 ID
10	NC02-22-0014	6	WASHER
11	NC01-25-0394	6	HEX BOLT GR5 ZINC 5/8-11 X 1 1/2"
12	NC01-25-0250	2	HEX. BOLT GR5 ZINC 1/2-13 X 1 3/4"
13	NC01-25-0251	2	HEX.BOLT GR5 NC ZINC 1/2-13 X 2"
14	NC01-93-0014	4	LOCK NUT ZINC 1/2-13

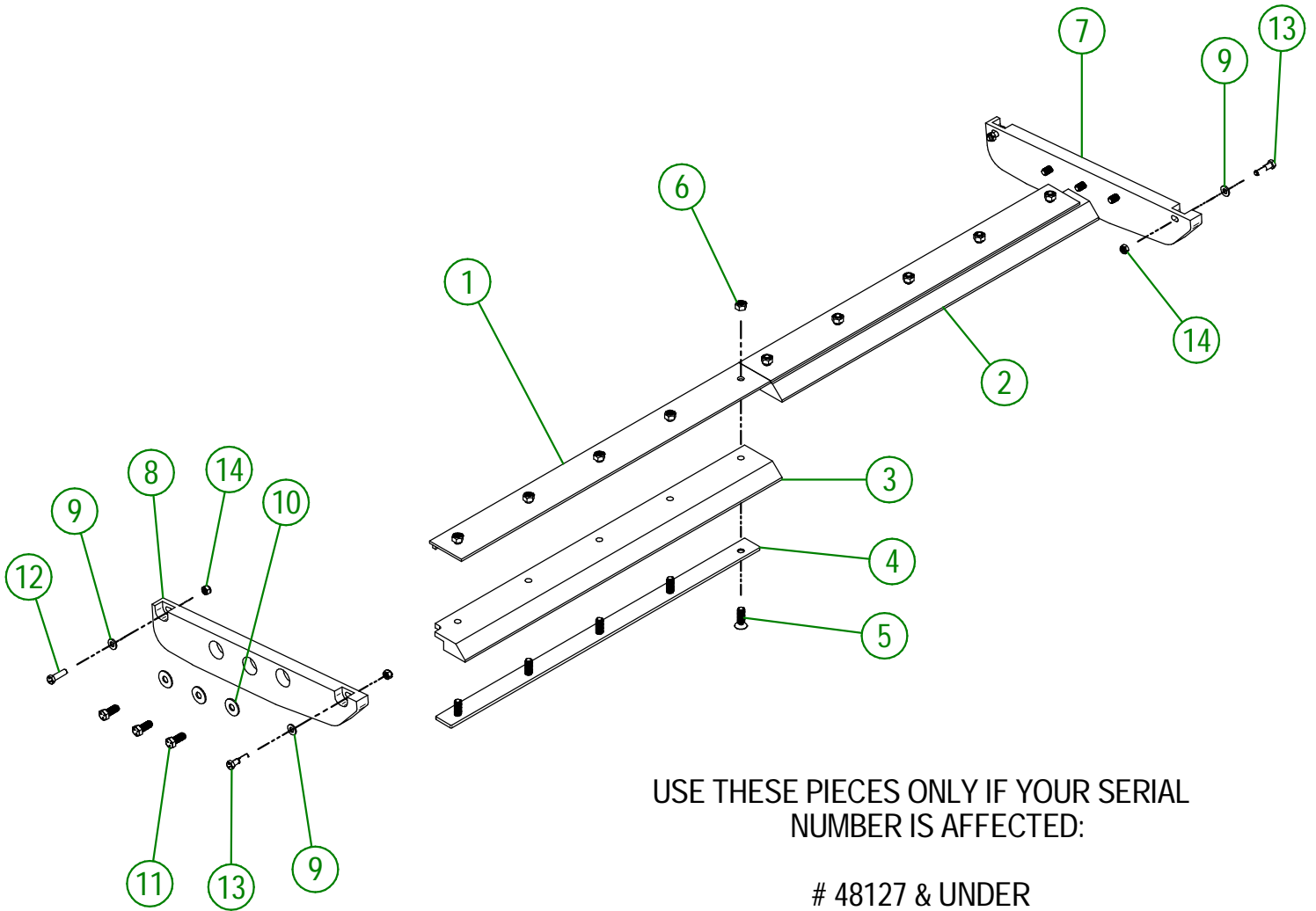

USE THESE PIECES ONLY IF YOUR SERIAL NUMBER IS AFFECTED:

# 48127 & UNDER

# 48128 & ABOVE USE THE PIECES ON THE NEXT PAGE

<b>AGRIMETAL</b>	
SET OF KNIVES (UHMW)	
CREATION : 21/08/23	ASSEMBLY : <b>102-57-0985</b>
REVISION : 11/11/25	AUTHOR : J. Houle

#	PART #	Qty	TITLE
1	81-50-0200	2	KNIFE BRACE (TOP)
2	81-42-0100	1	RIGHT KNIFE (UHMW)
3	81-42-0101	1	LEFT KNIFE (UHMW)
4	81-04-0355	2	KNIFE BRACE (UNDER)
5	NC01-93-0016	10	LOCK NUT ZINC 5/8-11
6	NC02-48-0564	10	FLAT HEAD SOCKET CAP SCREW STAINLESS 5/8-11 X 2" LG
7	81-42-0103	1	LATERAL KNIFE (RIGHT)
8	81-42-0104	1	LATERAL KNIFE (LEFT)
9	NC01-17-0394	6	HEX. BOLT GR2 ZINC 5/8-11 X 1 1/2"
10	80-04-0185	6	WASHER
11	NC02-25-0011	4	WASHER SAE ZINC 17/32 ID
12	NC01-17-0251	2	HEX. BOLT GR2 ZINC 1/2-13 X 2"
13	NC01-17-0250	2	HEX. BOLT GR2 ZINC 1/2-13 X 1 3/4"
14	NC01-93-0014	4	LOCK NUT ZINC 1/2-13

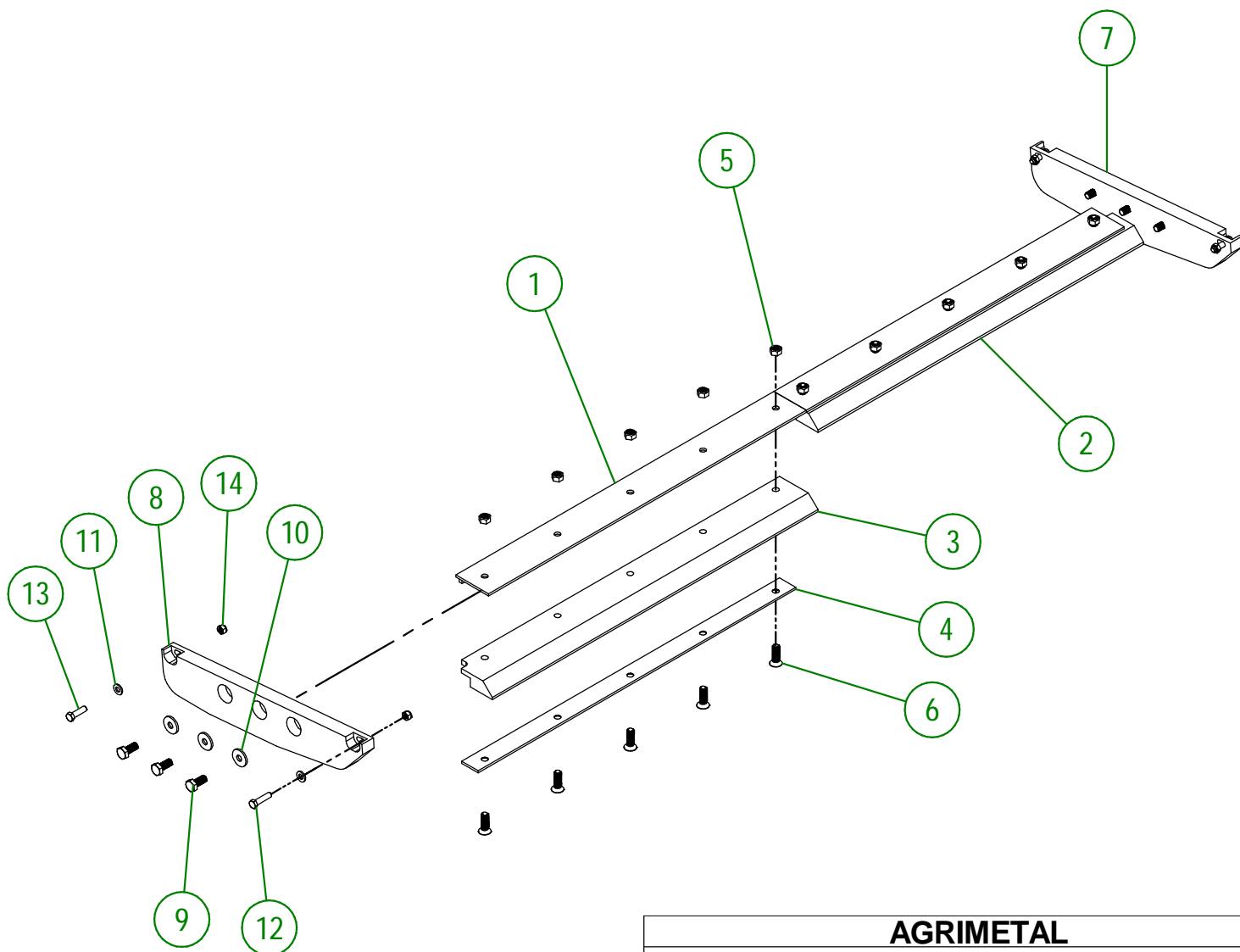

<b>AGRIMETAL</b>	
<b>SET OF KNIVES (UHMW)</b>	
CREATION : 18/07/16	ASSEMBLY : <b>81-57-0205</b>
REVISION : 27/09/23	AUTHOR : J. HOULE

102-57-0930

#	PART #	QTY	TITLE
1	102-57-0925	1	FRAME
2	102-50-0005	2	ATTACHMENT HAND
3	NC01-33-0481	4	HEX. BOLT GR8 ZINC 3/4-10 X 5 1/2"
4	22-04-6805	4	FLAT WASHER BEARING BASE
5	NC01-93-0017	4	HEX. LOCKNUT STEEL NC Z 3/4-10
6	NC02-07-0022	6	HEX. NUT ZINC 5/8-11
7	NC01-17-0396	6	HEX. BOLT GR2 ZINC 5/8-11 X 2"
8	48-20-0065	2	3 POINT PIN
9	48-20-0060	1	3 POINT PIN
10	NC01-69-1100	3	LINCH PIN 3/8"
11	NC13-15-0322	1	RUBBER
12	81-57-0250	1	RUBBER REINFORCEMENT
13	NC01-17-0060	7	HEX. BOLT GR2 ZINC 5/16-18 X 1"
14	NC01-93-0010	7	LOCK NUT ZINC 5/16-18
15	NC13-15-0300	1	SNOW GUARD
16	80-01-1075	1	SNOW GUARD BRACE
17	NC01-78-0041	6	POP RIVET STAINLESS STEEL ROD STEEL .187" X .690"
18	NC01-63-0026	1	COTTER PIN ZC 5/32" X 3"
19	81-50-0090	1	STAND
20	NC01-69-1306	1	LOCKING PIN 3/8" X 2 1/2" LG
21	NC01-69-0785	1	STRAIGHT GREASE FITTING 1/4-28

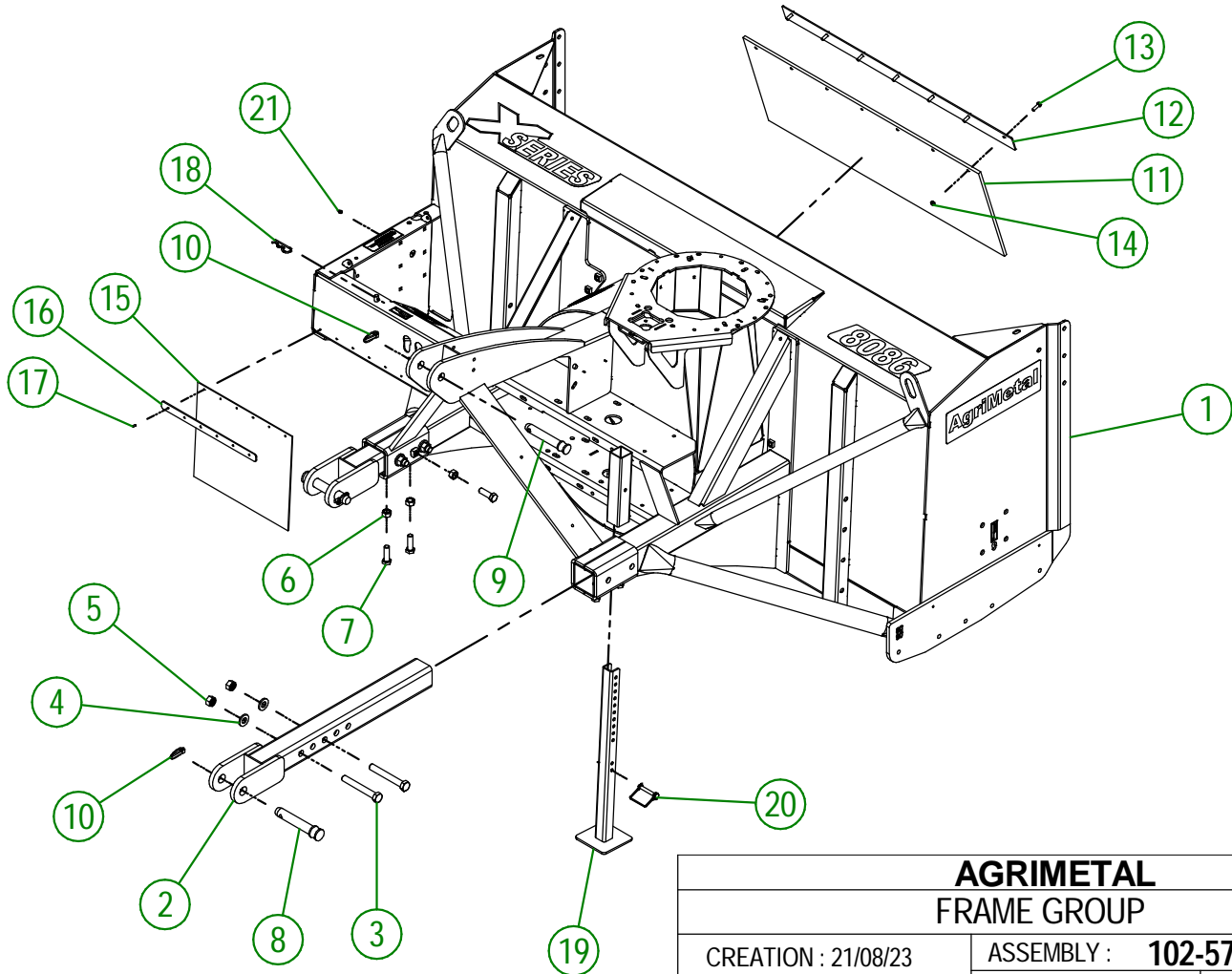

**AGRIMETAL**  
**FRAME GROUP**

CREATION : 21/08/23  
REVISION : 05/01/26

ASSEMBLY : **102-57-0930**  
AUTHOR : J. Houle

#	PART #	Qty	TITLE
1	80-55-0010	1	GEARBOX
2	NC02-25-0011	14	WASHER SAE ZINC 17/32 ID
3	NC02-32-0014	12	LOCK WASHER ZINC 1/2"
4	NC01-33-0253	4	HEX. BOLT GR8 ZINC 1/2-13 X 2 1/2"
5	NC01-33-0248	4	HEX. BOLT .GR8 NC ZINC 1/2-13 X 1 1/4"
6	81-21-0005	4	TRANSMISSION BUSHING
7	80-41-0135	1	PTO GUARD STEEL CABLE
8	NC01-64-0005	2	OVAL SLEEVE (ALUMINUM)
9	80-41-0900	1	IMPELLER KEY
10	NC13-25-0019	1	BLACK TIE RAP
11	NC13-50-0110	1	IMPORTANT/NOTICE PTO POSTER
12	81-57-0040	1	PTO GUARD
13	81-34-0035	1	PTO SHAFT T80
14	NC01-63-0027	1	HAIRPIN COTTER
15	80-04-0485	1	GEARBOX BRACE
16	80-04-0480	1	GEARBOX BRACE
17	81-01-0921	1	PTO GUARD SUPPORT
18	NC01-33-0249	4	CAP SCREW GR8 NC ZINC 1/2-13 X 1 1/2" LG
19	NC02-07-0020	4	HEX. NUT ZINC 1/2-13

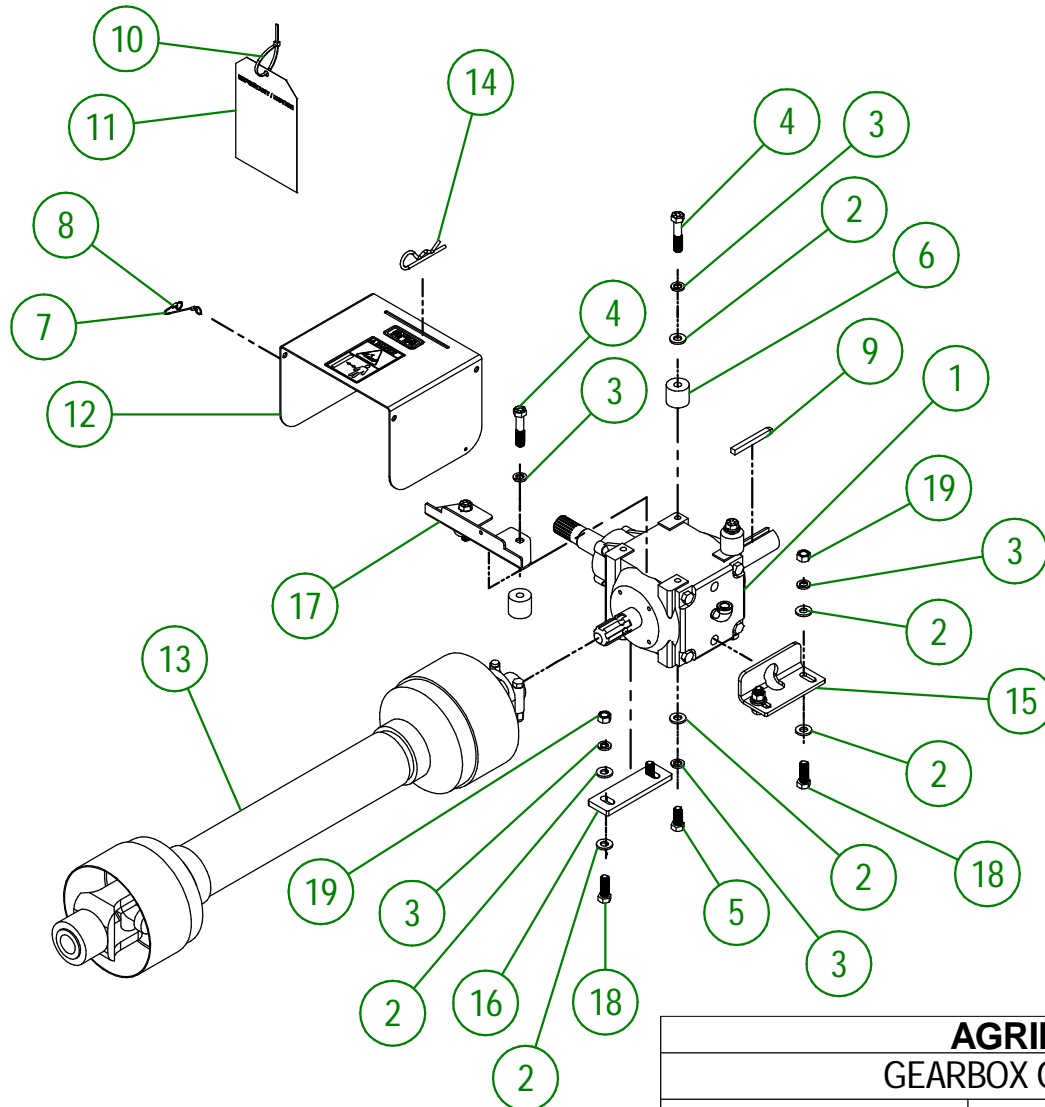

**AGRIMETAL**  
**GEARBOX GROUPING**

CREATION : 19/07/16  
 REVISION : 21/08/23

ASSEMBLY : **81-57-0430**  
 AUTHOR : Dessin2

102-57-1020

#	PART #	Qty	TITLE
1	102-50-1025	1	IMPELLER
2	80-04-0185	1	WASHER
3	NC02-32-0016	1	LOCK WASHER ZINC 5/8"
4	NC01-25-0395	1	HEX. BOLT GR5 ZINC 5/8-11 X 1 3/4" LG
5	NC01-37-0255	2	HEX BOLT GR8 1/2" X 3" LG.
6	NC01-94-0013	2	NYLON NUT ZINC 1/2-20"

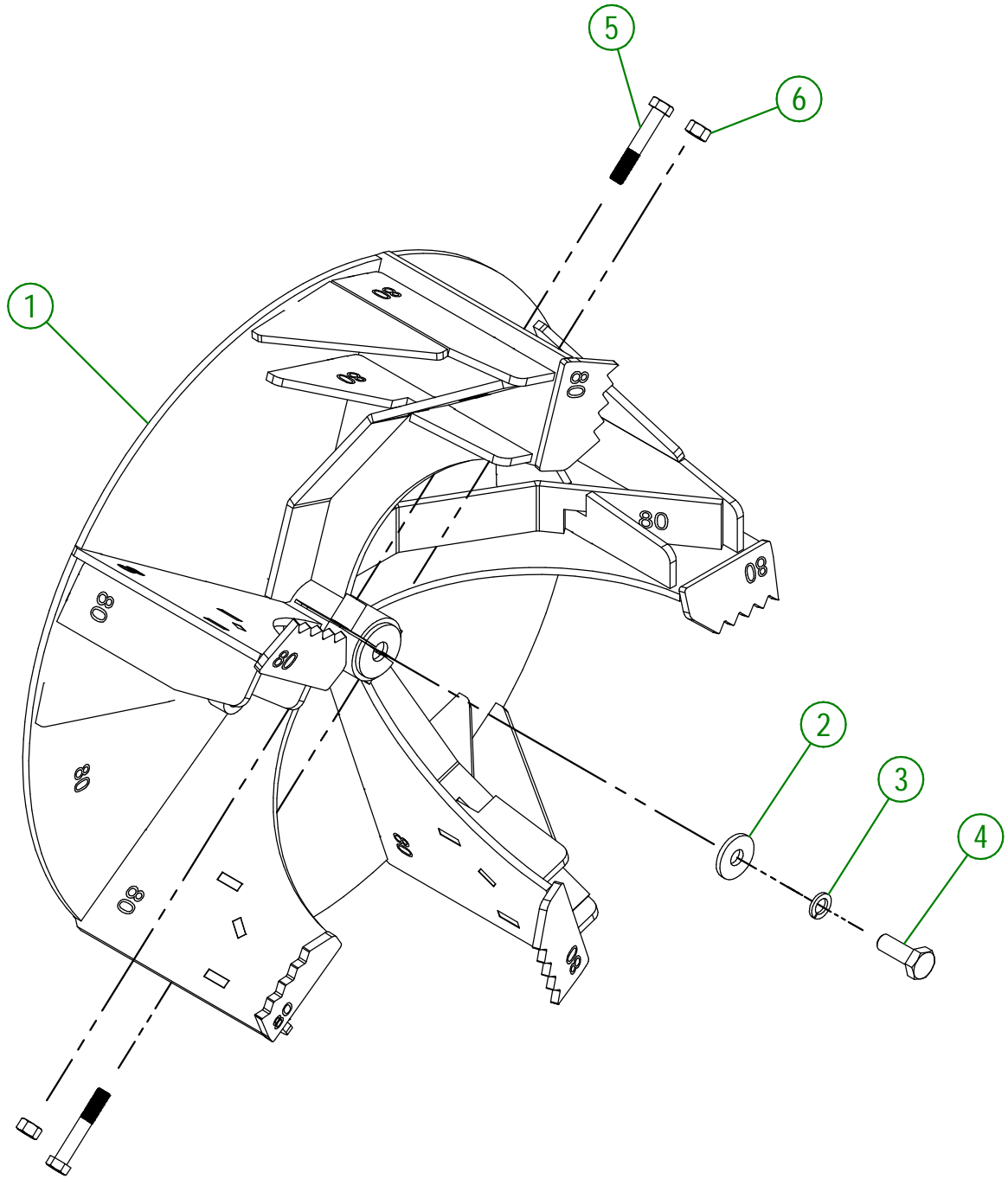

<b>AGRIMETAL</b>	
<b>IMPELLER GROUP</b>	
CREATION : 21/08/23	ASSEMBLY : <b>102-57-1020</b>
REVISION : 21/08/23	AUTHOR : J. Houle

102-57-1035

#	PART #	Qty	TITLE
1	102-50-1040	1	LEFT SNOW GUARD
2	102-50-1045	1	RIGHT SNOW GUARD
3	NC02-32-0014	6	LOCK WASHER ZINC 1/2"
4	NC01-25-0249	6	HEX. BOLT GR5 ZINC 1/2-13 X 1 1/2" LG

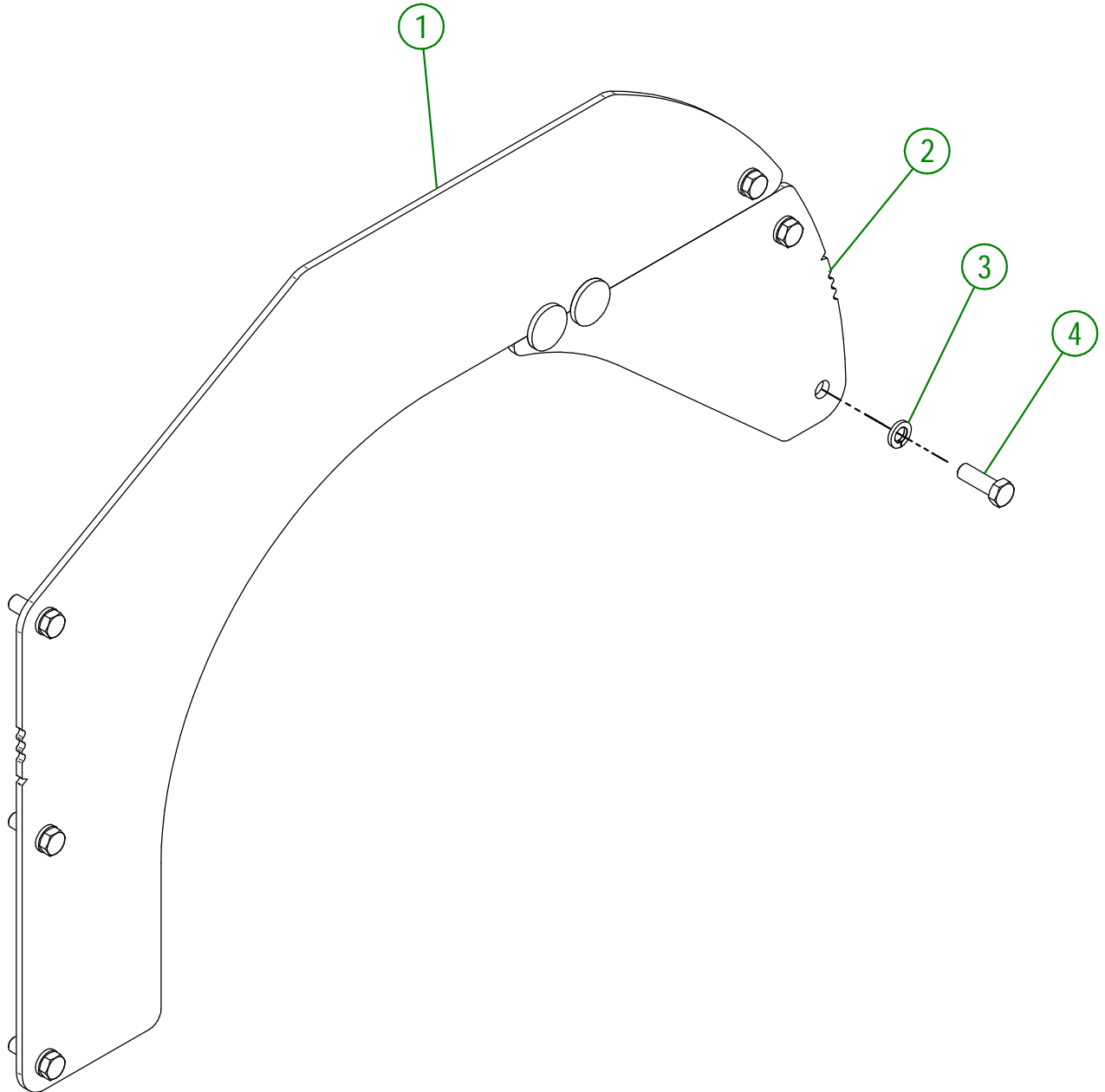

<b>AGRIMETAL</b>	
<b>SNOW GUARD GROUP</b>	
CREATION : 21/08/23	ASSEMBLY : <b>102-57-1035</b>
REVISION : 21/08/23	AUTHOR : J. Houle

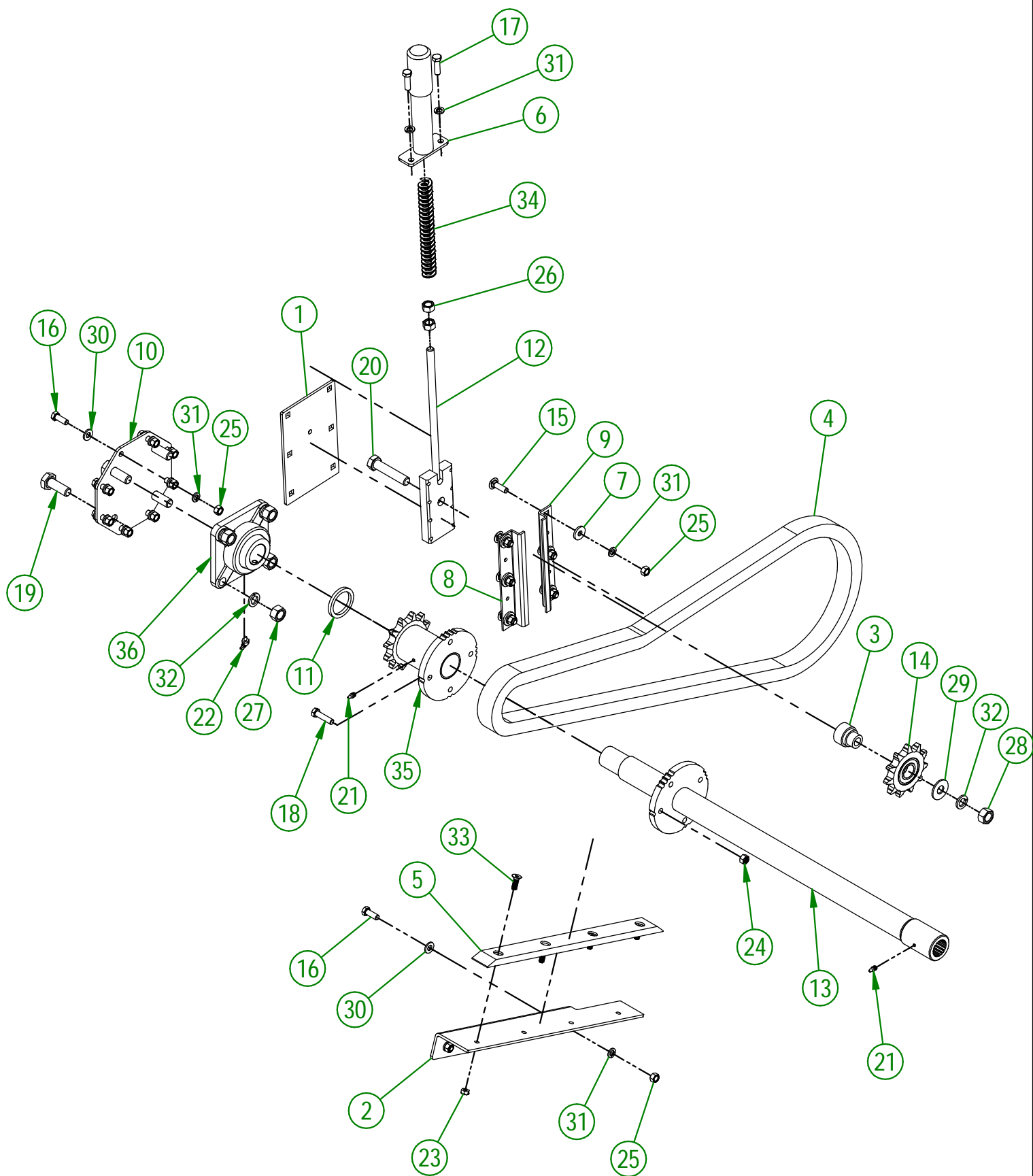

<b>AGRIMETAL</b>	
<b>SPIRAL DRIVE TRAIN GROUP</b>	
CREATION : 21/08/23	ASSEMBLY : <b>102-57-0970</b>
REVISION : 15/01/26	AUTHOR : J. Houle

102-57-0970

#	PART #	Qty	TITLE
1	102-04-0180	1	CHAIN TENSIONER HOLD DOWN PLATE
2	102-04-0365	1	WEAR STRIP HOLDER
3	102-21-0015	1	CHAIN TENSIONER BUSHING
4	102-37-0005	1	#80 CHAIN
5	102-42-0010	1	SLIDING CHAIN STRIP
6	102-50-1065	1	SPRING GUIDE
7	21-01-0950	6	FLAT WASHER 10GA 1.005" DIA X 25/64"
8	81-01-0927	1	SUPPORT FOR CHAIN TENSIONER
9	81-01-0928	1	SUPPORT FOR CHAIN TENSIONER
10	81-04-0010	1	BEARING SUPPORT
11	81-21-0010	1	SPIRAL DRIVE TRAIN BUSHING
12	81-50-0078	1	SUPPORT FOR CHAIN TENSIONER
13	81-50-6010	1	SPIRAL DRIVE TRAIN
14	81-55-0005	1	CHAIN TENSIONER SPROCKET
15	NC01-07-0110	6	CARR. BOLT GR5 ZINC 3/8-16 X 1 1/4"
16	NC01-25-0114	11	HEX. BOLT GR5 ZINC 3/8-16 X 1"
17	NC01-25-0115	2	HEX. BOLT GR5 ZINC 3/8-16 X 1 1/4"
18	NC01-25-0116	1	HEX. BOLT GR5 ZINC 3/8-16 X 1 1/2"
19	NC01-25-0395	4	HEX. BOLT GR5 ZINC 5/8-11 X 1 3/4" LG
20	NC01-29-0400	1	HEX. BOLT GR5 ZINC 5/8-18 X 3"
21	NC01-69-0785	2	STRAIGHT GREASE FITTING 1/4-28
22	NC01-69-0802	1	GREASE FITTING 6mm X 45mm
23	NC01-93-0010	4	LOCK NUT ZINC 5/16-18
24	NC01-93-0011	1	LOCK NUT 3/8-16
25	NC02-07-0018	17	HEX. NUT ZINC 3/8-16
26	NC02-07-0020	2	HEX. NUT ZINC 1/2-13
27	NC02-07-0022	4	HEX. NUT ZINC 5/8-11
28	NC02-10-0022	1	HEX. NUT ZINC 5/8-18
29	NC02-22-0013	1	WASHER ZINC 5/8 ID X 1 1/2 OD
30	NC02-26-1525	11	WASHER 0.406" I.D. X 0.815 O.D.
31	NC02-32-0012	19	LOCK WASHER ZINC 3/8"
32	NC02-32-0016	5	LOCK WASHER ZINC 5/8"
33	NC02-48-0021	4	FLAT HEAD SOCKET CAP SCREW 5/16-18 X 1"
34	NC13-86-0369	1	GREEN SPRING 1/2" ID X 1" OD X 8" LG
35	NC14-55-0328	1	SPROCKET
36	NC14-75-0025	1	FLANGE BEARING 4 HOLES UCF 208-24 X 1 1/2"

102-57-1055

#	PART #	Qty	TITLE
1	102-57-1060	1	CHAIN GUARD
2	NC02-26-1525	4	WASHER INOX .406" D.I. X .815" D.E.
3	NC01-17-0114	2	HEX. BOLT GR2 ZINC 3/8-16 X 1"
4	NC01-96-0011	2	NYLON NUT 3/8-16

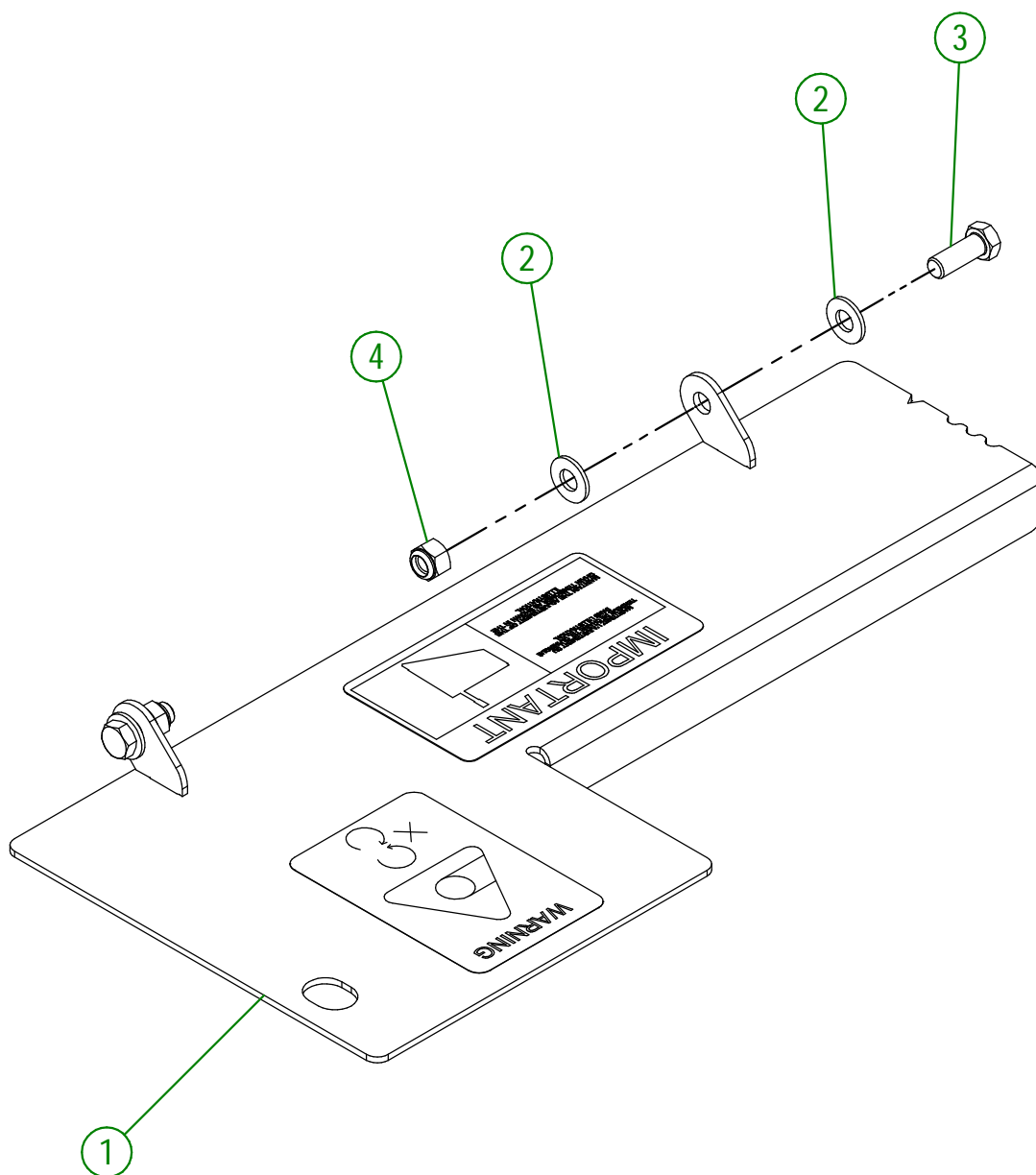

<b>AGRIMETAL</b>	
<b>CHAIN GUARD GROUP</b>	
CREATION : 21/08/23	ASSEMBLY : <b>102-57-1055</b>
REVISION : 19/12/25	AUTHOR : J. Houle

102-57-0940

#	PART #	QTY	TITLE
1	NC14-75-0161	2	FLANGE BEARING UCF 208-24 1 1/2" ID
2	102-50-0930	1	SPIRAL
3	NC02-32-0016	8	LOCK WASHER ZINC 5/8"
4	NC02-07-0022	8	HEX. NUT ZINC 5/8-11
5	NC02-25-0013	8	WASHER ZINC SAE ZINC 21/32 ID
6	NC01-17-0396	8	HEX. BOLT GR2 ZINC 5/8-11 X 2"
7	NC14-55-0275	1	SPROCKET 80A34 X 1 1/2"
8	NC01-37-0249	4	HEX. BOLT GR8 NC ZINC 1/2-20 X 1 1/2"
9	NC01-94-0013	4	HEX. LOCK NUT NF ZINC 1/2-20
10	102-51-1070	1	SHAFT OF THE SPIRAL
11	102-51-1075	1	SHAFT OF THE SPIRAL (SPROCKET)

REBUILT KIT

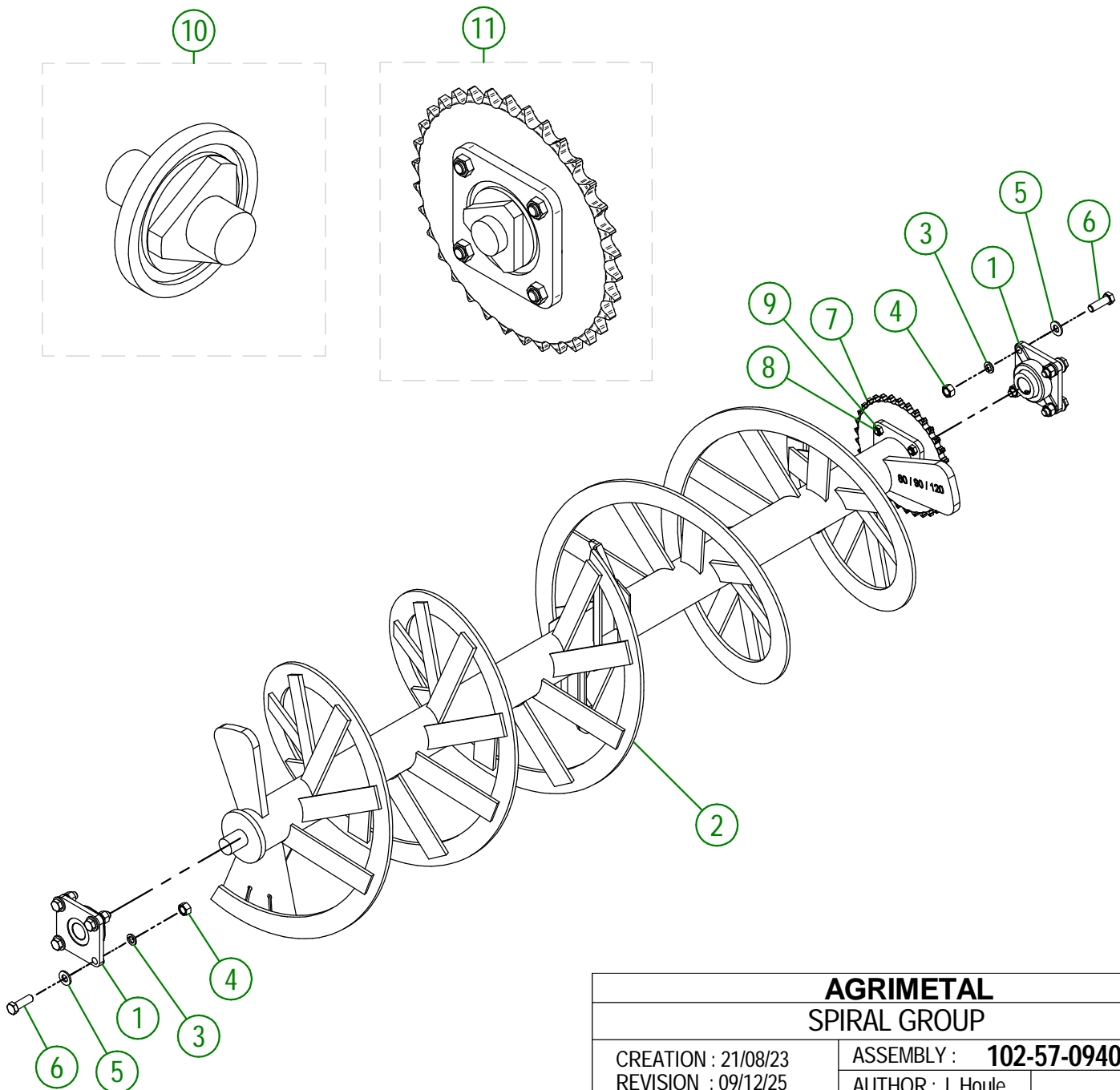

**AGRIMETAL**  
**SPIRAL GROUP**

CREATION : 21/08/23  
REVISION : 09/12/25

ASSEMBLY : **102-57-0940**  
AUTHOR : J. Houle

102-57-1065

#	PART #	Qty	TITLE
1	102-50-1050	1	CHAIN GUARD
2	NC01-04-0109	5	CARR. BOLT GR2 ZINC 3/8-16 X 1"
3	NC02-14-0019	5	FLANGE NUT HEX. NC 3/8-16 GR. B

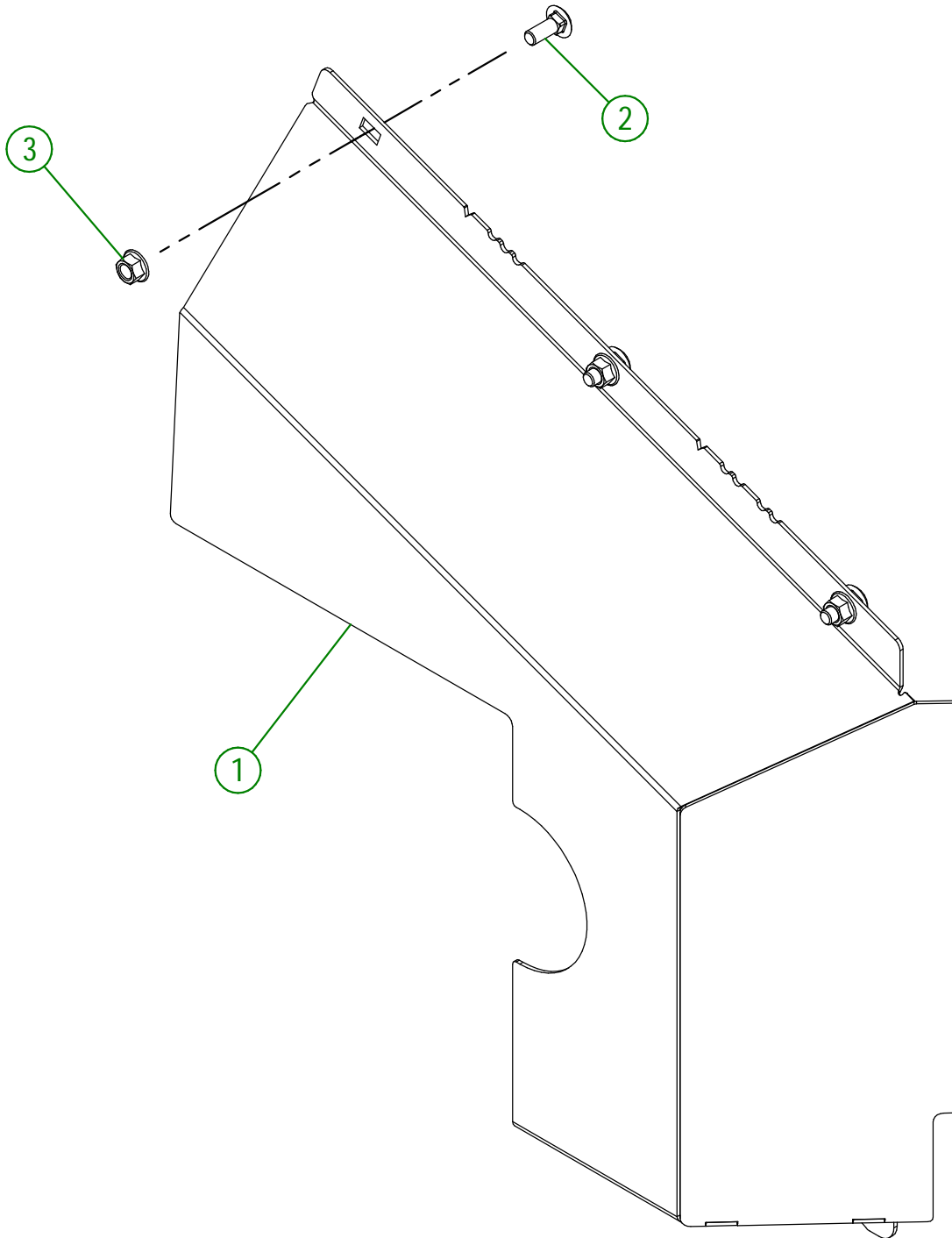

<b>AGRIMETAL</b>	
<b>SPIRAL CHAIN GUARD GROUP</b>	
CREATION : 21/08/23	ASSEMBLY : <b>102-57-1065</b>
REVISION : 21/08/23	AUTHOR : J. Houle

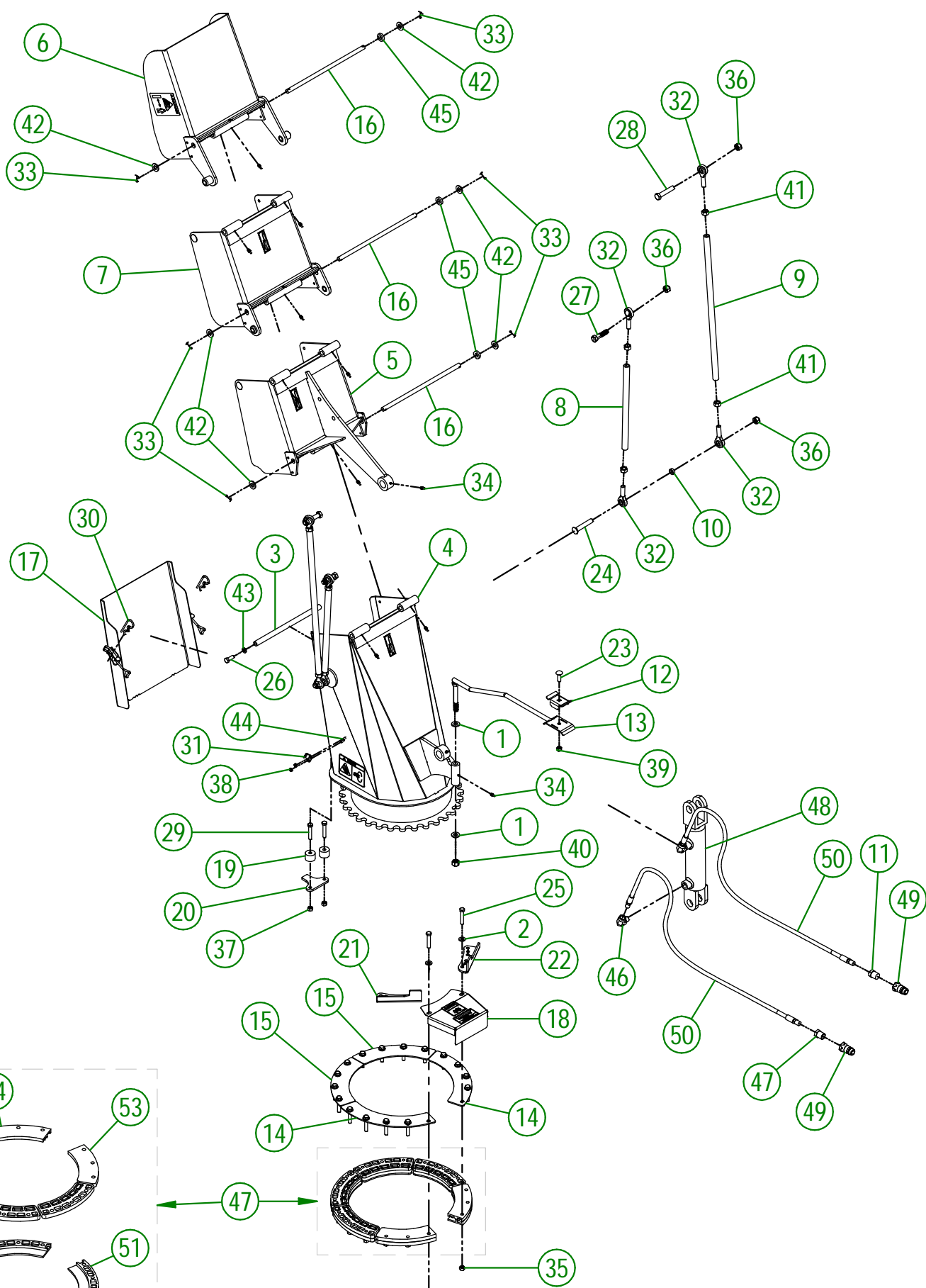

**AGRIMETAL**  
**CHUTE (12") GROUP**

CREATION : 21/08/23  
 REVISION : 19/12/25

ASSEMBLY : **102-57-1046**  
 AUTHOR : J. Houle

## 102-57-1046

#	PART #	Qty	TITLE
1	01-01-0925	2	WASHER
2	NC02-26-1525	18	WASHER 0.406" I.D. X 0.815 O.D.
3	102-13-0040	1	CHUTE REINFORCEMENT
4	102-57-1001	1	BOTTOM SECTION
5	102-57-1011	1	FIRST SECTION
6	102-57-1016	1	THIRD SECTION
7	102-57-1075	1	SECOND SECTION
8	103-13-0000	2	CHUTE ROD (TRIPLE)
9	103-13-0005	2	CHUTE ROD (TRIPLE)
10	103-13-0025	2	CHUTE ROD SPACER
11	103-25-0000	1	1/2 NPT STRAIGHT UNION X 3/64"
12	48-01-7530	1	HYDRAULIC HOSE SUPPORT
13	48-50-1030	1	HYDRAULIC HOSE SUPPORT
14	80-01-1010	2	BRACE
15	80-01-1015	2	BRACE
16	80-20-0260	3	PIVOT
17	80-57-0353	1	CHUTE DOOR
18	80-57-0550	1	SPROCKET GUARD GROUP "STICKER INCLUDED"
19	81-21-0040	2	ADJUSTABLE STOPPER SPACER
20	84-04-0170	1	STOPPER
21	84-04-0175	1	ADJUSTABLE STOPPER
22	84-04-0177	1	ADJUSTABLE STOPPER
23	NC01-04-0110	1	CARR. BOLT GR2 ZINC 3/8-16 X 1 1/4"
24	NC01-07-0241	2	CARR. BOLT GR5 ZINC 1/2-13 X 3" LG
25	NC01-17-0118	18	HEX. BOLT GR2 ZINC 3/8-16 X 2"
26	NC01-25-0114	2	HEX. BOLT GR5 ZINC 3/8-16 X 1"
27	NC01-25-0251	2	HEX.BOLT GR5 NC ZINC 1/2-13 X 2"
28	NC01-25-0253	2	HEX. BOLT GR5 NC ZINC 1/2-13 X 2 1/2"
29	NC01-37-0118	2	HEX. BOLT GR8 ZINC 3/8-24 X 2"
30	NC01-63-0026	2	COTTER PIN ZC 5/32" X 3"
31	NC01-63-0052	2	ADJUSTABLE LATCH (STRIKE)
32	NC01-67-0306	8	1/2-20 ROD END
33	NC01-69-0139	6	COTTER PIN ZINC 1/8" X 3/4"
34	NC01-69-0785	12	STRAIGHT GREASE FITTING 1/4-28
35	NC01-93-0011	18	LOCK NUT 3/8-16
36	NC01-93-0014	6	LOCK NUT ZINC 1/2-13
37	NC01-94-0011	2	LOCK NUT 3/8-24
38	NC01-96-0006	4	NYLON NUT ZINC 3/16
39	NC01-96-0011	1	NYLON NUT 3/8-16
40	NC01-96-0014	1	NYLON-INSERT LOCKNUT ZINC 1/2-13
41	NC02-10-0020	8	HEX. NUT ZINC 1/2-20
42	NC02-25-0011	6	WASHER SAE ZINC 17/32 ID
43	NC02-32-0012	2	LOCK WASHER ZINC 3/8"
44	NC02-40-0080	4	MACHINE SCREWS SQUARE SOCKET #10-24 X 1/2" LG
45	NC13-15-0334	6	PIVOT WASHER
46	NC13-45-0038	2	ELBOW 90 3/8 FEM. NPT X 3/8 MALE NPT

## 102-57-1046

#	PART #	Qty	TITLE
47	NC13-45-0153	1	HEX. REDUCER 1/4 NPT X 1/2 NPT
48	NC13-45-0217	1	HYDRAULIC CYLINDER 4" STROKE
49	NC13-45-0369	2	QUICK COUPLER 1/2-14 NPTF
50	NC17-02-0347	2	HYDRAULIC HOSE (111" LG)

## 84-57-1330

#	PART #	Qty	TITLE
51	80-42-0305	1	CHUTE GUIDE (UNDER)
52	80-42-0310	1	CHUTE GUIDE (UNDER)
53	80-42-0315	1	CHUTE GUIDE (TOP)
54	80-42-0320	1	CHUTE GUIDE (TOP)
55	NC17-46-0027	4	CHUTE GUIDE (UNDER)
56	NC17-46-0028	4	CHUTE GUIDE (TOP)

#	PART #	Qty	TITLE
1	48-01-7527	1	HYDRAULIC HOSE SUPPORT
2	48-50-1025	1	HYDRAULIC ENGINE SPROCKET
3	80-13-0100	2	HYDRAULIC RESTRICTOR
4	80-45-0000	2	HEX. REDUCER 1/4 NPT X 1/2 NPT
5	81-01-7600	1	HYDRAULIC HOSE SUPPORT
6	NC01-04-0111	1	CARR. BOLT GR2 ZINC 3/8-16 X 1 1/2"
7	NC01-17-0115	2	HEX. BOLT GR2 ZINC 3/8-16 X 1 1/4"
8	NC01-33-0113	4	HEX.BOLT GR8 ZINC 3/8-16 X 3/4"
9	NC01-45-0184	1	HEX. BOLT GR8.8 ZINC 8MM X 20MM
10	NC01-96-0011	1	NYLON NUT 3/8-16
11	NC02-07-0018	2	HEX. NUT ZINC 3/8-16
12	NC02-26-0504	1	WASHER
13	NC02-26-1525	2	WASHER INOX .406" D.I. X .815" D.E.
14	NC02-32-0011	1	LOCK WASHER ZINC 5/16"
15	NC02-32-0012	6	LOCK WASHER ZINC 3/8"
16	NC02-44-0103	2	SET SCREW 5/16-18 X 3/8"
17	NC13-45-0367	2	45°-7/8-14 MALE O RING X 1/2 FEM.TOUR.NPT PT
18	NC13-45-0369	2	QUICK COUPLER 1/2-14 NPTF
19	NC13-45-0378	2	HYDRAULIC RESTRICTOR BUSHING
20	NC14-45-0156	1	HYDRAULIC MOTOR
21	NC17-02-0406	2	HYDRAULIC HOSE (87" LG)
22	NC17-46-0031	1	HYDRAULIC MOTOR BUSHING

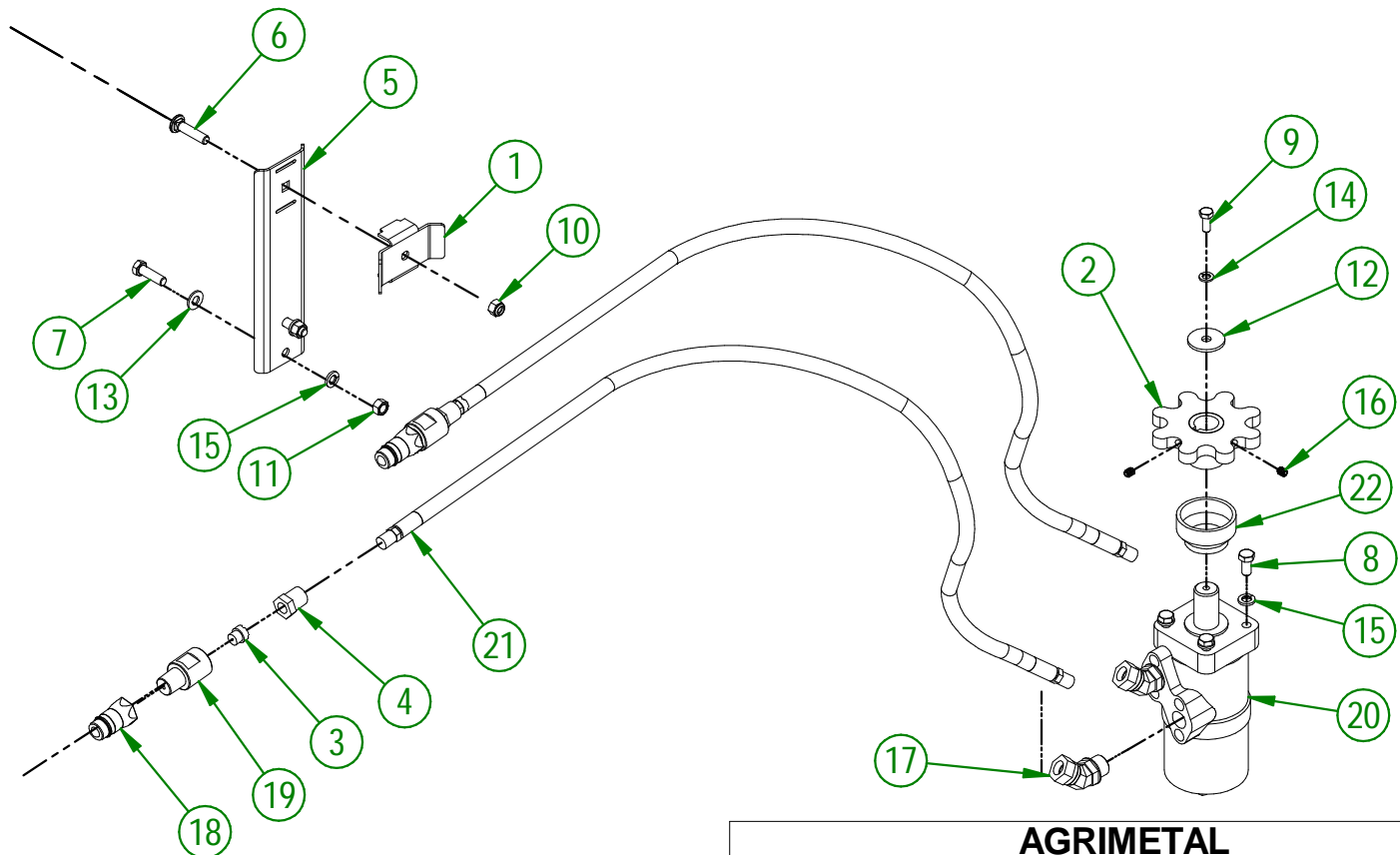

**AGRIMETAL**  
HYDRAULIC MOTOR GROUP

CREATION : 05/12/17  
REVISION : 25/03/26

ASSEMBLY : **81-57-5045**  
AUTHOR : F.HÉLIE

81-57-0215

#	PART #	Qty	TITLE
1	81-20-0337	1	LATERAL CUTTER BLADES (LEFT)
2	81-20-0335	1	LATERAL CUTTER BLADES (RIGHT)
3	81-10-0000	4	LATERAL CUTTER BLADES BUSHING
4	NC01-33-0248	10	HEX. BOLT .GR8 NC ZINC 1/2-13 X 1 1/4"
5	NC01-33-0514	4	HEX. BOLT GR8 ZINC 1/2-13 X 2 1/4"
6	NC02-32-0014	14	LOCK WASHER ZINC 1/2"
7	NC02-07-0020	14	HEX. NUT ZINC 1/2-13
8	81-04-0525	2	LATERAL KNIFE REINFORCE
9	NC02-22-0012	2	WASHER ZINC 1/2 BOLT = 9/16"Ø X 1 3/8" OD

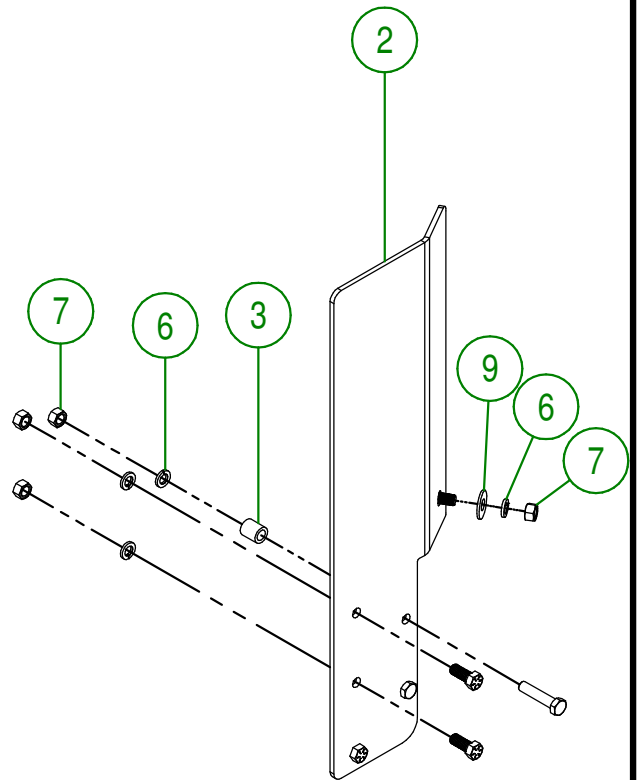
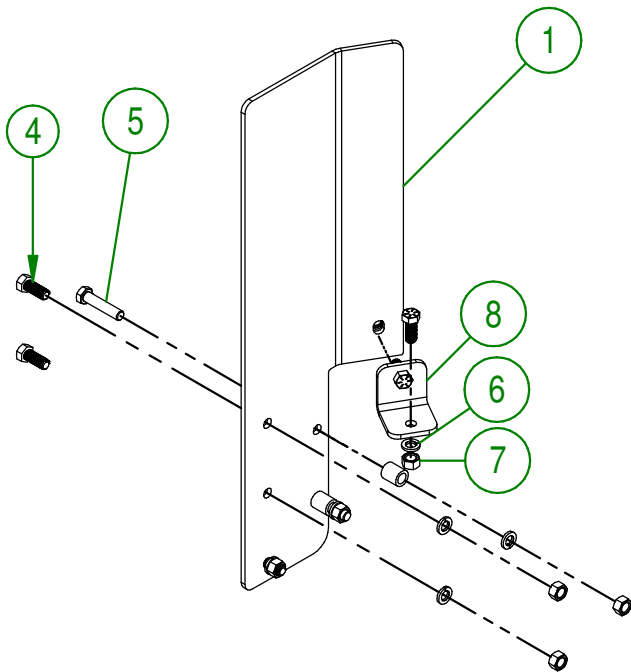

<b>AGRIMETAL</b>	
<b>LATERAL CUTTER BLADES</b>	
CREATION : 24/11/17	ASSEMBLY : <b>81-57-0215</b>
REVISION : 06/12/21	AUTHOR : J. Houle

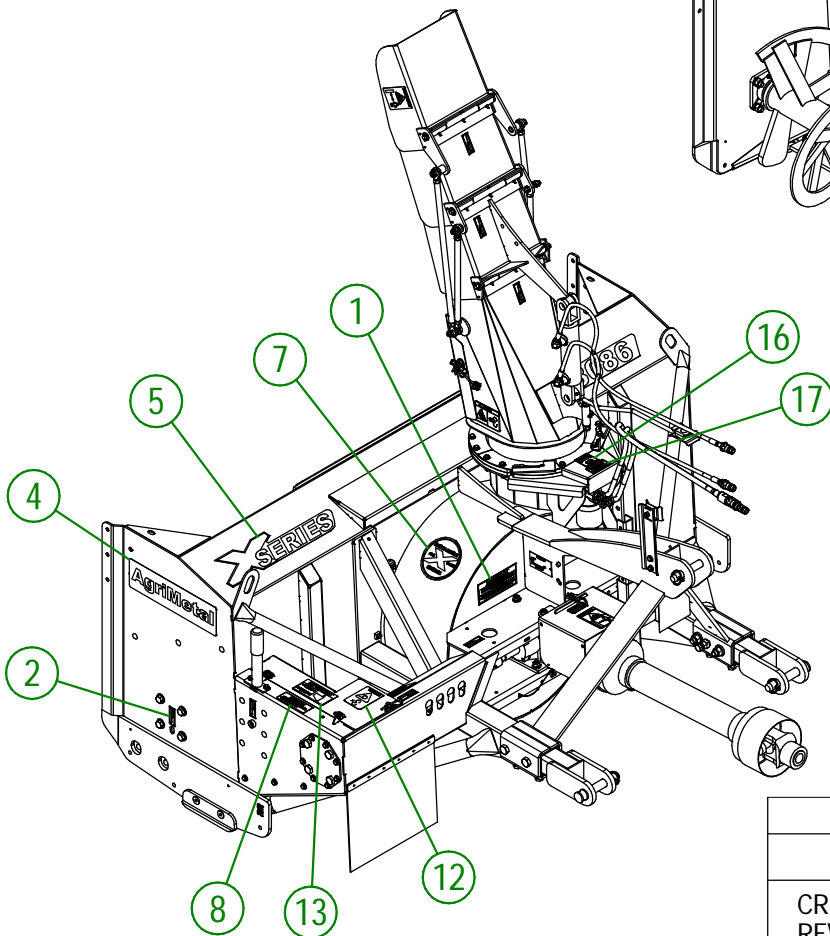
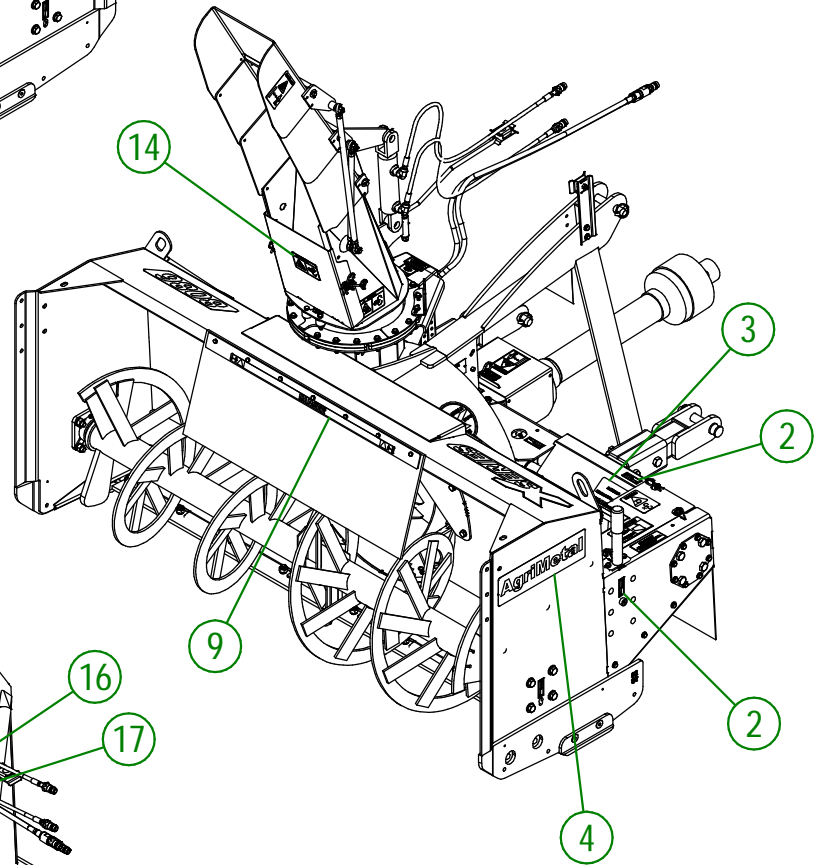
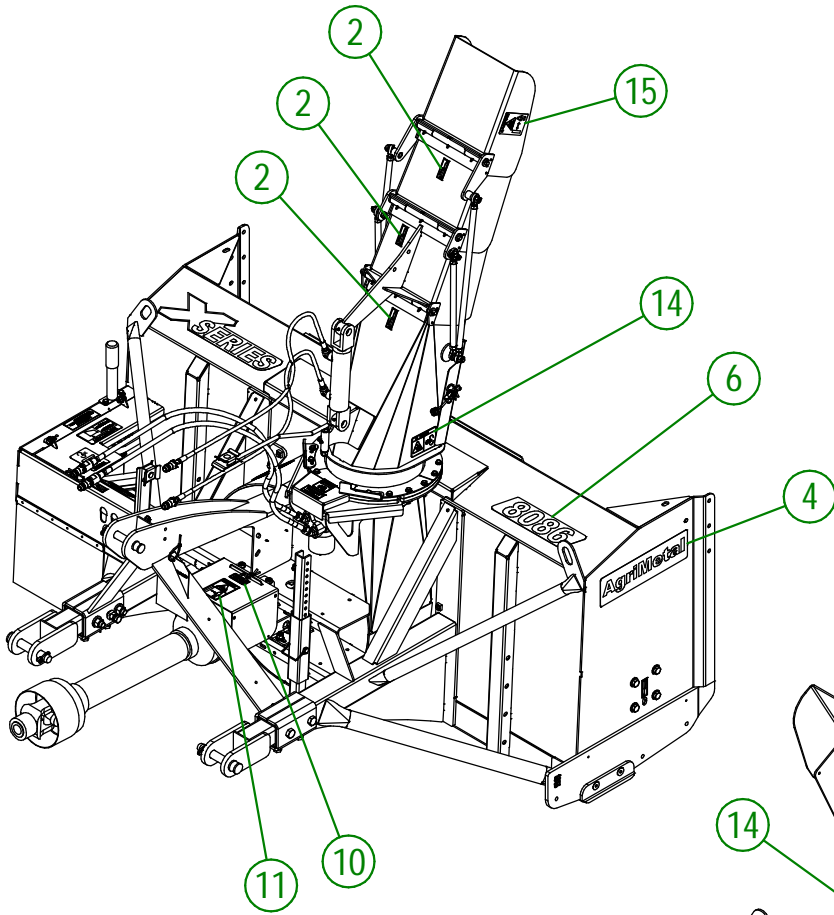

## AGRIMETAL

8086

CREATION : 22/08/23  
REVISION : 27/06/25

ASSEMBLY : **102-99-0900**  
AUTHOR : J. Houle

102-99-0900

#	PART #	QTY	TITLE
1	NC13-33-0317	1	STICKER GREASE DRIVE LINE TELESCOPIC SHAFT
2	NC13-33-0024	8	STICKER GREASE HERE
3	NC13-33-0281	1	STICKER SHEAR BOLT
4	NC13-33-0001	2	STICKER AGRIMETAL
5	NC13-33-2670	1	STICKER X SERIES
6	NC13-33-2666	1	STICKER 8086
7	NC13-33-2669	1	STICKER ANGLE RIGHT
8	NC13-33-0343	1	GREASE CHAIN EVERY 10 HOURS STICKER
9	NC13-33-0274	1	STICKER DANGER
10	NC13-33-0005	3	STICKER MAXIMUM 540 RPM
11	NC13-33-0187	3	STICKER DANGER (PTO AND PERSON)
12	NC13-33-0283	1	STICKER DANGER (PERSON AND CHAIN DRIVE)
13	NC13-33-2676	1	IMPORTANT MAINTAIN THE ADJUSTMENT OF THE CHAIN TENSIONER
14	NC13-33-0249	3	STICKER DANGER
15	NC13-33-0192	2	STICKER (PROJECTION RISK)
16	NC13-33-0326	1	STICKER DANGER (HAND)
17	NC13-33-0327	1	STICKER END ROTATION ADJUSTMENT