

# AgriMetal

## PART LIST

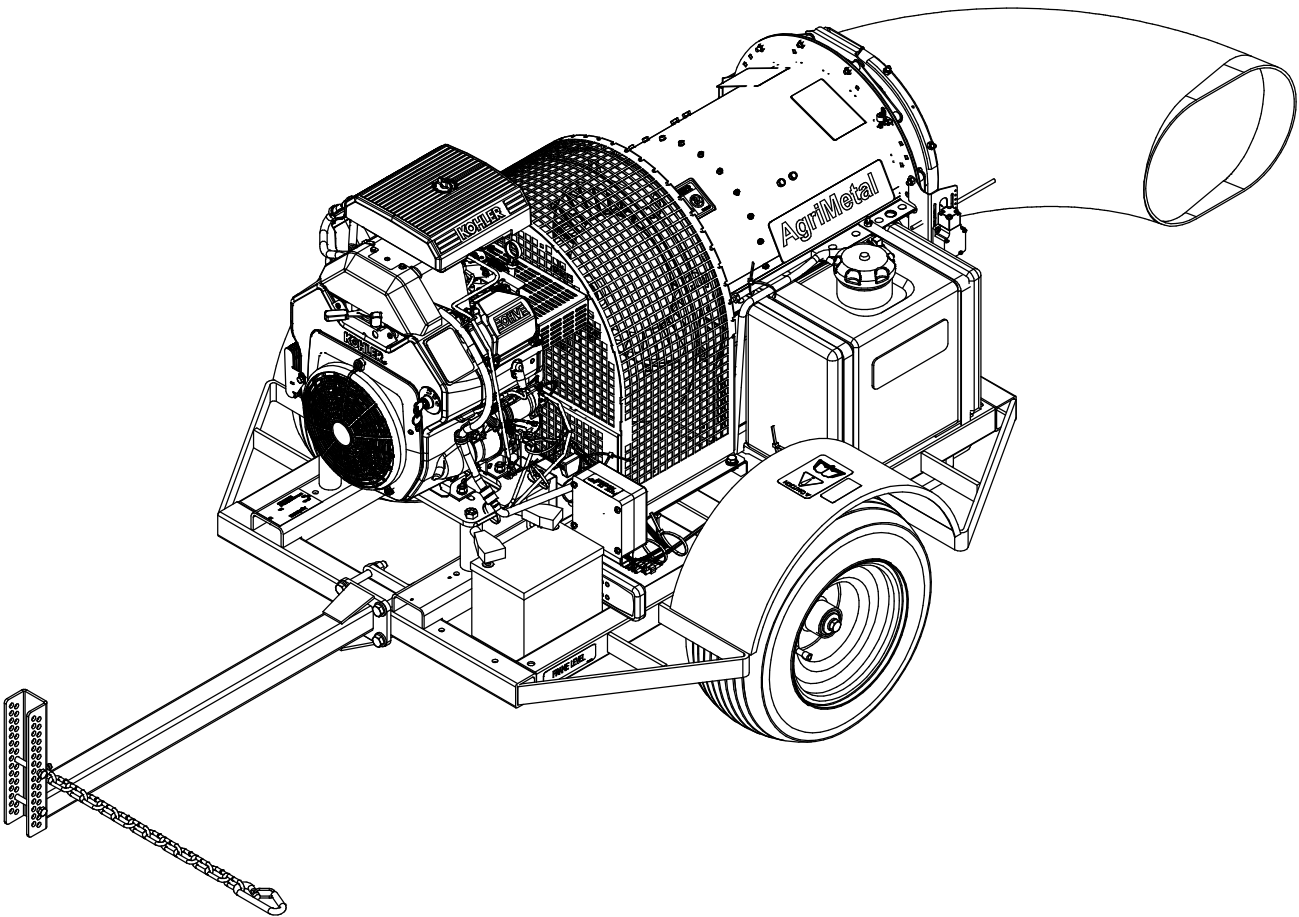

## TURBINE BLOWER 270 IC

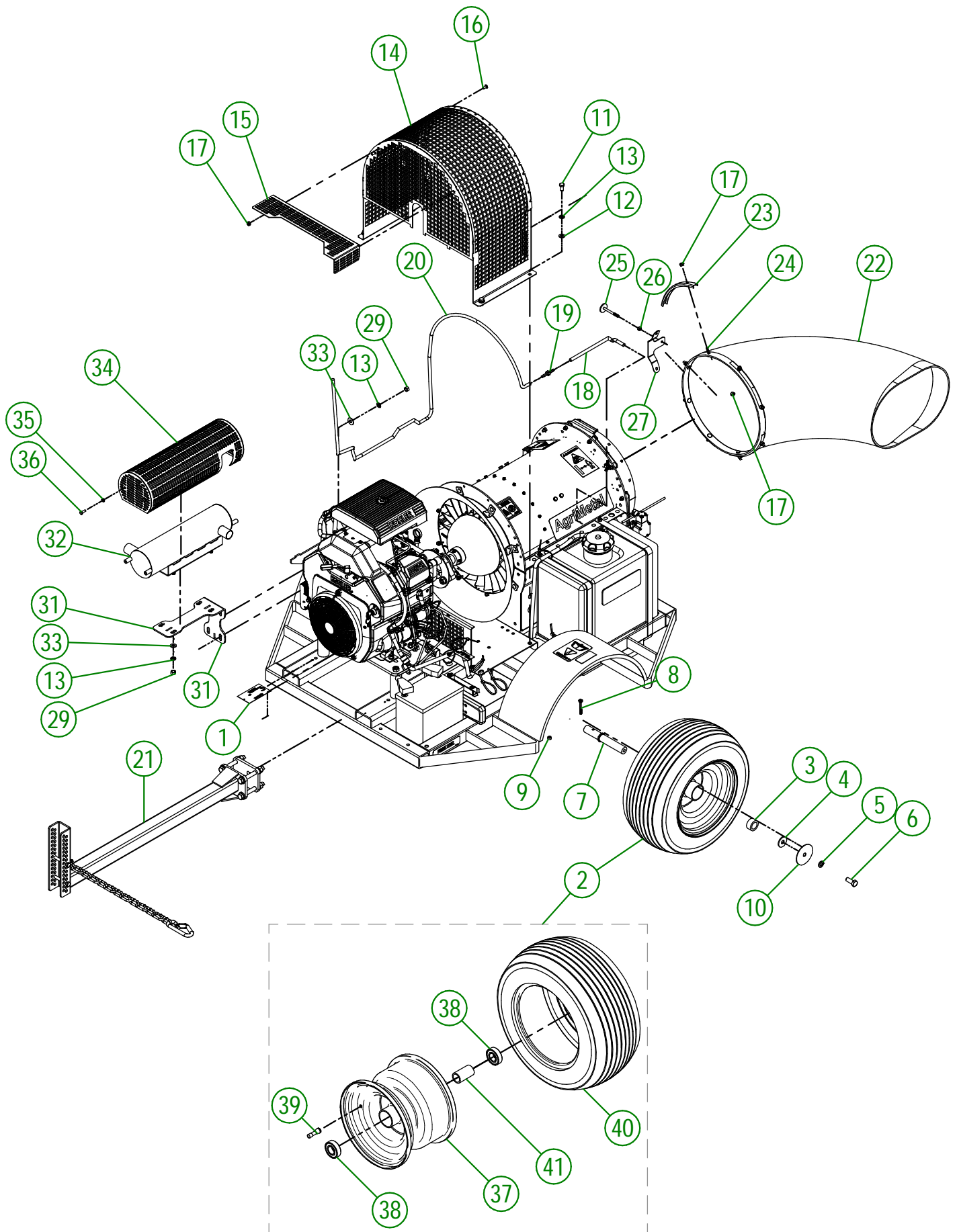

**AGRIMETAL**

**TURBINE BLOWER 270 IC**

CREATION : 08/05/25  
 REVISION : 12/05/25

ASSEMBLY : **33-99-2600**  
 AUTHOR : J.Houle

## 33-99-2600

#	PART #	QTY	TITLE
1	25-55-0710	1	SERIAL NUMBER PLATE
2	33-55-0125	2	ASSEMBLY WHEEL 18X9.50-8 WITH BALL BEARING
3	33-21-0065	2	WHEEL BUSHING
4	NC02-22-0012	2	WASHER ZINC 1/2 BOLT = 9/16"Ø X 1 3/8" OD
5	NC02-32-0014	2	LOCK WASHER ZINC 1/2"
6	NC01-17-0248	2	HEX. BOLT GR2 ZINC 1/2-13 X 1 1/4"
7	33-13-0100	2	AXLE SHAFT
8	NC01-33-0010	2	GRADE 8 HEX HEAD SCREW 1/4-20 X 2" LG.
9	NC01-93-0001	2	HEX. LOCK NUT NC ZINC 1/4-20
10	33-01-0400	2	BEARING SHEILD
11	NC01-17-0112	4	HEX. BOLT GR2 ZINC 3/8-16 X 3/4"
12	01-01-2485	4	FLAT WASHER 14 GA X 13/16"OD X 25/64" ID
13	NC02-32-0012	12	LOCK WASHER ZINC 3/8"
14	33-50-0035	1	TURBINE GUARD (TB-270-240)
15	33-01-0025	1	EXHAUST TUBE GUARD
16	NC01-04-0001	5	CARR. BOLT GR2 ZINC 1/4-20 X 1/2"
17	NC01-96-0009	15	NYLON-INSERT LOCKNUT ZINC 1/4-20
18	33-46-0533	1	GAS HOSE 1/2" DIA.X 1/4" D.I. X 10"
19	NC13-65-0065	1	BARBED HOSE REDUCER 1/4" X 3/16"
20	33-46-0534	1	VENT HOSE 1/2" DIA.X 1/4" D.I. X 71 "
21	33-55-0040	1	HITCH ASSEMBLY
22	33-42-0005	1	90° PLASTIC ELBOW
23	33-01-2480	4	DUCT CLAMP
24	NC01-04-0005	8	CARR. BOLT GR2 ZINC 1/4-20 X 1"
25	33-50-2600	1	MICRO-SWITCH STOP
26	NC02-14-0017	1	FLANGED NUT GR. B 1/4-20
27	33-01-2410	1	CONTACT ROD HOLDER
28	NC02-22-0010	4	WASHER 13/32" ID
29	NC02-07-0018	8	HEX. NUT ZINC 3/8-16
30	NC01-04-0109	4	CARR. BOLT GR2 ZINC 3/8-16 X 1"
31	22-50-0300	1	MUFFLER SUPPORT (KOHLER 27 HP)
32	33-50-1050	1	27 HP KOHLER MUFFLER
33	NC02-25-0009	4	FLAT WASHER 14 GA X 13/16"OD X 25/64" ID
34	33-50-1055	1	MUFFLER GUARD (27 HP KOHLER)
35	NC02-32-0010	4	LOCK WASHER ZINC 1/4"
36	NC01-29-0003	4	HEX. BOLT GR5 ZINC 1/4-28 X 5/8"

## 33-55-0125

#	PART #	QTY	TITLE
37	NC14-70-0320	1	RIM FOR NC14-70-0317
38	NC14-55-0330	2	6205-2RSI BEARING
39	NC14-70-0322	1	VALVE FOR NC14-70-0317
40	NC14-70-0319	1	WHEEL 18X9.50-8 (TURBINE)
41	33-10-0015	1	INSIDE WHEEL SPACER

#	PART #	QTY	TITLE
1	33-22-2240	1	WIRE PROTECTOR
2	NC02-42-0096	4	PHILLIPS SCREW ZINC #14 X 5/8"
3	NC13-25-0019	12	BLACK TIE RAP
4	NC13-25-0375	1	67" NEW BOX WIRE
5	NC13-25-0370	1	ELECTRIC BOX
6	33-57-0076	1	REMOTE CONTROL GROUP.
7	NC13-25-0251	2	MICRO SWITCH BODY
8	NC13-25-0252	2	MICRO SWITCH HEAD
9	NC13-25-0253	2	MICRO SWITCH ROD ADAPTOR
10	NC13-25-0012	2	CONNECTOR "SKINTIGHT" (NYLON) 1/2 NPT X 0.200-0.470"
11	NC02-40-0081	4	SCREW ZINC 10-24 X 5/8"
12	NC01-96-0006	4	NYLON NUT ZINC 3/16
13	33-55-0515	1	18 GA ELECTRIC WIRE 600V (MICRO SWITCH) ASSY.
14	NC13-25-0233	2	VINYLE PROTECTOR COLLAR

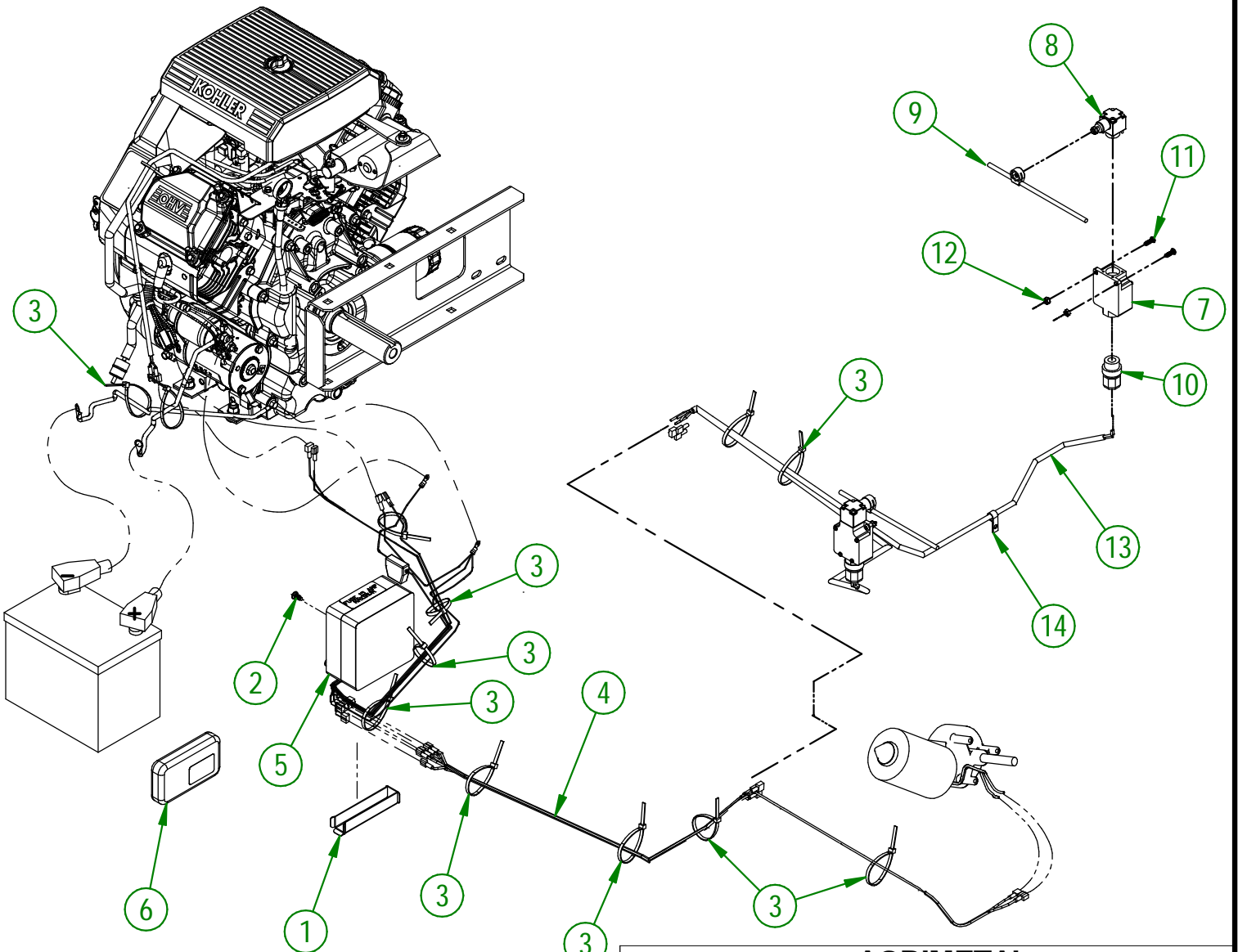

**AGRIMETAL**  
**TURBINE BLOWER 270 IC**

CREATION : 13/02/24	ASSEMBLY : <b>33-99-2600</b>
REVISION : 23/02/24	AUTHOR : J. Houle

TURBINE BLOWER 270 IC  
TURBINE BLOWER 350 IC

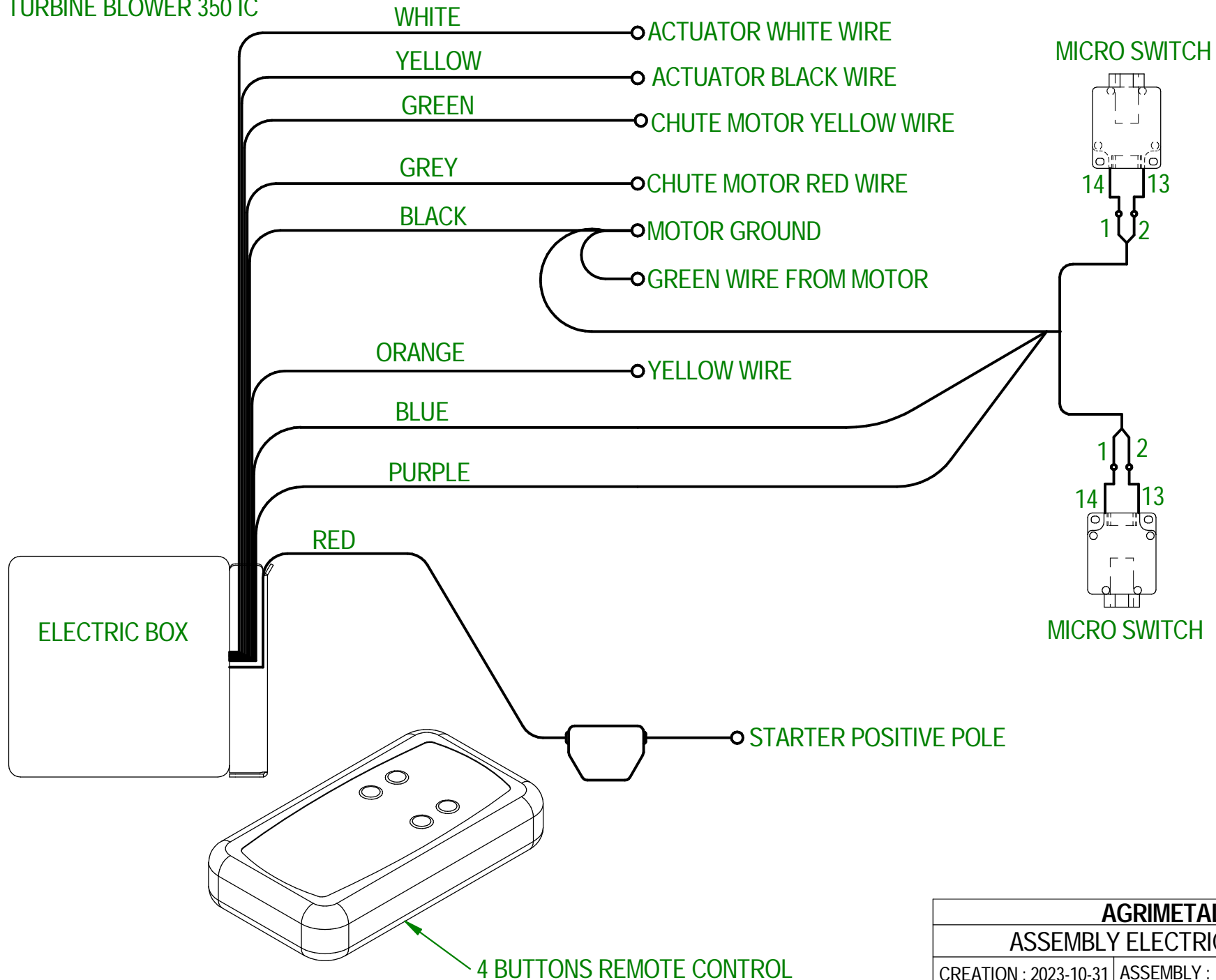

<b>AGRIMETAL</b>	
<b>ASSEMBLY ELECTRIC CONTROL</b>	
CREATION : 2023-10-31	ASSEMBLY : <b>33-57-0506</b>
REVISION : 2024-02-12	AUTHOR : D. CHASSÉ

33-57-0506

#	PART #	Qty	TITLE
1	33-22-2240	1	WIRE PROTECTOR
2	NC02-42-0096	4	PHILLIPS SCREW ZINC #14 X 5/8"
3	NC13-25-0370	1	ELECTRIC BOX TB 380
4	NC13-33-0227	1	STICKER FUSE 15 AMP MAXIMUM
5	NC13-25-0375	1	67" NEW BOX WIRE
6	NC13-25-0019	10	BLACK TIE RAP

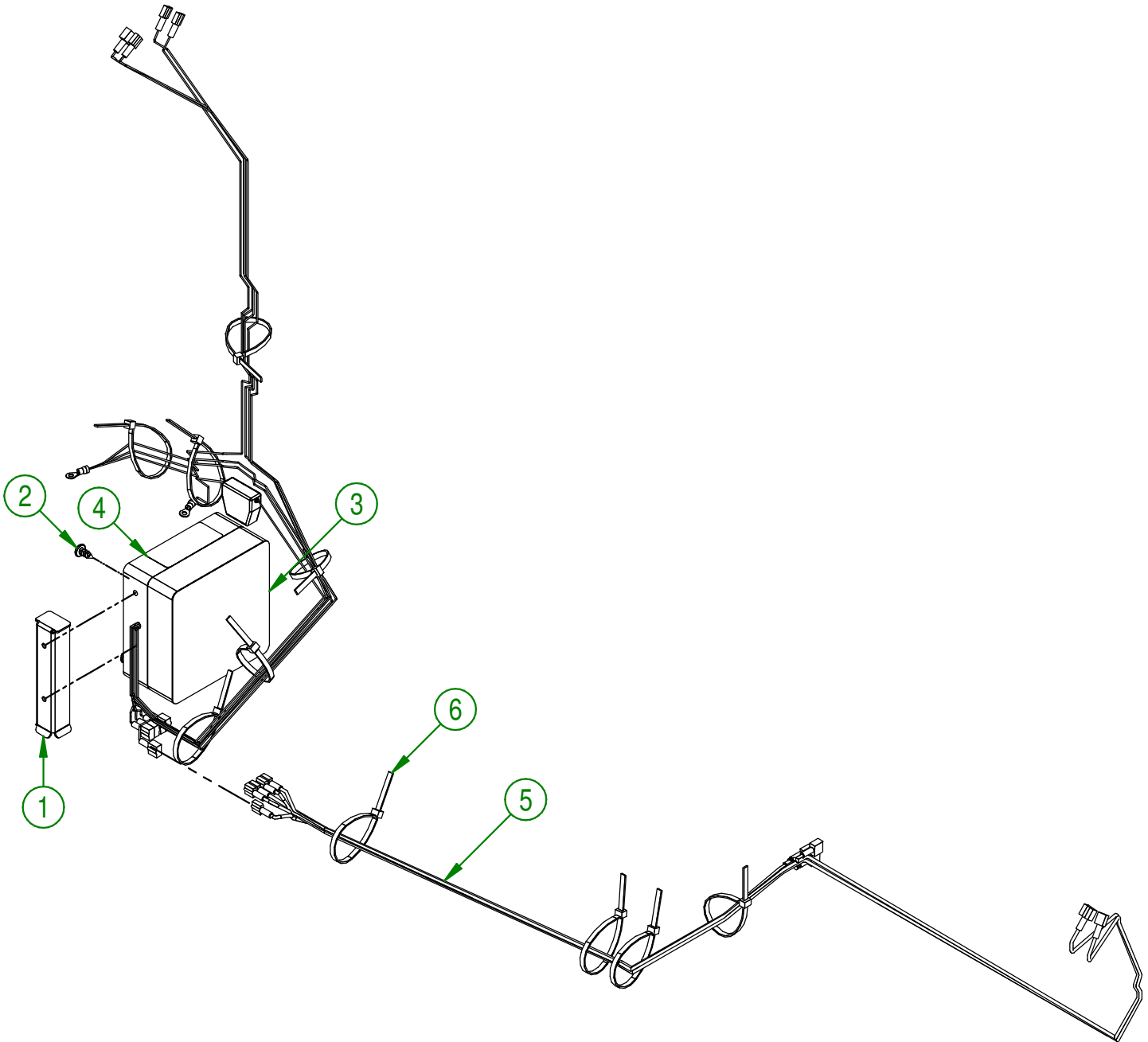

<b>AGRIMETAL</b>	
<b>ASSEMBLY ELECTRIC CONTROL</b>	
CREATION : 24/11/21	ASSEMBLY : 33-57-0506
REVISION : 24/11/21	AUTHOR : S.R.

#	PART #	Qty	TITLE
1	33-01-3045	2	GAS TANK STRAP
2	33-46-0532	1	GAS HOSE 1/2" DIA.X 1/4" D.I. X 37"
3	NC01-04-0002	4	CARR. BOLT GR2 ZINC 1/4-20 X 5/8"
4	NC01-65-0201	2	SPRING -GRIP HOSE CLAMPS 1/2" O.D
5	NC01-96-0009	4	NYLON-INSERT LOCKNUT ZINC 1/4-20
6	NC13-80-0247	1	GAS CAP
7	NC13-80-0265	1	GROMMET VITRON #468661
8	NC13-80-0266	1	1/4" ON-OFF GAS VALVE

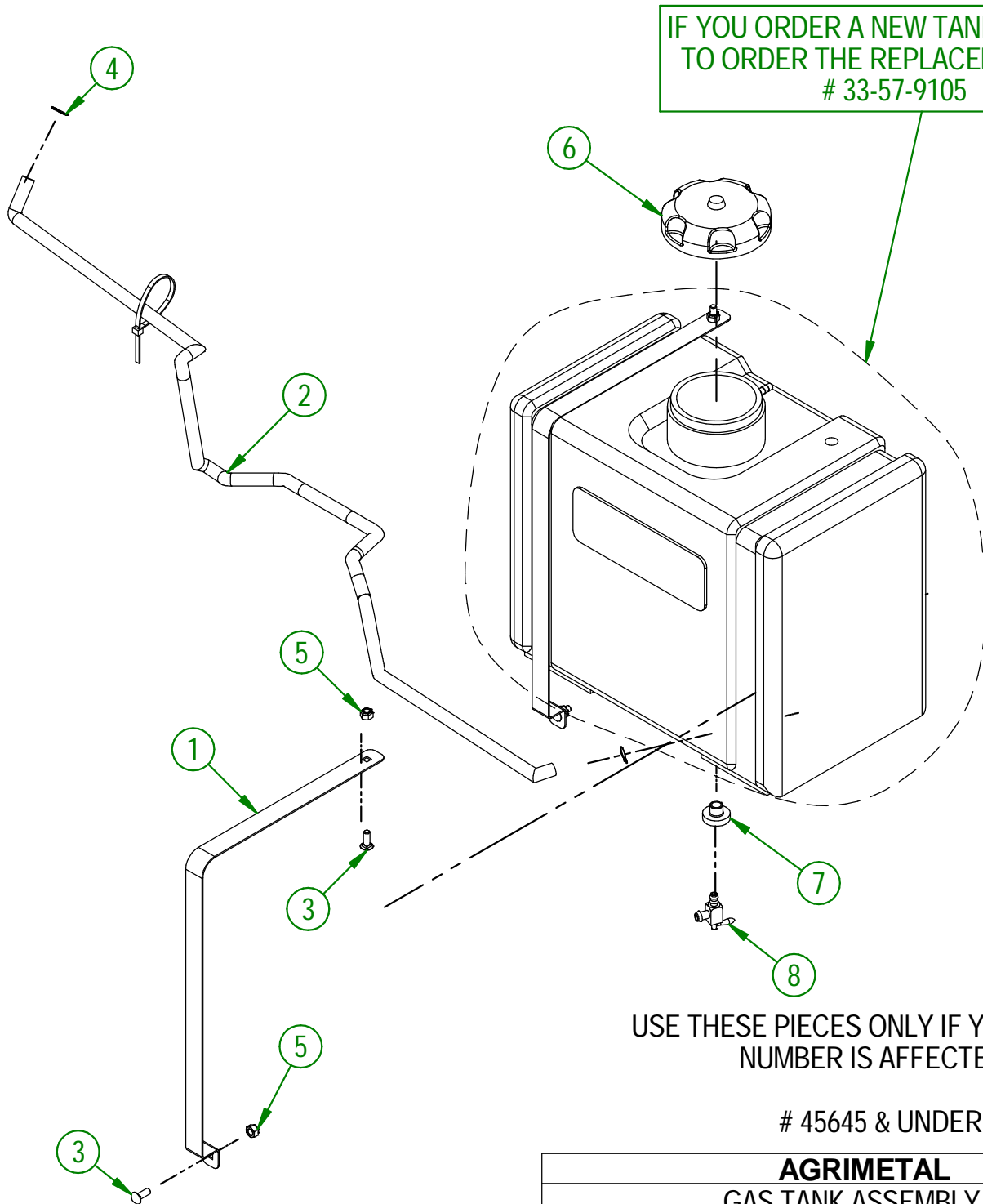

IF YOU ORDER A NEW TANK YOU HAVE TO ORDER THE REPLACEMENT KIT # 33-57-9105

USE THESE PIECES ONLY IF YOUR SERIAL NUMBER IS AFFECTED:

# 45645 & UNDER

<b>AGRIMETAL</b>	
<b>GAS TANK ASSEMBLY</b>	
CREATION : 28/05/24	ASSEMBLY : <b>33-57-0130</b>
REVISION : 28/05/24	AUTHOR : J.KABWE

#	PART #	Qty	TITLE
1	33-55-0200	1	GAS TANK
2	33-01-3045	2	GAS TANK STRAP
3	33-46-0545	1	GAS HOSE 1/2" DIA.X 1/4" D.I. X 50"
4	NC01-04-0002	2	CARR. BOLT GR2 ZINC 1/4-20 X 5/8"
5	NC01-07-0002	2	CARR. BOLT GR5 ZINC 1/4-20 X 5/8"
6	NC01-96-0009	4	NYLON-INSERT LOCKNUT ZINC 1/4-20
7	NC01-65-0201	2	SPRING -GRIP HOSE CLAMPS 1/2" O.D
8	NCI3-25-0019	3	BLACK TIE RAP
9	33-55-0205	1	GAS CAP

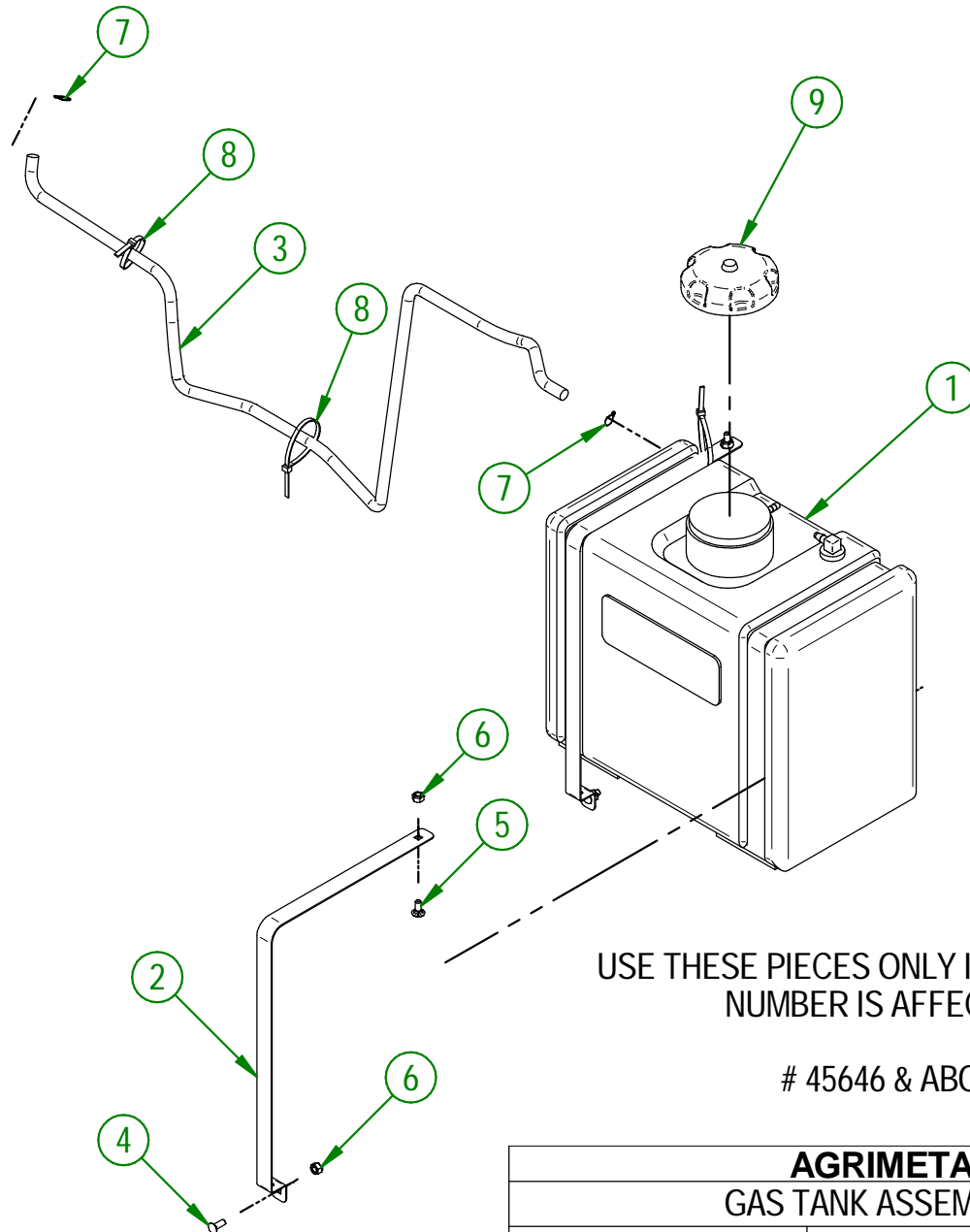

USE THESE PIECES ONLY IF YOUR SERIAL NUMBER IS AFFECTED:

# 45646 & ABOVE

<b>AGRIMETAL</b>	
<b>GAS TANK ASSEMBLY</b>	
CREATION : 15/05/24	ASSEMBLY : <b>33-57-0165</b>
REVISION : 18/02/26	AUTHOR : D. CHASSÉ

33-57-2520

#	PART #	Qty	TITLE
1	NC01-37-0263	4	HEX. BOLT GR8 NF ZINC 1/2-20 X 5" LG
2	NC02-22-0012	4	WASHER ZINC 1/2 BOLT = 9/16"Ø X 1 3/8" OD
3	NC01-94-0013	4	NYLON NUT ZINC 1/2-20"
4	33-57-2501	1	ASSEMBLY FRAME STICKER INCLUDED
5	33-57-0215	1	ENGINE BASE GROUP
6	33-01-0335	1	SHIELD PLATE
7	NC01-07-0107	2	CARR. BOLT GR2 ZINC 3/8-16 X 3/4"
8	01-01-2485	2	FLAT WASHER 14 GA X 13/16"OD X 25/64" ID
9	NC01-93-0011	2	LOCK NUT 3/8-16

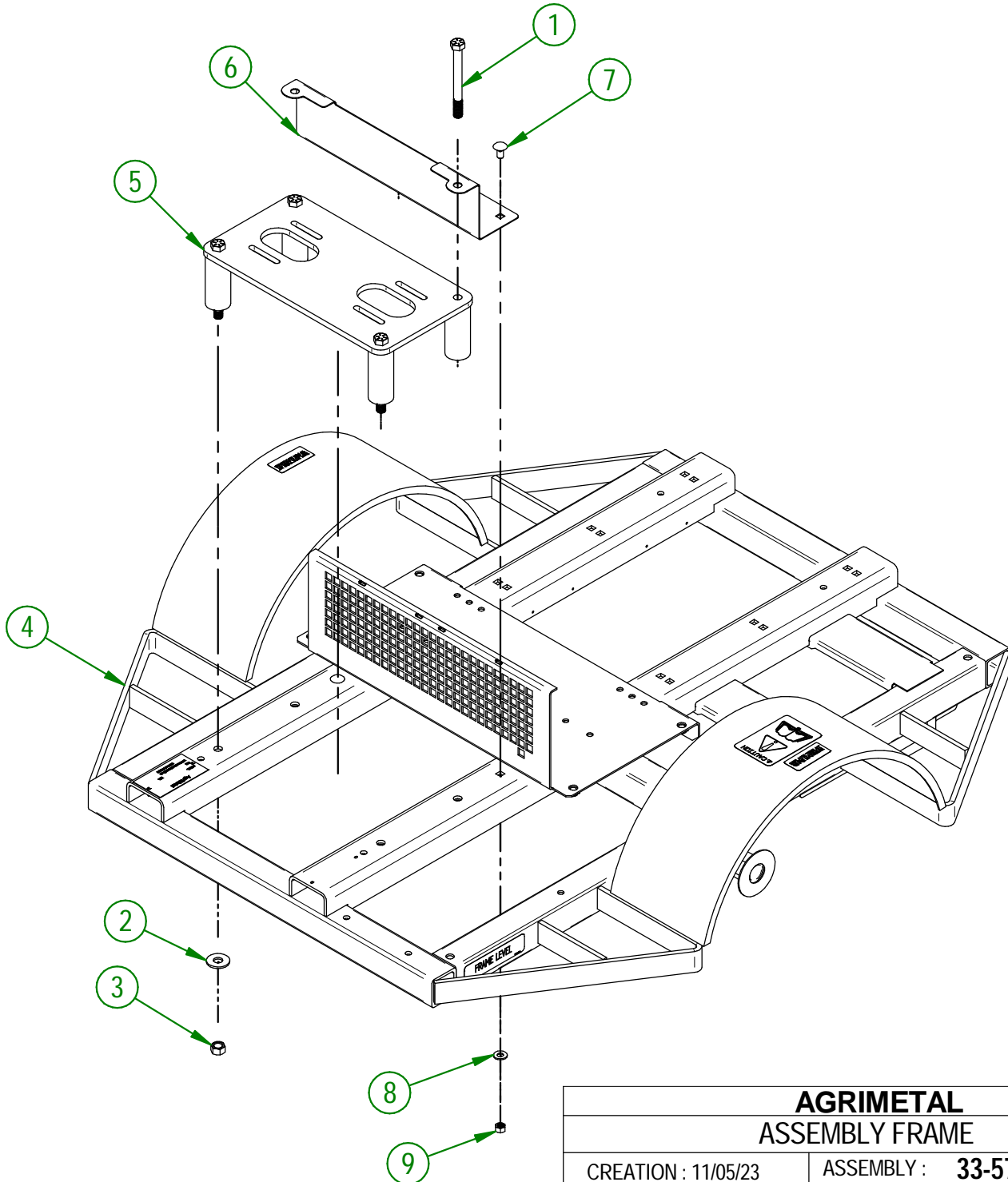

<b>AGRIMETAL</b>	
<b>ASSEMBLY FRAME</b>	
CREATION : 11/05/23	ASSEMBLY : <b>33-57-2520</b>
REVISION : 25/06/24	AUTHOR : D. CHASSÉ

#	PART#	QTY	TITLE
1	33-50-0010	1	DRAW BAR
2	33-04-0605	1	HITCH PLATE
3	NC01-17-0123	2	HEX. BOLT GR2 ZINC 3/8-16 X 3 1/4"
4	NC02-32-0012	2	LOCK WASHER ZINC 3/8"
5	NC02-07-0018	2	HEX. NUT ZINC 3/8-16
6	NC02-25-0011	8	WASHER SAE ZINC 17/32 ID
7	NC02-32-0014	4	LOCK WASHER ZINC 1/2"
8	NC02-07-0020	4	HEX. NUT ZINC 1/2-13
9	NC01-17-0259	4	HEX. BOLT GR2 ZINC 1/2-13 X 4"
10	NC01-17-0116	1	HEX. BOLT GR2 ZINC 3/8-16 X 1 1/2"
11	NC02-22-0010	4	WASHER 13/32" ID
12	55-41-0000	1	SAFETY CHAIN
13	NC01-96-0011	1	NYLON NUT 3/8-16
14	23-50-0045	1	HITCH HAND
15	NC13-80-0290	1	2" HITCH BALL COUPLER
16	NC02-25-0011	2	WASHER SAE ZINC 17/32 ID
17	NC01-93-0014	2	LOCK NUT ZINC 1/2-13
18	NC01-25-0257	2	HEX. BOLT GR5 ZINC 1/2-13 X 3 1/2"
19	23-09-0100	1	HITCH SPACER
20	NC02-22-0012	2	WASHER ZINC 1/2 BOLT = 9/16"Ø X 1 3/8" OD

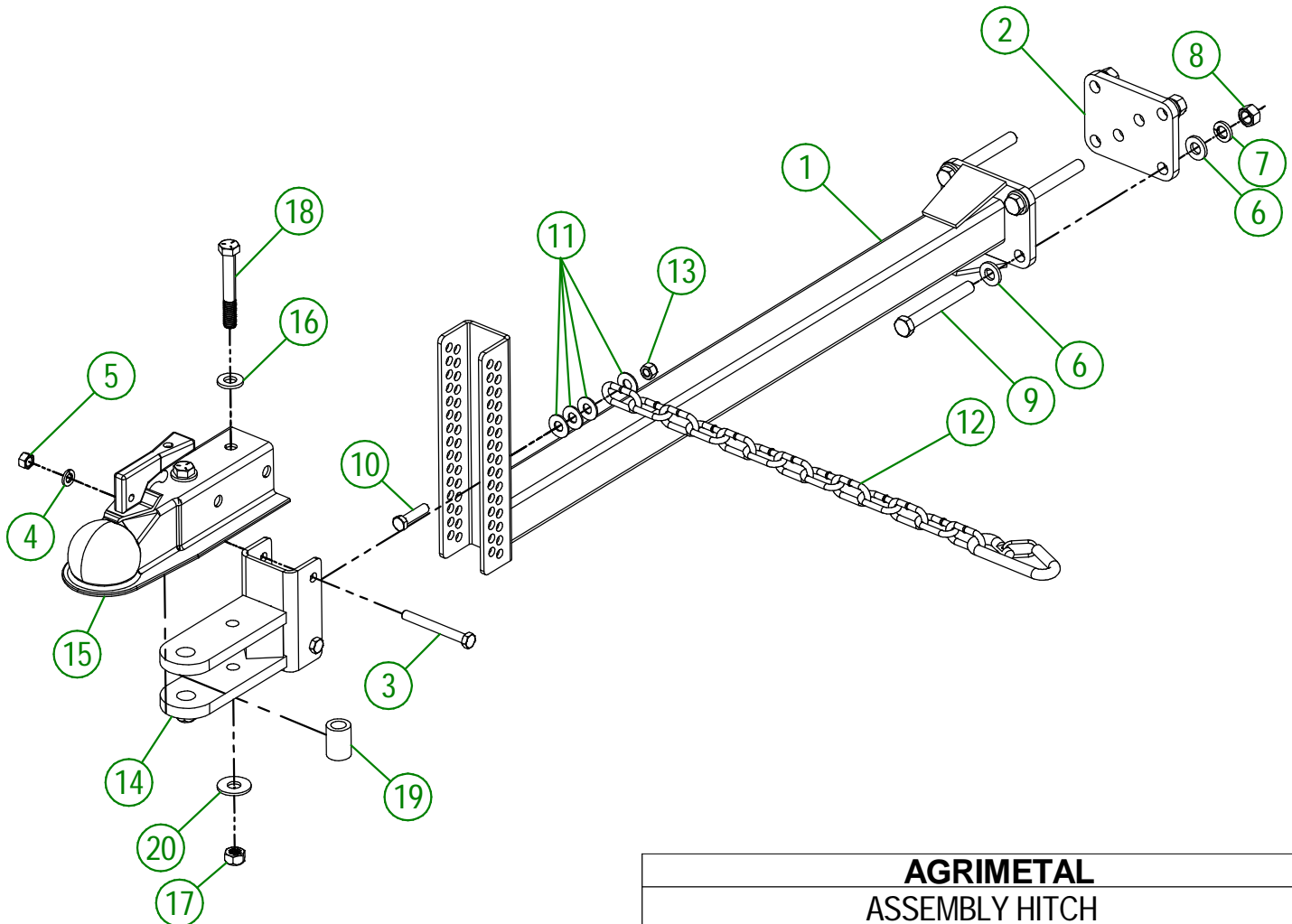

<b>AGRIMETAL</b>	
<b>ASSEMBLY HITCH</b>	
CREATION : 16/10/24	ASSEMBLY : <b>33-55-0040</b>
REVISION : 29/04/25	AUTHOR : J.KABWE

33-57-2541

#	PART #	Qty	TITLE
1	NC01-02-0112	4	CARR. BOLT GR2 FLZ 3/8-16 X 1 3/4"
2	01-01-2485	4	FLAT WASHER 14 GA X 13/16"OD X 25/64" ID
3	NC02-32-0012	8	LOCK WASHER ZINC 3/8"
4	NC02-07-0018	8	HEX. NUT ZINC 3/8-16
5	33-22-2215	4	ENGINE SHIM ALU. 0.016" X 8.125" X 2"
6	33-22-5600	8	ENGINE STOPPER
7	NC01-04-0109	4	CARR. BOLT GR2 ZINC 3/8-16 X 1"

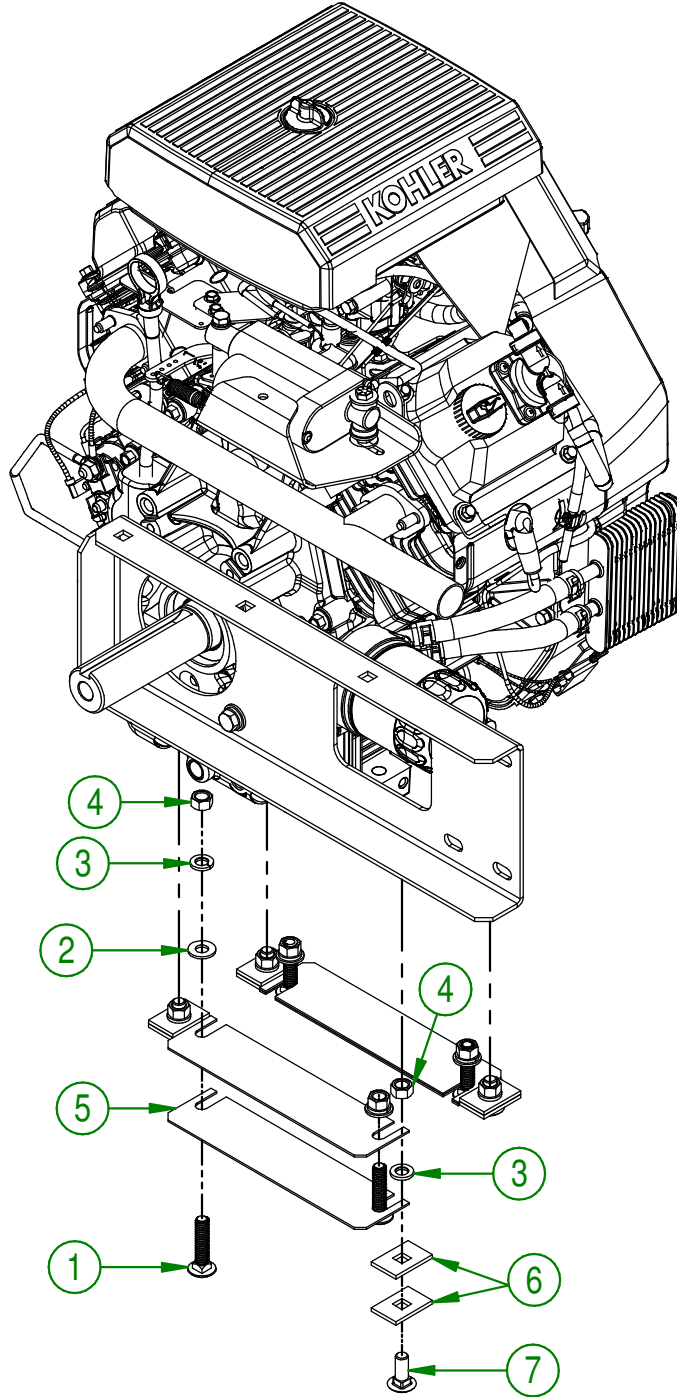

<b>AGRIMETAL</b>	
<b>27 HP ENGINE GROUP.</b>	
CREATION : 01/11/17	ASSEMBLY : <b>33-57-2541</b>
REVISION : 12/10/18	AUTHOR : J.KABWE

#	PART #	QTY	TITLE
1	33-01-0900	1	MOFFLER SUPPORT
2	33-35-5000	1	EXHAUST MANIFOLD
3	33-01-0040	1	ACTUATOR SUPPORT
4	NC01-37-0008	1	HEX. BOLT GR8 1/4-28 X 1 1/2"
5	NC01-37-0006	1	HEX BOLT GR8 NF ZINC 1/4-28 X 1
6	33-21-0070	1	ACTUATOR SUPPORT BUSHING
7	33-21-0075	1	ACTUATOR SUPPORT BUSHING
8	NC01-97-0004	2	NYLON-INSERT LOCKNUT ZINC 1/4-28
9	33-01-0425	1	ACTUATOR SUPPORT
10	01-01-2485	4	FLAT WASHER 14 GA X 13/16"OD X 25/64" ID
11	NC02-32-0012	4	LOCK WASHER ZINC 3/8"
12	NC01-25-0114	4	HEX. BOLT GR5 ZINC 3/8-16 X 1"
13	33-55-1505	1	ASSEMBLY BATTERY RED CABLE #4
14	33-55-2500	1	ASSEMBLY BATTERY BLACK CABLE #4
15	NC13-25-0110	1	SNUG-FIT DAMPING LOOP CLAMP
16	33-46-0527	1	1/4" GAS HOSE
17	NC01-45-0062	1	METR. BOLT GR 8.8 4MM X0.70P X 40MM

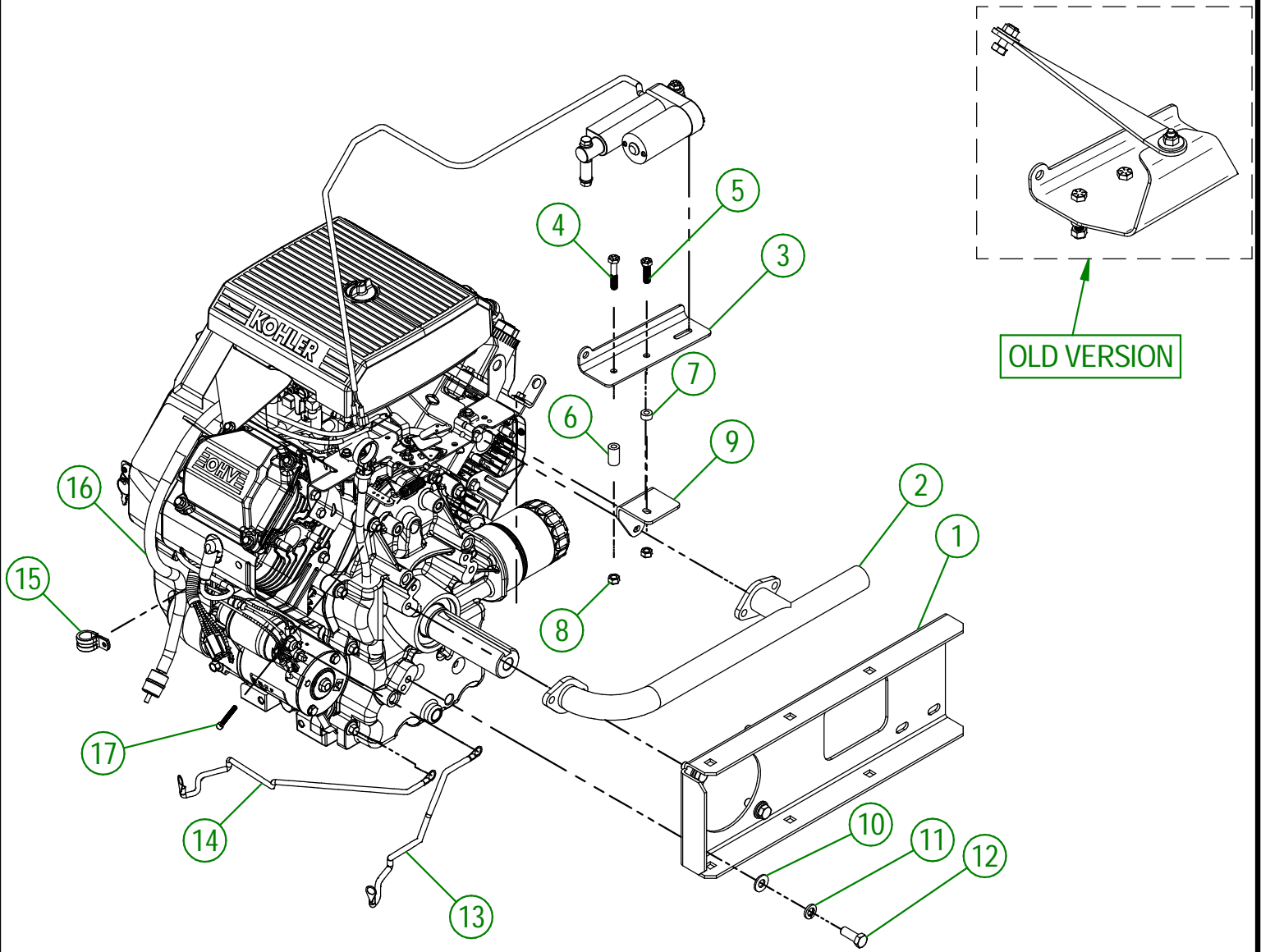

<b>AGRIMETAL</b>	
<b>27 HP KOHLER ENGINE STARTER ASSY.</b>	
CREATION : 01/11/17	ASSEMBLY : <b>33-55-2531</b>
REVISION : 07/07/25	AUTHOR : J.KABWE

MACHINE: TURBINE BLOWER 270

#	PART #	Qty	TITLE
1	33-55-0100	1	ACTUATOR 12 VOLTS
2	33-57-0107	1	ACTION ROD
3	NC01-37-0011	1	HEX. BOLT GR8 1/4-28 X 2 1/4
4	33-42-0120	2	PIVOT BUSHING
5	NC02-14-1200	1	TWO WAY LOCK NUT 1/4-28
6	NC02-25-0007	4	WASHER ZINC 0.281 = 9/32
7	36-01-2430	2	FLAT WASHER 14GA X 17/64" I.D. X 13/16" O.D.
8	NC01-97-0004	1	NYLON-INSERT LOCKNUT ZINC 1/4-28

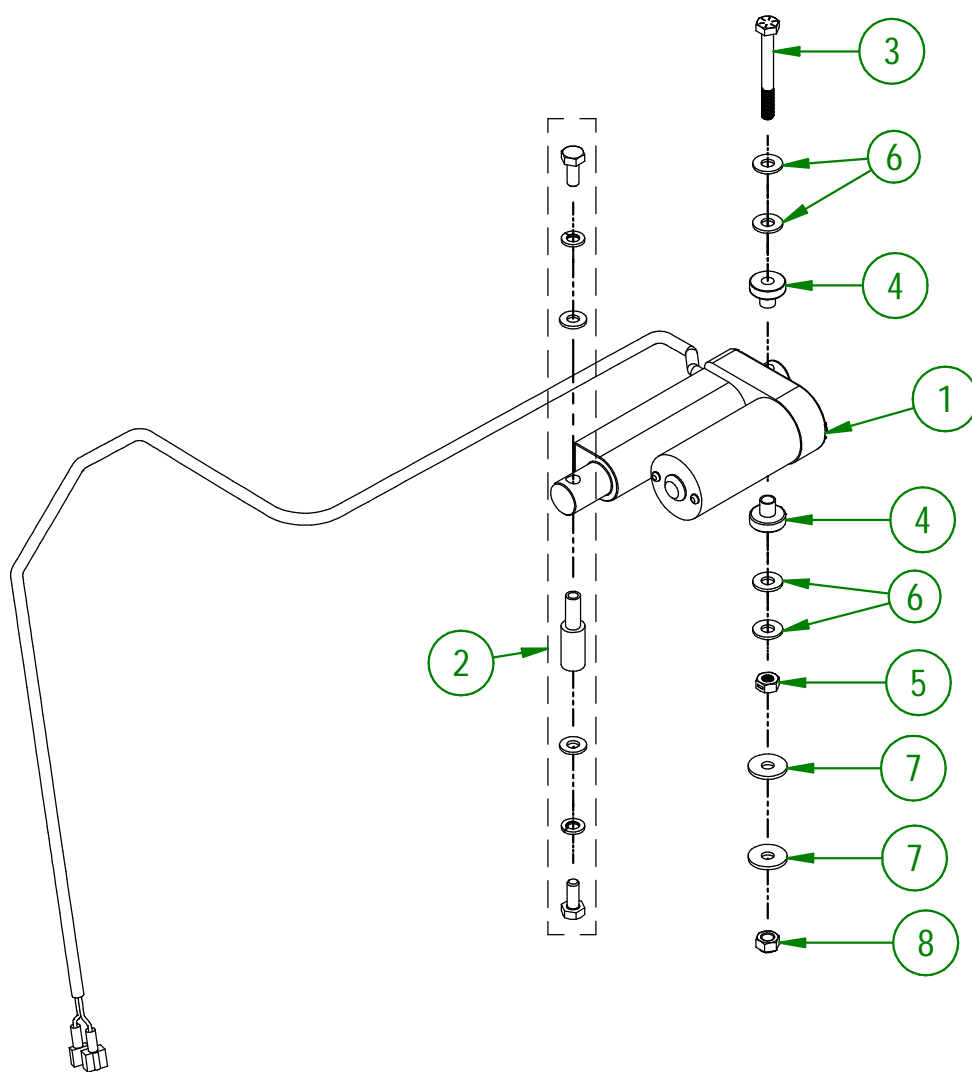

<b>AGRIMETAL</b>	
<b>ASSEMBLY ACTUATOR 12 VOLTS</b>	
CREATION : 17/04/18	ASSEMBLY : <b>33-55-0107</b>
REVISION : 12/05/23	AUTHOR : J.KABWE

#	PART #	Qty	TITLE
1	33-04-1600	2	FLANGE
2	33-21-0055	4	SLEEVE
3	01-01-0925	4	WASHER
4	33-01-7570	2	WASHER
5	NC14-62-0016	1	QD BUSHING SH I 1/4"
6	NC14-62-0211	1	QD BUSHING SH I 7/16"
7	33-20-0152	2	SPACER
8	NC01-37-0253	4	HEX. BOLT GR8 ZINC 1/2-20 X 2 1/2"
9	NC01-94-0013	4	NYLON NUT ZINC 1/2-20"
10	33-41-0920	1	SQUARE KEY

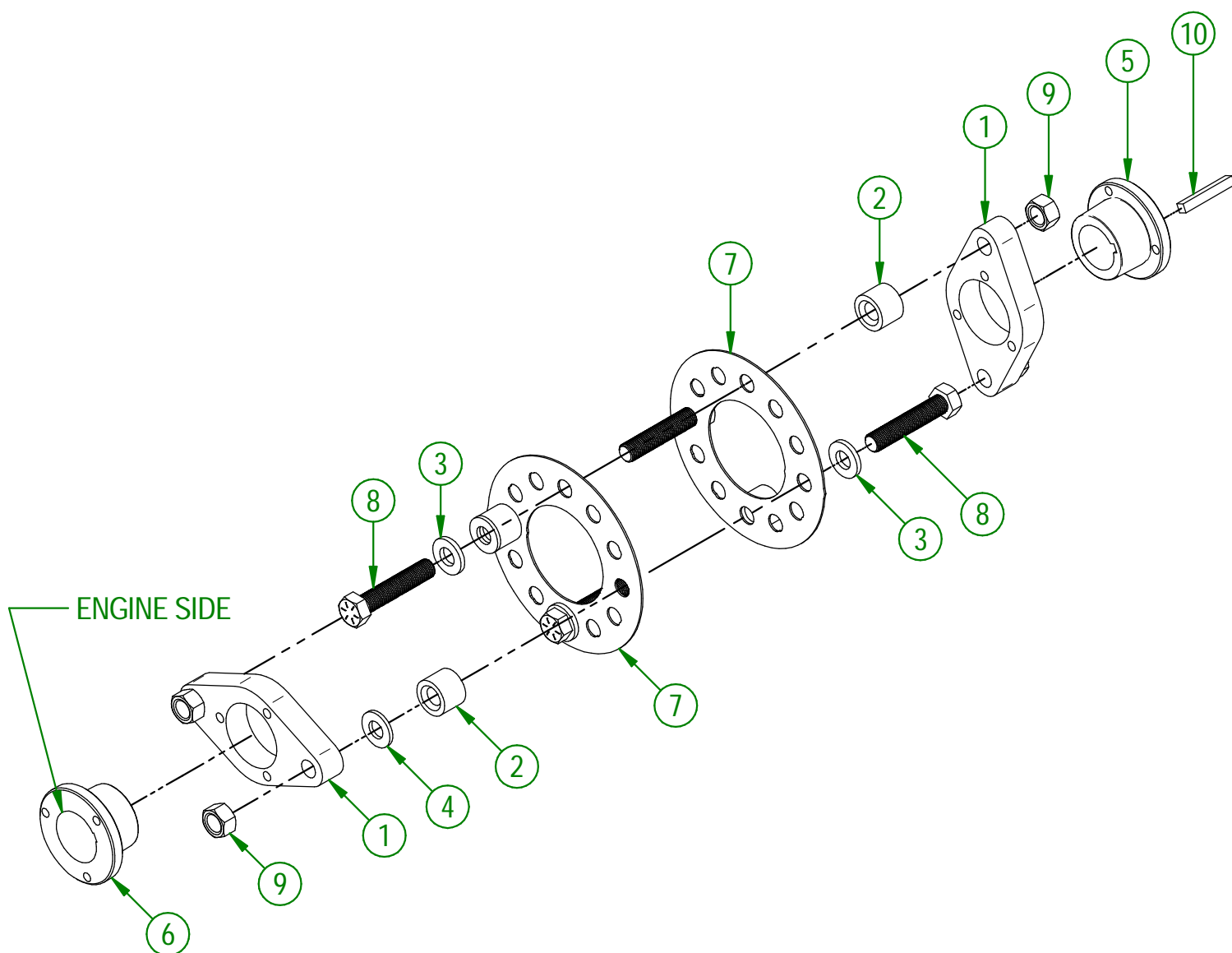

**AGRIMETAL**  
**COUPLING ASSEMBLY**

CREATION : 03/11/17  
 REVISION : 09/11/23

ASSEMBLY : **33-57-0046**  
 AUTHOR : J.KABWE

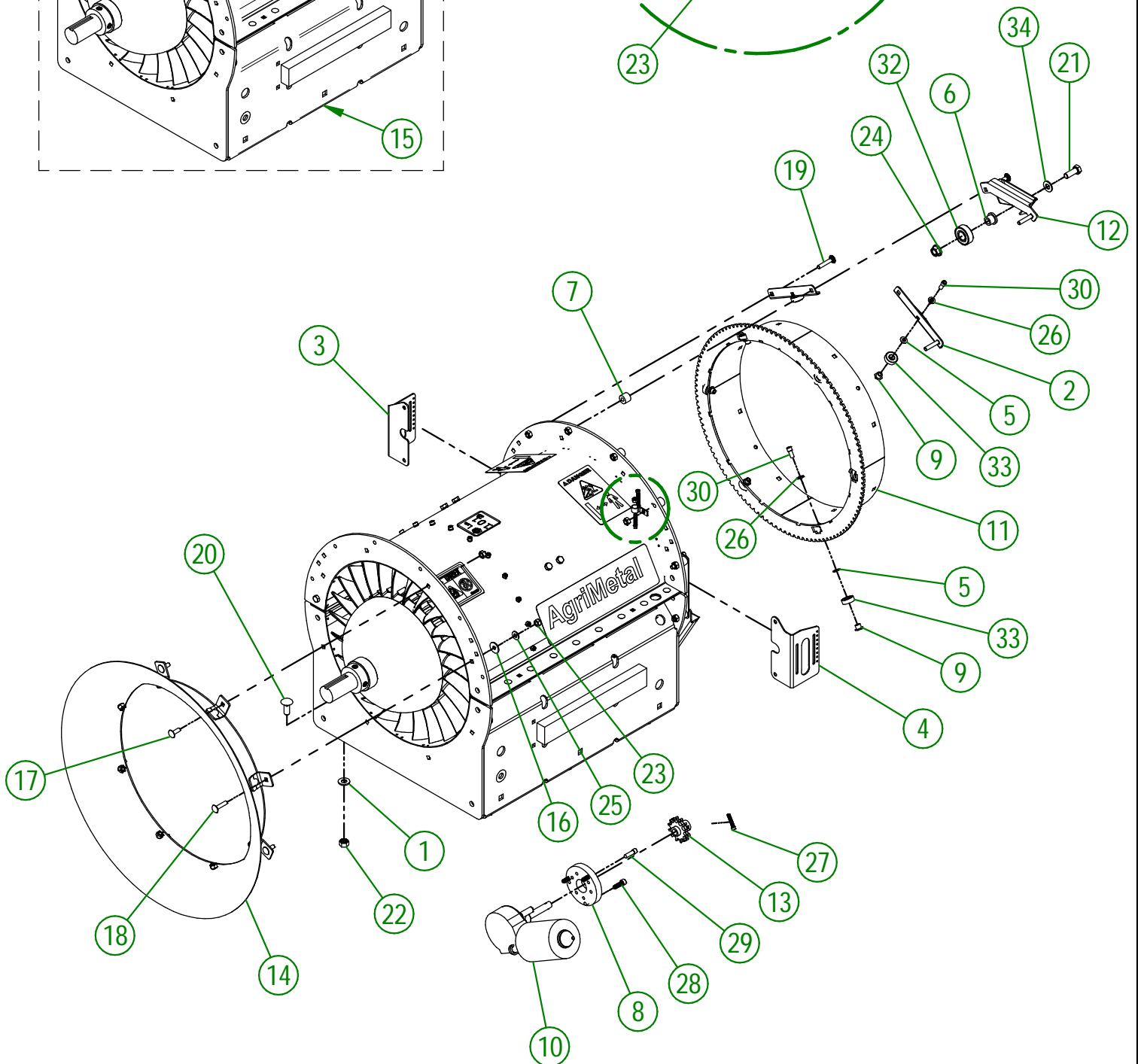
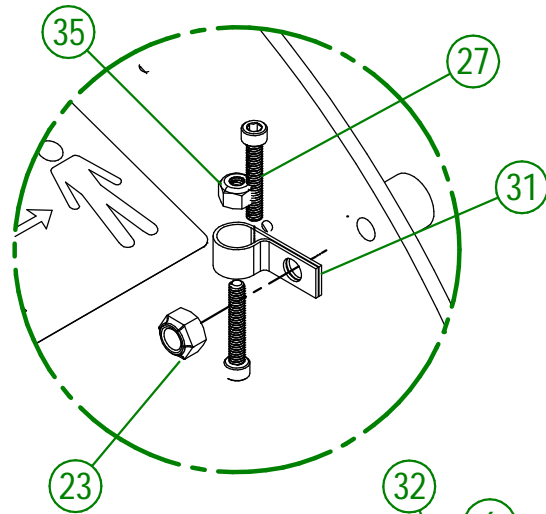
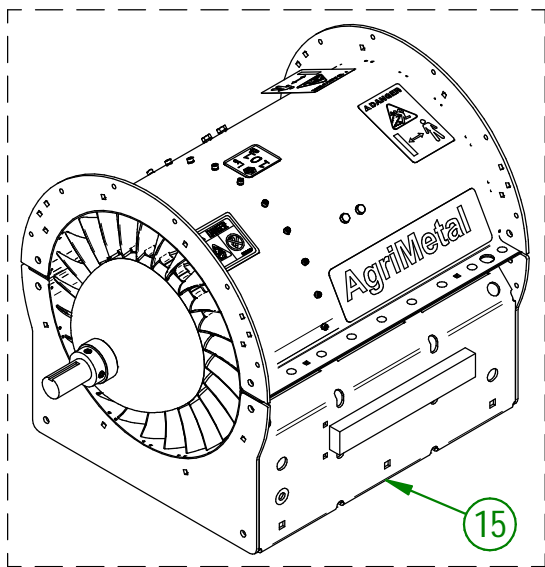

**AGRIMETAL**  
**TURBINE**

CREATION : 14/06/24  
REVISION : 12/05/25

ASSEMBLY : **33-57-0135**  
AUTHOR : J. Houle

#	PART #	Qty	TITLE
1	01-01-2485	6	FLAT WASHER 14 GA X 13/16"OD X 25/64" ID
2	33-01-2425	6	BEARING HOLDER BRACKET
3	33-01-2450	1	RIGHT MICRO SWITCH SUPPORT
4	33-01-2452	1	LEFT MICRO SWITCH SUPPORT
5	33-03-4605	12	BEARING SHIM 1/4" ALUMINUM
6	33-21-0060	3	BEARING HOLDER
7	33-21-0080	12	SPACER
8	33-21-0100	1	ENGINE CONVERSION PLATE
9	33-25-2410	12	BEARING BUSHING
10	33-35-0005	1	OUTLET MOTOR
11	33-50-0015	1	DUCT COLECTOR
12	33-50-0555	3	WELD ASSEMBLY BEARING SUPPORT
13	33-50-2002	1	CROWN PINION
14	33-55-0085	1	AIR INTAKE ASSY.
15*	33-57-0020	1	TURBINE KIT (NEW)
16	36-01-2430	3	FLAT WASHER 14GA X 17/64" I.D. X 13/16" O.D.
17	NC01-04-0003	6	CARR. BOLT GR2 ZINC 1/4-20 X 3/4"
18	NC01-04-0005	2	CARR. BOLT GR2 ZINC 1/4-20 X 1"
19	NC01-04-0006	12	CARR. BOLT GR2 ZINC 1/4-20 X 1 1/4"
20	NC01-04-0109	6	CARR. BOLT GR2 ZINC 3/8-16 X 1"
21	NC01-17-0114	3	HEX. BOLT GR2 ZINC 3/8-16 X 1"
22	NC01-93-0011	6	LOCK NUT 3/8-16
23	NC01-96-0009	21	NYLON-INSERT LOCKNUT ZINC 1/4-20
24	NC02-14-0019	3	FLANGE NUT HEX. NC 3/8-16 GR. B
25	NC02-25-0007	2	WASHER ZINC 0.281 = 9/32
26	NC02-32-0010	12	LOCK WASHER ZINC 1/4"
27	NC02-50-0069	3	SOCKET CAP SCREW T.RON 8-32 X 1"
28	NC02-50-1072	3	SOCKET CAP SCREW M6 X 20mm
29	NC02-51-0080	3	SOCKET CAP SCREW T.RON 1/4-28 X 3/4"
30	NC02-51-0578	12	SOCKET CAP SCREW T.RON. NF 1/4-28 X 1/2 STAINLESS
31	NC13-25-0233	1	VINYLE PROTECTOR COLLAR
32	NC14-75-0068	3	BALL BEARING 99502H
33	NC14-75-0153	12	BALL BEARING R6 2RS 3/8" X 7/8" X 0.281"
34	NC02-25-0009	3	FLAT WASHER 14 GA X 13/16"OD X 25/64" ID
35	NC01-96-0004	3	8-32 JAM NUT

#	PART #	Qty	TITLE
1	NC01-96-0009	2	NYLON-INSERT LOCKNUT ZINC 1/4-20
2	NC01-04-0027	2	CARR. BOLT 1/4-20 X 6" LG
3	NC01-04-0056	2	CARR. BOLT 5/16-18 X3/4"
4	33-01-3015	1	BATTERY STRAPE
5	NC02-32-0011	2	LOCK WASHER ZINC 5/16"
6	NCI3-12-0001	1	12 VOLTS BATTERY
7	NC02-07-0017	2	HEX. NUT 5/16-18
8	NCI3-80-0267	1	RED PROTECTOR FOR BATTERY POST
9	NCI3-80-0268	1	BLACK PROTECTOR FOR BATTERY POST
10	33-01-4000	1	HOUR METER HOLDER
11	NCI3-37-0669	1	HOUR METER

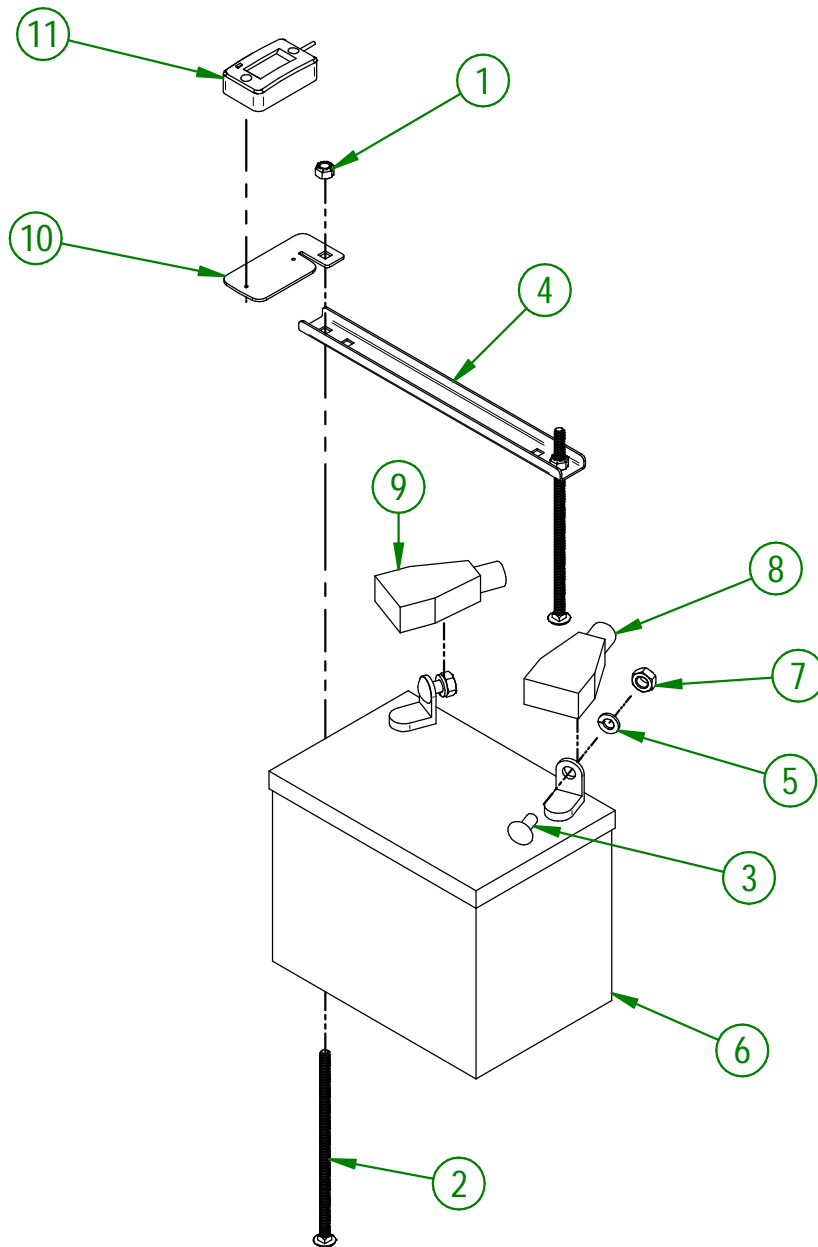

USE THESE PIECES ONLY IF YOUR SERIAL NUMBER IS AFFECTED:

BELOW # 44661

<b>AGRIMETAL</b>	
12 VOLTS BATTERY GROUP.	
CREATION : 31/10/17	ASSEMBLY : <b>33-57-0055</b>
REVISION : 11/09/23	AUTHOR : J.KABWE

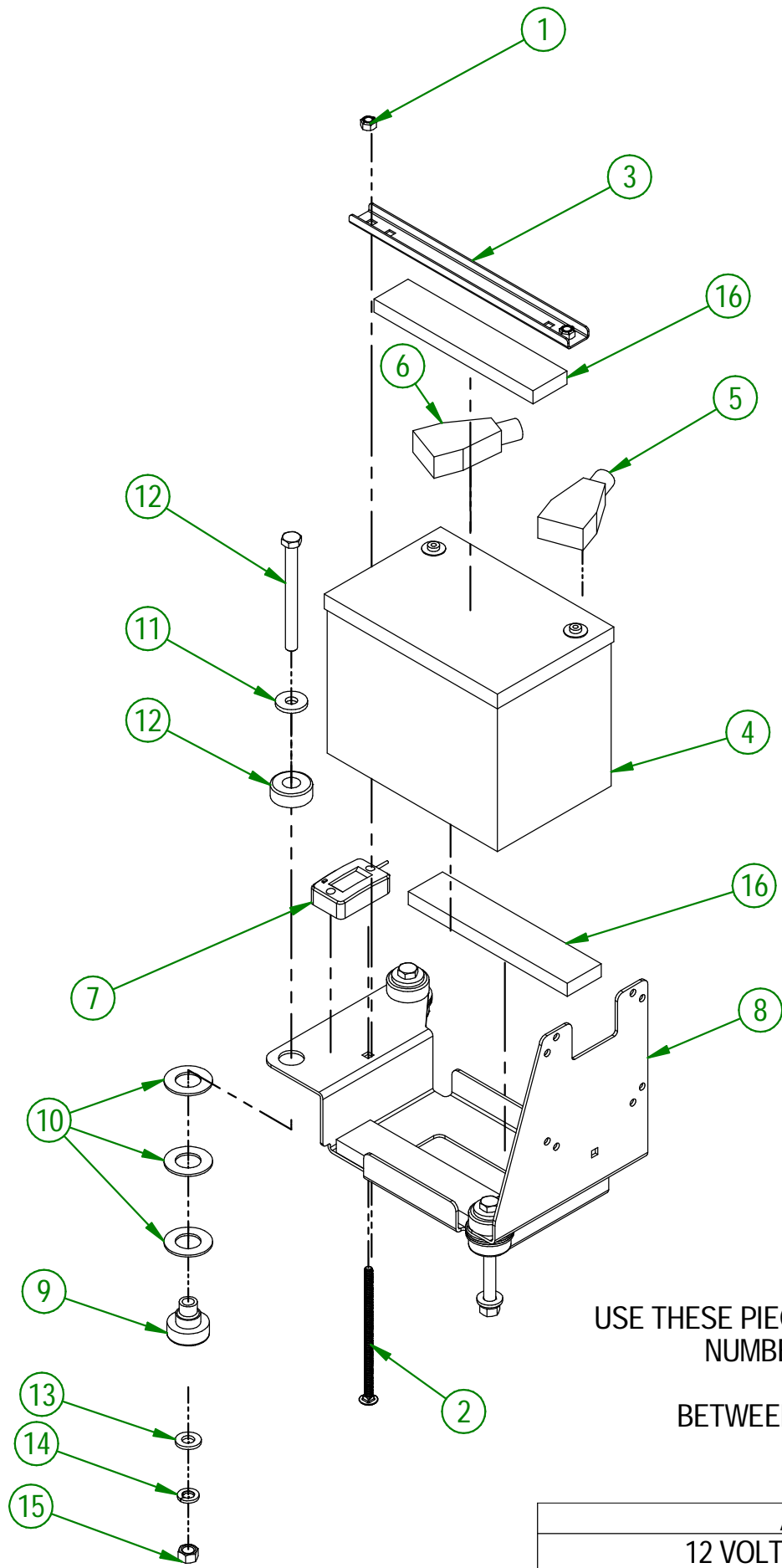

USE THESE PIECES ONLY IF YOUR SERIAL NUMBER IS AFFECTED:

BETWEEN #44661 & #45502

<b>AGRIMETAL</b>	
12 VOLTS BATTERY GROUP.	
CREATION : 29/08/23	ASSEMBLY : <b>33-57-0057</b>
REVISION : 30/05/25	AUTHOR : D. CHASSÉ

## 33-57-0057

#	PART #	Qty	TITLE
1	NC01-96-0009	2	NYLON-INSERT LOCKNUT ZINC 1/4-20
2	NC01-04-0024	2	CARR. BOLT GR2 ZINC 1/4-20 X 5"
3	33-01-3015	1	BATTERY STRAPE
4	NC13-12-0017	1	12 VOLTS GEL BATTERY
5	NC13-80-0267	1	RED PROTECTOR FOR BATTERY POST
6	NC13-80-0268	1	BLACK PROTECTOR FOR BATTERY POST
7	NC13-37-0669	1	HOUR METER
8	33-57-2400	1	BATTERY SUPPORT PLATE "INCL. STICKER"
9	NC13-15-0354	3	RED RUBBER BASE MOUNT
10	26-03-4800	9	WASHER
11	21-01-0950	3	FLAT WASHER 10GA 1.005" DIA X 25/64"
12	NC01-25-0126	3	HEX. BOLT GR5 ZINC 3/8-16 X 4"
13	NC02-25-0009	3	WASHER 0.406" I.D. X 0.815 O.D.
14	NC02-32-0012	3	LOCK WASHER ZINC 3/8"
15	NC02-07-0018	3	HEX. NUT ZINC 3/8-16
16	33-42-0130	3	BLACK ADHESIVE-BACK STRIP

#	PART #	Qty	TITLE
1	NCI3-12-0017	1	12 VOLTS GEL BATTERY
2	NCI3-80-0267	1	RED PROTECTOR FOR BATTERY POST
3	NCI3-80-0268	1	BLACK PROTECTOR FOR BATTERY POST
4	NCI3-37-0669	1	HOUR METER
5	33-57-2401	1	BATTERY SUPPORT PLATE "INCL. STICKER"
6	NCI3-15-0354	3	RED RUBBER BASE MOUNT
7	26-03-4800	9	WASHER
8	21-01-0950	3	FLAT WASHER 10GA 1.005" DIA X 25/64"
9	NC01-25-0126	3	HEX. BOLT GR5 ZINC 3/8-16 X 4"
10	NC02-25-0009	3	WASHER 0.406" I.D. X 0.815 O.D.
11	NC02-32-0012	3	LOCK WASHER ZINC 3/8"
12	NC02-07-0018	3	HEX. NUT ZINC 3/8-16
13	33-42-0130	2	BLACK ADHESIVE-BACK STRIP
14	NCI3-15-0008	1	RUBBER STRAP
15	33-42-0135	2	BLACK ADHESIVE-BACK STRIP

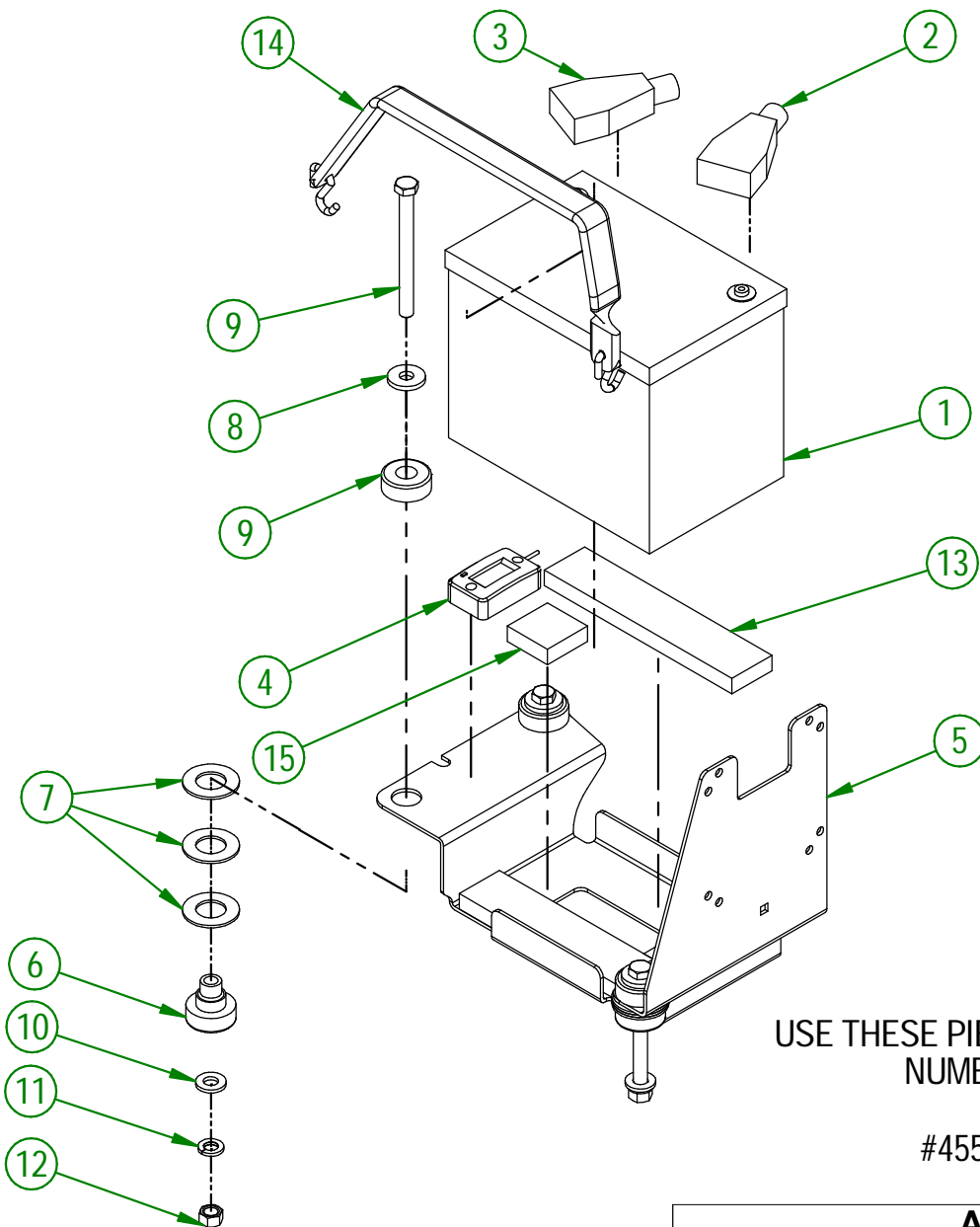

USE THESE PIECES ONLY IF YOUR SERIAL NUMBER IS AFFECTED:

#45503 AND ABOVE

<b>AGRIMETAL</b>	
12 VOLTS BATTERY GROUP.	
CREATION : 21/02/24	ASSEMBLY : <b>33-57-0170</b>
REVISION : 30/05/25	AUTHOR : D. CHASSÉ

33-57-2566

#	PART #	Qty	TITLE
1	NC13-30-0237	1	PLASTIC TUBE FOR OPERATOR'S MANUAL
2	NC01-04-0003	3	CARR. BOLT GR2 ZINC 1/4-20 X 3/4"
3	NC02-25-0007	3	WASHER ZINC 0.281 = 9/32
4	NC01-96-0009	3	NYLON-INSERT LOCKNUT ZINC 1/4-20
5	33-98-0621	1	OPERATION MANUAL TB 270

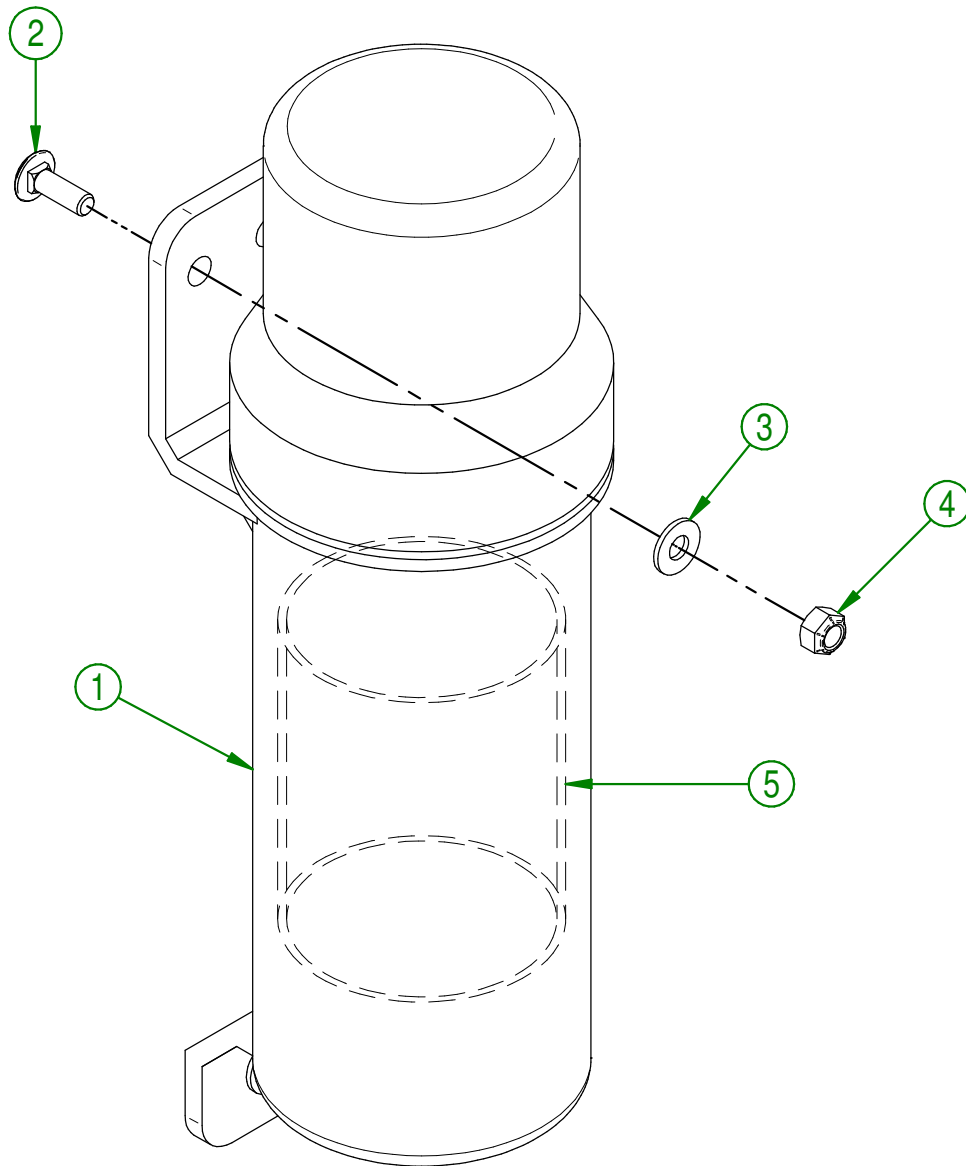

<b>AGRIMETAL</b>	
<b>OPERATOR MANUEL TUBE ASSEMBLY</b>	
CREATION : 14/02/18	ASSEMBLY : <b>33-57-2566</b>
REVISION : 05/10/18	AUTHOR : J.KABWE

#	PART #	Qty	TITLE
1	NCI3-33-0052	2	STICKER FRAME LEVEL
2	NCI3-33-0183	1	STICKER CAUTION OPERATION MANUAL
3	NCI3-33-2675	2	STICKER TO INFLATE TIRE
4	NCI3-33-0227	1	STICKER FUSE 15 AMP MAXIMUM
5	NCI3-33-0192	2	STICKER (PROJECTION RISK)
6	NCI3-33-0185	1	STICKER PICTOGRAM (FIRE + CIGARETTE)
7	NCI3-33-0035	2	STICKER AGRIMETAL
8	NCI3-33-0129	1	STICKER 101 DB
9	NCI3-33-0178	1	STICKER IMPORTANT PLEASE CHECK OIL LEVEL...
10	NCI3-33-2674	1	STICKER TO PROGRAM REMOTE CONTROL

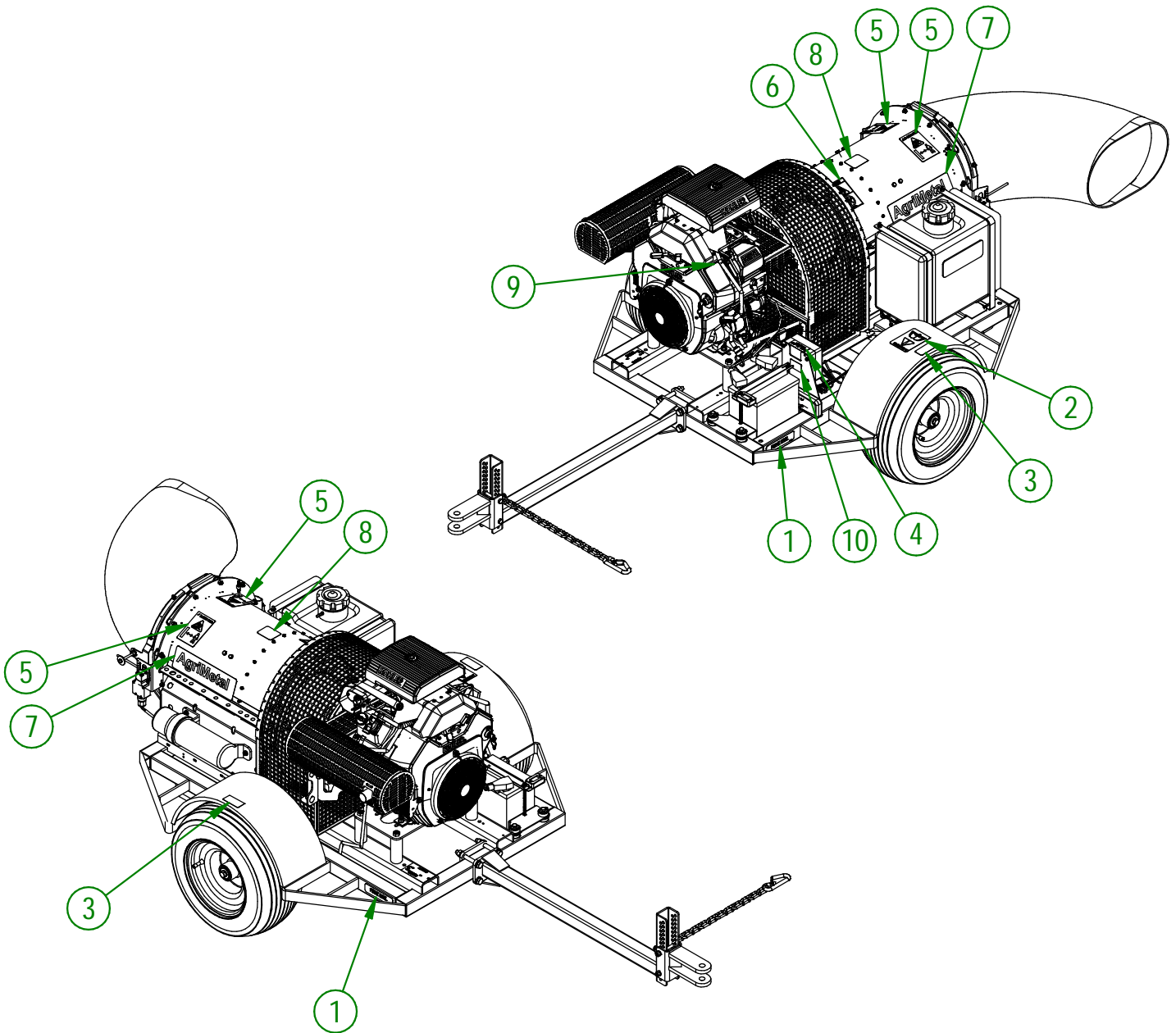
**AGRIMETAL****TURBINE BLOWER 270 IC**

CREATION : 26/02/21  
 REVISION : 31/10/23

ASSEMBLY : **33-99-2600**  
 AUTHOR : J. Houle